

**Dynamic Properties of the Negative  
Slope Algorithm Arising from  
3-Interval Exchange Transformations**

**February 2008**

**Koshiro ISHIMURA**

# Contents

<b>1</b>	<b>Introduction</b>	<b>2</b>
<b>2</b>	<b>Basic notions of the negative slope algorithm</b>	<b>6</b>
<b>3</b>	<b>Multi-dimensional maps</b>	<b>10</b>
<b>4</b>	<b>Ergodic properties of the negative slope algorithm</b>	<b>12</b>
<b>5</b>	<b>Absolutely continuous invariant measure of the negative slope algorithm</b>	<b>17</b>
<b>6</b>	<b>Characterization of periodic points of the negative slope algorithm</b>	<b>21</b>
6.1	Some properties of the negative slope algorithm . . . . .	21
6.2	The case where the negative slope algorithm stops . . . . .	25
<b>7</b>	<b>The natural extension of the negative slope algorithm and characterization of periodic points</b>	<b>27</b>
7.1	Necessary part of Theorem 7.1 . . . . .	28
7.2	Sufficient part of Theorem 7.1 . . . . .	34
<b>8</b>	<b>Definitions and basic notions of the modified negative slope algorithm</b>	<b>38</b>
<b>9</b>	<b>Some ergodic properties of the modified negative slope algorithm</b>	<b>41</b>
9.1	Some properties for $\Phi_{\Delta_k}$ . . . . .	42
9.2	Weak Bernoulli properties of the modified negative slope algorithm . . . . .	50
<b>10</b>	<b>Absolutely continuous invariant measure of the modified negative slope algorithm</b>	<b>54</b>
<b>11</b>	<b>Characterization of periodic points of the modified negative slope algorithm</b>	<b>57</b>
11.1	Necessary part of Theorem 11.1 . . . . .	57
11.2	Sufficient part of Theorem 11.1 . . . . .	61
	<b>Acknowledgement</b>	<b>63</b>
	<b>Bibliography</b>	<b>63</b>

# 1 Introduction

First we provide a brief history of the study of interval exchange transformations and its related topics. The notion of the interval exchange transformations was first introduced by Oseledets [11]. Let  $X = [0, 1)$ . For given a probability vector  $\alpha = (\alpha_1, \dots, \alpha_n)$ , we put

$$\beta_0 = 0, \quad \beta_i = \sum_{j=1}^i \alpha_j, \quad X_i = [\beta_{i-1}, \beta_i).$$

Then we see  $X = \cup_{j=1}^n X_j$ . For a permutation  $\tau$  of the integers  $1, \dots, n$ , we denote

$$\alpha^\tau = (\alpha_{\tau^{-1}(1)}, \dots, \alpha_{\tau^{-1}(n)}).$$

We put  $\beta_i^\tau$  and  $X_i^\tau$  for  $\alpha^\tau$  as the same way. Then we define a map  $\mathcal{I} : X \rightarrow X$  as follows: For each  $1 \leq i \leq n$ ,

$$\mathcal{I}x = x - \beta_{i-1} + \beta_{\tau(i)-1} \quad x \in X_i.$$

This transformation  $\mathcal{I}$  is called an  $n$ -interval exchange transformation. About this  $n$ -interval exchange transformation, Keane showed the following results in [6]:

- (1) The transformation  $\mathcal{I}$  is minimal, i.e. every orbit is dense in the unit interval, if and only if no finite union of intervals is  $\mathcal{I}$ -invariant.
- (2) If the orbits of the discontinuity points of  $\mathcal{I}$  are infinite and distinct, then  $\mathcal{I}$  is minimal. This condition is called infinite distinct orbit condition “i.d.o.c.”
- (3) If  $\tau$  does not map any segment  $\{1, 2, \dots, k\}$  to itself except for  $k = n$  and if  $\alpha_1, \dots, \alpha_{n-1}$  are rationally independent, then the condition in (2) is satisfied and  $\mathcal{I}$  is minimal. This condition is called the irrationality condition.

The theory of interval exchange transformations is related to a number of theories in dynamical systems, for example, rotations on the unit circle and billiard on polygons. From above results, it was natural to ask whether the Lebesgue measure is the unique invariant measure for any “i.d.o.c.” interval exchange transformation. However, Keynes and Newton[8] gave an example of a non-uniquely ergodic 5-interval exchange transformation which satisfies the condition in (2). Later, Keane[7] showed an example of non-uniquely ergodic 4-interval exchange transformations satisfying the irrationality condition (3). In the same paper, Keane conjectured the almost all interval exchange transformations are uniquely ergodic, which was called “Keane conjecture”. Keane’s idea for constructing a non-uniquely ergodic interval exchange transformation was that an induced transformation of an interval exchange transformation was also an interval exchange transformations. Then G.Rauzy formulated this idea as “induction method” explicitly mentioning the relation between an irrational rotation of the circle and the continued fraction algorithm. Then Masur and Veech extended

this idea and solved Keane's conjecture independently. Masur's method used a relation between interval exchange transformations and the theory of Teichmüller space, on the other hand, Veech's was more concrete.

In [6], Keane showed that all "i.d.o.c." 3-interval exchange transformations are uniquely ergodic. Then we can study the ergodic properties of 3-interval exchange transformations. Especially, we can deeply research for structure of words, for example a complexity of words, arising from 3-interval exchange transformations at the view points of languages.

The negative slope algorithm (n.s.a.) was introduced by S. Ferenczi, C. Holton, and L. Zamboni [1] to discuss the structure of some special 3-interval exchange transformations. It is a kind of multidimensional continued fractions algorithm and some arithmetic properties of the n.s.a. were discussed in [1]. They discuss a complexity of words which are natural codings of orbits of 3-interval exchange transformations in [2]. They also study spectral/ergodic properties of 3-interval exchange transformations in [3]. In the same paper, they showed that new examples of weakly mixing 3-interval exchange transformations and the existence of 3-interval exchange transformations having irrational eigenvalues and discrete spectrum.

The n.s.a. is deduced from 3-interval exchange transformations as follows (see [4] for details). First, we recall 3-interval exchange transformations. For  $0 < \alpha < 1$ ,  $0 < \beta < 1$  with  $0 < 2\alpha < 1$ ,  $\alpha + \beta < 1$ ,  $2\alpha + \beta > 1$ , we define 3-interval exchange transformation  $\mathcal{I}$  on  $[0, 1)$  by

$$\mathcal{I}x = \begin{cases} x + 1 - \alpha & \text{if } x \in [0, \alpha) \\ x + 1 - 2\alpha - \beta & \text{if } x \in [\alpha, \alpha + \beta) \\ x - \alpha - \beta & \text{if } x \in [\alpha + \beta, 1). \end{cases}$$

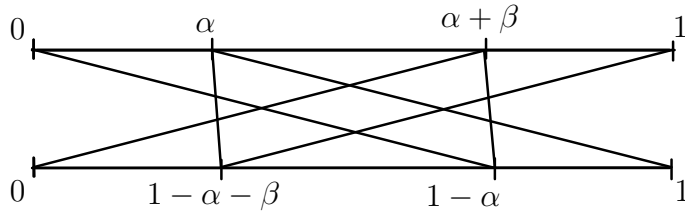

We fix  $\alpha$  and  $\beta$  and define  $E_1 = [\alpha - l_1, \alpha + r_1)$ ,  $E_2 = [\alpha + \beta - l_2, \alpha + \beta + r_2)$  for some positive real number  $l_1, r_1, l_2, r_2$  as the following figure.

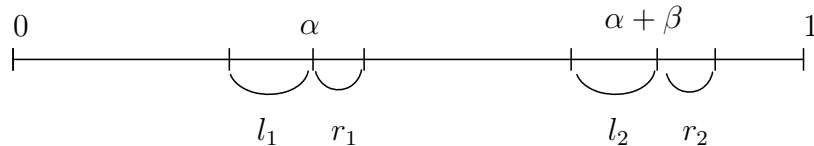

We decompose the parameter set  $\mathcal{X}_0$  of  $(l_1, r_1, l_2, r_2)$

$$\mathcal{X}_0 = I_0 \cup II_0 \cup III_0$$

with

$$\begin{aligned} I_0 &= \{l_i > 0, r_i > 0, l_i \neq r_i, i = 1, 2, r_1 = r_2\} \\ II_0 &= \{l_i > 0, r_i > 0, l_i \neq r_{3-i}, i = 1, 2, l_1 + r_1 = l_2 + r_2\} \\ III_0 &= \{l_i > 0, r_i > 0, l_i \neq r_i, i = 1, 2, l_1 = l_2\} \end{aligned}$$

Furthermore, we define  $\mathcal{R}$  on  $II_0$  by

$$\mathcal{R}(l_1, r_1, l_2, r_2) = \begin{cases} (l_1 - k_1(l_1 - r_2), (k_1 + 1)(l_2 - r_1) - l_1, l_2 - k_2(l_2 - r_1), (k_2 + 1)(l_2 - r_1) - l_2) \\ \quad \text{if } l_1 > r_2 \quad \text{where } k_i = \left\lfloor \frac{l_i}{l_i - r_{3-i}} \right\rfloor \\ ((k_1 + 1)(r_2 - l_1) - r_1, r_1 - k_1(r_1 - l_2), (k_2 + 1)(r_2 - l_1) - r_2, r_2 - k_2(r_2 - l_1)) \\ \quad \text{if } l_1 > r_2 \quad \text{where } k_i = \left\lfloor \frac{r_i}{r_i - l_{3-i}} \right\rfloor. \end{cases}$$

(Actually,  $\mathcal{R}$  is a induced transformation of a map of  $\mathcal{X}_0$ , see [4].) We define the n.s.a. as the normalized form of  $\mathcal{R}$  by normalizing by  $l_1 + l_2 + r_1 + r_2 = 2$  and taking  $(r_1, r_2)$  if  $l_1 > r_2$ ,  $(l_1, l_2)$  if  $l_1 < r_2$  as independent variables and replacing  $l$  with  $r$ . Then we see the following map, the negative slope algorithm  $T$ , on  $\mathbb{X} := [0, 1]^2 \setminus \{(x, y) \mid x + y = 1\}$ .

$$T(x, y) = \begin{cases} \left( \frac{1-y}{1-(x+y)} - \left\lfloor \frac{1-y}{1-(x+y)} \right\rfloor, \frac{1-x}{1-(x+y)} - \left\lfloor \frac{1-x}{1-(x+y)} \right\rfloor \right) & \text{if } x + y < 1 \\ \left( \frac{y}{(x+y)-1} - \left\lfloor \frac{y}{(x+y)-1} \right\rfloor, \frac{x}{(x+y)-1} - \left\lfloor \frac{x}{(x+y)-1} \right\rfloor \right) & \text{if } x + y > 1. \end{cases}$$

Let  $(x_k, y_k) = T^k(x, y)$ ,  $k \geq 0$  for  $(x, y) \in \mathbb{X}$ . Then we say that iteration by  $T$  of  $(x, y) \in \mathbb{X}$  stops if there exists  $k_0 \geq 0$  s.t.  $x_{k_0} = 0$  or  $y_{k_0} = 0$  or  $x_{k_0} + y_{k_0} = 1$ . S. Ferenczi and L. F. C. da Rocha [4] discussed ergodic properties of the n.s.a. Indeed, they showed the existence of an absolutely continuous invariant measure, which is ergodic. In this paper, we first show the following.

### Main Result I

- (a) (**Theorem 4.11**) *The n.s.a. with the absolutely continuous invariant probability measure is weak Bernoulli.*
- (b) (**Corollary 5.2**) *The absolutely continuous invariant probability measure  $\mu$  for the n.s.a. is give by  $\frac{d\mu}{d\lambda} = \frac{1}{2 \log 2} \frac{1}{x+y}$ , where  $\lambda$  is Lebesgue measure.*
- (c) (**Proposition 5.3**) *The entropy  $H_\mu(T)$  of the n.s.a. is equal to  $\frac{\pi^2}{4 \log 2}$ .*

We show that the n.s.a. satisfies conditions for a multi-dimensional map given by M. Yuri [15] to prove Theorem 4.11. We also derive the absolutely continuous invariant measure

given in [4] from a 4-dimensional representation of the natural extension of the n.s.a. in Corollary 5.2 and compute the explicit value of entropy of the n.s.a. by Rohlin's entropy formula in Proposition 5.3. We also give the exponent constant of the denominator of the  $n$ -th convergent of simultaneous approximations arising from the n.s.a. in Proposition 5.4.

Furthermore, we characterize purely periodic points of the n.s.a. by using the natural extension method. Our main result II is the following:

**Main Result II (Theorem 7.11)** *Suppose iteration by the n.s.a.  $T$  of  $(x, y) \in \mathbb{X}$  does not stop. Then the sequence  $(T^k(x, y) : k \geq 0)$  is purely periodic if and only if  $x$  and  $y$  are in the same quadratic extension of  $\mathbb{Q}$  and  $(x^*, y^*)$  is in  $(-\infty, 0)^2$  where  $x^*$  denotes the algebraic conjugate of  $x$ .*

Ferenczi and da Rocha[4] also deduce a slightly different algorithm from 3-interval exchange transformations, which we call the modified negative slope algorithm (m.n.s.a.). The m.n.s.a.  $S$  is defined on  $\mathbb{X}$  as follows:

$$S(x, y) = \begin{cases} \left( \left[ \frac{y}{(x+y)-1} \right] - \frac{y}{(x+y)-1}, \left[ \frac{x}{(x+y)-1} \right] - \frac{x}{(x+y)-1} \right) & \text{if } x + y > 1 \\ \left( \frac{1-y}{1-(x+y)} - \left\lfloor \frac{1-y}{1-(x+y)} \right\rfloor, \frac{1-x}{1-(x+y)} - \left\lfloor \frac{1-x}{1-(x+y)} \right\rfloor \right) & \text{if } x + y < 1. \end{cases}$$

We say that iteration by  $S$  of  $(x, y) \in \mathbb{X}$  stops if there exists  $k_0 \geq 0$  s.t.  $x_{k_0} = 0$  or  $y_{k_0} = 0$  or  $x_{k_0} + y_{k_0} = 1$  where  $(x_k, y_k) = S^k(x, y)$  for  $k \geq 0$ . Ferenczi and da Rocha showed that the existence of the absolutely continuous invariant measure of this algorithm and its ergodicity in [4]. We show that the m.n.s.a. has the same dynamical properties as the n.s.a. in this paper. Therefore we have the following.

### Main Result III

- (d) **Theorem 9.17** *The m.n.s.a. with the absolutely continuous invariant probability measure is weak Bernoulli.*
- (e) **Corollary 10.2** *The absolutely continuous invariant probability measure  $\eta$  for the m.n.s.a. is give by  $\frac{d\eta}{d\lambda} = \frac{1}{2 \log 2} \frac{1}{(x+y)(2-x-y)}$ , where  $\lambda$  is Lebesgue measure.*
- (f) **Proposition 10.3** *The entropy  $H_\eta(T)$  of the m.n.s.a. is equal to  $\frac{\pi^2}{8 \log 2}$ .*

We also give the exponent constant of the denominator of the  $n$ -th convergent of simultaneous approximations arising from the m.n.s.a. in Proposition 10.4. The following result shows the characterization of purely periodic points of the m.n.s.a.

**Main Result IV (Theorem 11.1)** *Suppose iteration by the m.n.s.a.  $S$  of  $(x, y) \in \mathbb{X}$  does not stop. Then the sequence  $(S^k(x, y) : k \geq 0)$  is purely periodic if and only if  $x$  and  $y$  are in the same quadratic extension of  $\mathbb{Q}$  and  $(x^*, y^*)$  is in  $(-\infty, 0)^2 \cup (1, \infty)^2$  where  $x^*$*

denotes the algebraic conjugate of  $x$ .

The construction of this thesis is as follows. In §2, we give the definition of the n.s.a. again and discuss some basic notions related to the n.s.a. Then, in §3, we explain some sufficient conditions by [15] for multi-dimensional maps  $T$  to be weak Bernoulli. In §4, we prove Theorem 4.11 by showing a number of properties which implies that Yuri's conditions in §3 holds for the n.s.a. Finally, in §5, we construct a 4-dimensional map, which is the natural extension of the n.s.a. and derive the absolutely continuous invariant measure for the n.s.a. as the marginal distribution of the invariant measure for the natural extension of the n.s.a. in Corollary 5.2. We note that the invariant measure for this representation of the natural extension of the n.s.a. is given "a priori", see Schweiger [13]. Then we calculate the entropy of the n.s.a. by Rohlin's formula in Proposition 5.3. In §6, we give a necessary condition that iteration by the n.s.a.  $T$  of  $(x, y) \in \mathbb{X}$  stops. Then in §7, we show that a necessary and sufficient condition for purely periodic points of the n.s.a. by using the natural extension of the n.s.a. as Theorem 7.11. In §8, we give the definition and basic notations of the m.n.s.a. In §9, we show that some basic properties of the m.n.s.a. and then, we prove Theorem 9.17 as in §4. In §10, we construct a 4-dimensional map, which is the natural extension of the m.n.s.a. In Corollary 10.2, we derive the absolutely continuous invariant measure for the m.n.s.a. as the marginal distribution of the invariant measure for the natural extension of the m.n.s.a. Then we calculate the entropy of the m.n.s.a. by Rohlin's formula in Proposition 10.3. Finally, in §11, we characterize purely periodic points of the m.n.s.a. by using the natural extension of the m.n.s.a. as Theorem 11.1 by the same way in §7.

## 2 Basic notions of the negative slope algorithm

First we define a map  $T$  on the unit square, which is called the negative slope algorithm. For  $(x, y) \in \mathbb{X} = [0, 1]^2 \setminus \{(x, y) \mid x + y = 1\}$ , we define

$$T(x, y) = \begin{cases} \left( \frac{y}{(x+y)-1} - \left[ \frac{y}{(x+y)-1} \right], \frac{x}{(x+y)-1} - \left[ \frac{x}{(x+y)-1} \right] \right) & \text{if } x + y > 1 \\ \left( \frac{1-y}{1-(x+y)} - \left[ \frac{1-y}{1-(x+y)} \right], \frac{1-x}{1-(x+y)} - \left[ \frac{1-x}{1-(x+y)} \right] \right) & \text{if } x + y < 1. \end{cases}$$

We put

$$n(x, y) = \begin{cases} \left[ \frac{y}{(x+y)-1} \right] & \text{if } x + y > 1 \\ \left[ \frac{1-y}{1-(x+y)} \right] & \text{if } x + y < 1, \end{cases}$$

$$m(x, y) = \begin{cases} \left\lfloor \frac{x}{(x+y)-1} \right\rfloor & \text{if } x + y > 1 \\ \left\lfloor \frac{1-x}{1-(x+y)} \right\rfloor & \text{if } x + y < 1, \end{cases}$$

and

$$\varepsilon(x, y) = \begin{cases} -1 & \text{if } x + y > 1 \\ +1 & \text{if } x + y < 1. \end{cases}$$

Then we put

$$\begin{cases} n_k(x, y) & = n(T^{k-1}(x, y)) \\ m_k(x, y) & = m(T^{k-1}(x, y)) \\ \varepsilon_k(x, y) & = \varepsilon(T^{k-1}(x, y)) \end{cases}$$

for  $k \geq 1$ . Then we note that  $n_k, m_k \geq 1$  for  $k \geq 1$  and for any sequence  $((\varepsilon_i, n_i, m_i), i \geq 1)$ , there exists  $(x, y) \in \mathbb{X}$  such that  $(\varepsilon_i(x, y), n_i(x, y), m_i(x, y)) = (\varepsilon_i, n_i, m_i)$  unless there exists  $k \geq 1$  such that  $(\varepsilon_i, m_i) = (+1, 1)$  for  $i \geq k$  or  $(\varepsilon_i, n_i) = (+1, 1)$  for  $i \geq k$ . We show these properties later as Lemma 6.7. By [1] and [?] we see that if  $(x, y) \neq (x', y') \in \mathbb{X}$ , then there exists  $k \geq 1$  such that

$$(\varepsilon_k(x, y), n_k(x, y), m_k(x, y)) \neq (\varepsilon_k(x', y'), n_k(x', y'), m_k(x', y')).$$

Now we introduce the projective representation of  $T$ . We put

$$A_{(+1, n, m)} = \begin{pmatrix} n & n-1 & 1-n \\ m-1 & m & 1-m \\ -1 & -1 & 1 \end{pmatrix}$$

and

$$A_{(-1, n, m)} = \begin{pmatrix} -n & -n+1 & n \\ -m+1 & -m & m \\ 1 & 1 & -1 \end{pmatrix}$$

for  $m, n \geq 1$ . Then we see

$$A_{(+1, n, m)}^{-1} = \begin{pmatrix} 1 & 0 & n-1 \\ 0 & 1 & m-1 \\ 1 & 1 & n+m-1 \end{pmatrix}.$$

and

$$A_{(-1, n, m)}^{-1} = \begin{pmatrix} 0 & 1 & m \\ 1 & 0 & n \\ 1 & 1 & n+m-1 \end{pmatrix}$$

We identify  $(x, y)$  to  $\begin{pmatrix} \alpha x \\ \alpha y \\ \alpha \end{pmatrix}$  for  $\alpha \neq 0$ . Then  $T(x, y)$  is identified to

$$A_{(\varepsilon_1(x, y), n_1(x, y), m_1(x, y))} \begin{pmatrix} x \\ y \\ 1 \end{pmatrix}$$



and its local inverse is given by

$$A_{(\varepsilon_1(x,y), n_1(x,y), m_1(x,y))}^{-1}.$$

In this way, we get a representation of  $(x, y)$  by

$$A_{(\varepsilon_1, n_1, m_1)}^{-1} A_{(\varepsilon_2, n_2, m_2)}^{-1} A_{(\varepsilon_3, n_3, m_3)}^{-1} \cdots$$

and  $T$  is defined as a multiplication by  $A_{(\varepsilon_1, n_1, m_1)}$  from the left and acts as a shift on the set of infinite sequence of matrices

$$\left\{ A_{(\varepsilon_1, n_1, m_1)}^{-1} A_{(\varepsilon_2, n_2, m_2)}^{-1} A_{(\varepsilon_3, n_3, m_3)}^{-1} \cdots \mid \varepsilon_k = \pm 1, n_k, m_k \geq 1 \text{ for } k \geq 1 \right\}.$$

For a given sequence  $((\varepsilon_1, n_1, m_1), (\varepsilon_2, n_2, m_2), \dots, (\varepsilon_k, n_k, m_k))$ , we define a cylinder set of length  $k$  by

$$\begin{aligned} & \langle (\varepsilon_1, n_1, m_1), (\varepsilon_2, n_2, m_2), \dots, (\varepsilon_k, n_k, m_k) \rangle \\ &= \{(x, y) \mid (\varepsilon_i(x, y), n_i(x, y), m_i(x, y)) = (\varepsilon_i, n_i, m_i), 1 \leq i \leq k\}. \end{aligned}$$

For  $(x, y) \in \langle (\varepsilon_1, n_1, m_1), (\varepsilon_2, n_2, m_2), \dots, (\varepsilon_k, n_k, m_k) \rangle$ ,  $T^k(x, y)$  is expressed as

$$A_{(\varepsilon_k, n_k, m_k)} \cdots A_{(\varepsilon_1, n_1, m_1)} \begin{pmatrix} x \\ y \\ 1 \end{pmatrix}$$

and its local inverse  $\Psi_{\langle (\varepsilon_1, n_1, m_1), (\varepsilon_2, n_2, m_2), \dots, (\varepsilon_k, n_k, m_k) \rangle}$  is expressed as

$$A_{(\varepsilon_1, n_1, m_1)}^{-1} \cdots A_{(\varepsilon_k, n_k, m_k)}^{-1}.$$

Since

$$\begin{aligned} & \left\{ \left( \frac{y}{(x+y)-1}, \frac{x}{(x+y)-1} \right) : (x, y) \in \mathbb{X}, x+y > 1 \right\} \\ &= \left\{ \left( \frac{1-y}{1-(x+y)}, \frac{1-x}{1-(x+y)} \right) : (x, y) \in \mathbb{X}, x+y < 1 \right\} \\ &= \{(\alpha, \beta) : \alpha \geq 1, \beta \geq 1\}, \end{aligned}$$

we see that for any  $\{(\varepsilon_k, n_k, m_k), 1 \leq k \leq l\}$ ,  $\varepsilon_k = +1$  or  $-1$ ,  $n_k, m_k \geq 1$ , we have

$$T^l \{(x, y) \in \mathbb{X} : \varepsilon_k(x, y) = \varepsilon_k, n_k(x, y) = n_k, m_k(x, y) = m_k, 1 \leq k \leq l\} = \mathbb{X} \quad \text{a.e.} \quad (2.1)$$

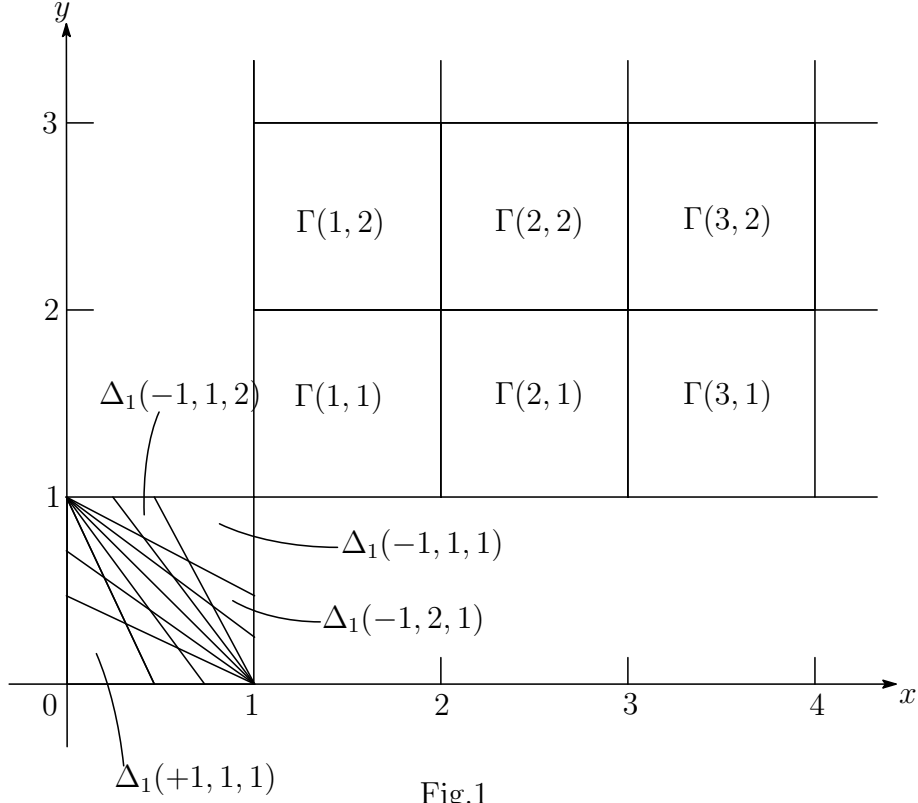

Fig.1

Let us introduce a map  $f : \mathbb{X}^2 \rightarrow \mathbb{R}^2$  by

$$f(x, y) = \begin{cases} \left( \frac{y}{(x+y)-1}, \frac{x}{(x+y)-1} \right) & \text{if } x + y > 1 \\ \left( \frac{1-y}{1-(x+y)}, \frac{1-x}{1-(x+y)} \right) & \text{if } x + y < 1. \end{cases}$$

(see Fig.1) Then we see the following properties.

- (i)  $f(0, 0) = (0, 0)$   
 $f(1, 1) = (0, 0)$
- (ii)  $f(\Delta(\pm 1, n, m)) = \Gamma(n, m)$
- (iii)  $T(x, y) = f(x, y) - (n, m)$

where  $(n, m) \in \mathbb{N}^2$  is given by

$$(n, m) = \begin{cases} \left( \left[ \frac{y}{(x+y)-1} \right], \left[ \frac{x}{(x+y)-1} \right] \right) & \text{if } x + y > 1 \\ \left( \left[ \frac{1-y}{1-(x+y)} \right], \left[ \frac{1-x}{1-(x+y)} \right] \right) & \text{if } x + y < 1. \end{cases}$$

### 3 Multi-dimensional maps

In this section, we summarize results of [15], which we shall use in the following section.

We consider a map  $T$  of a bounded domain  $\mathbb{X}$  of  $\mathbb{R}^d$  onto itself with its countable partition  $Q = \{X_a : a \in I\}$ . We assume the following :

- (i) Each  $X_a$  is a measurable and connected subset of  $\mathbb{X}$  with piecewise smooth boundary.
- (ii) There exists a finite number of subsets of  $\mathbb{X}$ ,  $U_0 (= \mathbb{X}), U_1, \dots, U_N$  such that  $U_j, 1 \leq j \leq N$  are sets of positive measure and for any  $a_1, \dots, a_n \in I$

$$T^n(X_{a_1} \cap T^{-1}X_{a_2} \cap \dots \cap T^{-(n-1)}X_{a_n}) = U_j \quad \text{a.e.}$$

for some  $j, 0 \leq j \leq N$  whenever  $X_{a_1} \cap T^{-1}X_{a_2} \cap \dots \cap T^{-(n-1)}X_{a_n}$  is a set of positive Lebesgue measure.

- (iii) For any  $a \in I$ ,  $T|_{X_a}$ , the restriction of  $T$  to  $X_a$ , is injective and  $C^1$ .

We write

$$\langle a_1, \dots, a_n \rangle = X_{a_1} \cap T^{-1}X_{a_2} \cap \dots \cap T^{-(n-1)}X_{a_n}$$

which we call a cylinder set (of length  $n$ ). We only consider cylinder sets of positive Lebesgue measure. From (iii), the restriction of  $T$  to  $\langle a_1, \dots, a_n \rangle$  is injective, we can define  $(T|_{\langle a_1, \dots, a_n \rangle})^{-1}$  of  $U_j$  for some  $j, 0 \leq j \leq N$ , onto  $\langle a_1, \dots, a_n \rangle$ , which we denote by  $\Psi_{\langle a_1, \dots, a_n \rangle}$ . We fix a constant  $C \geq 1$  and define the set of ‘‘Rényi cylinders’’ by

$$\begin{aligned} R(T) = \{ \langle a_1, \dots, a_n \rangle : & \sup_{x \in T^n \langle a_1, \dots, a_n \rangle} |\det D\Psi_{\langle a_1, \dots, a_n \rangle}(x)| \\ & \leq C \cdot \inf_{x \in T^n \langle a_1, \dots, a_n \rangle} |\det D\Psi_{\langle a_1, \dots, a_n \rangle}(x)|, n \geq 1 \}. \end{aligned}$$

Moreover we put

$$\mathcal{D}_n = \{ \langle a_1, \dots, a_n \rangle : \langle a_1, \dots, a_j \rangle \notin R(T) \text{ for } 1 \leq j \leq n \},$$

$$\mathbf{D}_n = \bigcup_{\langle a_1, \dots, a_n \rangle \in \mathcal{D}_n} \langle a_1, \dots, a_n \rangle,$$

$$\mathcal{B}_n = \{ \langle a_1, \dots, a_n \rangle \in R(T) : \langle a_1, \dots, a_{n-1} \rangle \in \mathcal{D}_{n-1} \},$$

and

$$\mathbf{B}_n = \bigcup_{\langle a_1, \dots, a_n \rangle \in \mathcal{B}_n} \langle a_1, \dots, a_n \rangle.$$

Then we consider the following conditions :

- (C.1)  $(T, Q)$  separates points, that is, for any  $x, x' \in \mathbb{X}$  there exists  $n \geq 0$  such that  $T^n(x)$  and  $T^n(x')$  are not the same elements in  $Q$ .

(C.2) For each  $j$ ,  $0 \leq j \leq N$ , there exists  $\langle a_1, \dots, a_{s_j} \rangle \subset U_j$  such that  $\langle a_1, \dots, a_{s_j} \rangle \in R(T)$  and  $T^{s_j} \langle a_1, \dots, a_{s_j} \rangle = \mathbb{X}$ .

(C.3) If  $\langle a_1, \dots, a_n \rangle \in R(T)$ , then  $\langle b_1, \dots, b_m, a_1, \dots, a_n \rangle \in R(T)$  unless  $\langle b_1, \dots, b_m, a_1, \dots, a_n \rangle$  is a set of Lebesgue measure 0.

(C.4)

$$\sum_{n=1}^{\infty} \lambda(\mathbf{D}_n) < \infty$$

where  $\lambda$  denotes  $d$ -dimensional Lebesgue measure.

$$(C.4)^* \sum_{n=1}^{\infty} \lambda(\mathbf{D}_n) \cdot \log n < \infty.$$

(C.5) For any  $n \geq 1$ ,

$$\sum_{m=0}^{\infty} \left( \sum_{\langle k_1, \dots, k_m \rangle} \left( \sup_{y \in T^m \langle k_1, \dots, k_m \rangle \cap (\cup_{j=1}^n \mathbf{B}_j)} |\det D\Psi_{\langle k_1, \dots, k_m \rangle}(y)| \right) \right) < +\infty.$$

$$(C.6) \quad \#\mathcal{D}_1 < \infty.$$

(C.7) There exists a positive integer  $l$  such that for all  $n > 0$  and all  $\langle a_1, \dots, a_n \rangle \in \mathcal{D}_n$ ,

$$\frac{\sup_{x \in T^n \langle a_1, \dots, a_n \rangle} |\det D\Psi_{\langle a_1, \dots, a_n \rangle}(x)|}{\inf_{x \in T^n \langle a_1, \dots, a_n \rangle} |\det D\Psi_{\langle a_1, \dots, a_n \rangle}(x)|} = O(n^l).$$

(C.8)  $\log |\det DT(\cdot)|$  is Lebesgue integrable.

(C.9) there exists a positive integer  $k_0$  such that if  $\langle a_1, \dots, a_n \rangle \in \mathcal{D}_n^c$  and  $\langle a_2, \dots, a_n \rangle \in \mathcal{D}_{n-1}$ , then

$$\langle a_1, \dots, a_n \rangle \subset \bigcup_{j=1}^{k_0} \mathbf{B}_j.$$

Then we have the following.

**Theorem 3.1** ([15])

(i) (C.1) – (C.4) imply that there exists an absolutely continuous invariant probability measure  $\mu$  and  $(T, \mu)$  is exact, i.e.

$$\bigcap_{k=1}^{\infty} T^{-k} \mathbb{B}$$

is trivial, where  $\mathbb{B}$  denotes the set of Borel subsets of  $\mathbb{X}$ .

(ii) (C.1) – (C.8) imply Rohlin's entropy formula :

$$h(T) = \int_{\mathbb{X}} \log |\det DT(x)| d\mu(x).$$

(iii) (C.1) – (C.9) with (C.4)\* imply that  $(T, \mu, Q)$  is weak Bernoulli, that is, for any  $\varepsilon > 0$ , there exists  $n_0 > 0$  such that  $\{\Delta_k\}$  and  $\{\Delta_l\}$  are  $\varepsilon$ -independent for any  $k \geq 1, l \geq k+n$ , and  $n \geq n_0$ , where  $\{\Delta_k\}$  and  $\{\Delta_l\}$  denote the sets of cylinder sets of length  $k$  and  $l$  respectively and Two partitions  $\mathcal{F}_1$  and  $\mathcal{F}_2$  are said to be  $\varepsilon$ -independent if

$$\sum_{A \in \mathcal{F}_1} \sum_{B \in \mathcal{F}_2} |\mu(A \cap B) - \mu(A)\mu(B)| < \varepsilon.$$

## 4 Ergodic properties of the negative slope algorithm

First of all, from (2.1), we can take  $\{U_0\}$  as  $\{U_0, \dots, U_N\}$  in the previous section ( $U_0 = \mathbb{X}$ ). We show the following.

**Theorem 4.1.** *There exists an absolutely continuous invariant probability measure  $\mu$  for  $T$  and  $(T, \mu)$  is exact.*

**REMARK 4.2.** [4] discussed the explicit form of the density function  $\frac{d\mu}{d\lambda}$ , which we will see later, and showed its ergodicity. The exactness implies not only ergodicity but also mixing of all degrees.

To prove this theorem, we will show that  $T$  satisfies the conditions (C.1) - (C.4). We define the set  $R(T)$  by

$$R(T) = \{((\varepsilon_1, n_1, m_1), (\varepsilon_2, n_2, m_2), \dots, (\varepsilon_k, n_k, m_k)) \mid (\varepsilon_k, n_k, m_k) \neq (+1, 1, 1)\}.$$

In the sequel, we simply write  $\Delta_k$  for a cylinder set

$$\langle (\varepsilon_1, n_1, m_1), (\varepsilon_2, n_2, m_2), \dots, (\varepsilon_k, n_k, m_k) \rangle$$

if it is clear in the context. We put

$$A_{(\varepsilon_1, n_1, m_1)}^{-1} \cdots A_{(\varepsilon_k, n_k, m_k)}^{-1} = \begin{pmatrix} p_1^{(k)} & p_2^{(k)} & p_3^{(k)} \\ r_1^{(k)} & r_2^{(k)} & r_3^{(k)} \\ q_1^{(k)} & q_2^{(k)} & q_3^{(k)} \end{pmatrix}$$

for any sequence  $((\varepsilon_1, n_1, m_1), (\varepsilon_2, n_2, m_2), \dots, (\varepsilon_k, n_k, m_k)), k \geq 1$ . Then it is easy to see that  $q_1^{(k)} = q_2^{(k)}$ .

**Lemma 4.3.** For any sequence  $((\varepsilon_1, n_1, m_1), (\varepsilon_2, n_2, m_2), \dots, (\varepsilon_k, n_k, m_k))$ ,  $\varepsilon_i = \pm 1, n_i, m_i \geq 1, 1 \leq i \leq k$ , we see

- (i)  $T^k(\Delta_k) = \mathbb{X}$ ,
- (ii)

$$|\det D\Psi_{\Delta_k}(x, y)| = \frac{1}{(q_1^{(k)}x + q_2^{(k)}y + q_3^{(k)})^3}.$$

Proof. It is an easy consequence of induction and calculation, respectively, see also F. Schweiger [13], proposition 2 for (ii).

From this lemma, it is easy to see the following.

**Lemma 4.4.** If  $\langle (\varepsilon_1, n_1, m_1), (\varepsilon_2, n_2, m_2), \dots, (\varepsilon_k, n_k, m_k) \rangle \in R(T)$ , then

$$\sup_{(x,y) \in \mathbb{X}} |\det D\Psi_{\Delta_k}(x, y)| \leq 3^3 \inf_{(x,y) \in \mathbb{X}} |\det D\Psi_{\Delta_k}(x, y)|.$$

Therefore,  $R(T)$  is the set of Rényi cylinders.

Proof. Since

$$A_{(\varepsilon_1, n_1, m_1)}^{-1} \cdots A_{(\varepsilon_k, n_k, m_k)}^{-1} = \begin{cases} \begin{pmatrix} p_1^{(k-1)} & p_2^{(k-1)} & p_3^{(k-1)} \\ r_1^{(k-1)} & r_2^{(k-1)} & r_3^{(k-1)} \\ q_1^{(k-1)} & q_2^{(k-1)} & q_3^{(k-1)} \end{pmatrix} \begin{pmatrix} 1 & 0 & n_k - 1 \\ 0 & 1 & m_k - 1 \\ 1 & 1 & n_k + m_k - 1 \end{pmatrix} \\ \text{if } \varepsilon_k = +1 \\ \begin{pmatrix} p_1^{(k-1)} & p_2^{(k-1)} & p_3^{(k-1)} \\ r_1^{(k-1)} & r_2^{(k-1)} & r_3^{(k-1)} \\ q_1^{(k-1)} & q_2^{(k-1)} & q_3^{(k-1)} \end{pmatrix} \begin{pmatrix} 0 & 1 & m_k \\ 1 & 0 & n_k \\ 1 & 1 & n_k + m_k - 1 \end{pmatrix} \\ \text{if } \varepsilon_k = -1 \end{cases},$$

we see that

$$(q_1^{(k)}, q_2^{(k)}, q_3^{(k)}) = \begin{cases} \left( q_1^{(k-1)} + q_3^{(k-1)}, q_2^{(k-1)} + q_3^{(k-1)}, (n_k - 1)q_1^{(k-1)} + (m_k - 1)q_2^{(k-1)} + (n_k + m_k - 1)q_3^{(k-1)} \right) \\ \text{if } \varepsilon_k = +1 \\ \left( q_2^{(k-1)} + q_3^{(k-1)}, q_1^{(k-1)} + q_3^{(k-1)}, m_k q_1^{(k-1)} + n_k q_2^{(k-1)} + (n_k + m_k - 1)q_3^{(k-1)} \right) \\ \text{if } \varepsilon_k = -1. \end{cases}$$

It follows by induction that  $q_1^{(k)} = q_2^{(k)}$  for any  $k \geq 1$ . If  $\Delta_k \in R(T)$ , then  $n_k + m_k \geq 3$  or  $n_k + m_k \geq 2$  when  $\varepsilon_k = -1$  or  $+1$ , respectively. Thus we see  $q_i^{(k)} < q_3^{(k)}$ ,  $i = 1, 2$ , whenever  $\Delta_k \in R(T)$ . By Lemma 4.3, we have

$$\frac{1}{(q_1^{(k)} + q_2^{(k)} + q_3^{(k)})^3} \leq |\det D\Psi_{\Delta_k}(x, y)| \leq \frac{1}{(q_3^{(k)})^3}.$$

Hence we get

$$\frac{1}{(3q_3^{(k)})^3} \leq |\det D\Psi_{\Delta_k}(x, y)| \leq \frac{1}{(q_3^{(k)})^3},$$

which implies the assertion of this lemma.

Let's define the following:

$$\mathcal{D}_k = \{ \langle (\varepsilon_1, n_1, m_1), (\varepsilon_2, n_2, m_2), \dots, (\varepsilon_k, n_k, m_k) \rangle \mid \langle (\varepsilon_1, n_1, m_1), (\varepsilon_2, n_2, m_2), \dots, (\varepsilon_i, n_i, m_i) \rangle \notin R(T) \text{ for } 1 \leq i \leq k \},$$

$$\mathbf{D}_k = \bigcup_{\Delta_k \in \mathcal{D}_k} \Delta_k,$$

$$\mathcal{B}_k = \{ \langle (\varepsilon_1, n_1, m_1), (\varepsilon_2, n_2, m_2), \dots, (\varepsilon_k, n_k, m_k) \rangle \in R(T) \mid \langle (\varepsilon_1, n_1, m_1), (\varepsilon_2, n_2, m_2), \dots, (\varepsilon_{k-1}, n_{k-1}, m_{k-1}) \rangle \in \mathcal{D}_{k-1} \},$$

and

$$\mathbf{B}_k = \bigcup_{\Delta_k \in \mathcal{B}_k} \Delta_k.$$

It is easy to see that

$$\mathcal{D}_k = \{ \underbrace{\langle (+1, 1, 1), \dots, (+1, 1, 1) \rangle}_{k \text{ times}} \}.$$

Now we will check the conditions of [15]. First of all, it is clear that the set of cylinder sets separates points, see (1). Lemma 4.3 (i) and Lemma 4.4 imply (C.2) and (C.3), respectively. We see the following.

**Lemma 4.5.** (C.4) *We have*

$$\sum_{k=1}^{\infty} \lambda(\mathbf{D}_k) < \infty$$

where  $\lambda$  denotes the 2-dimensional Lebesgue measure.

*Proof.* From the definition of  $T$  and simple calculation, we see that

$$\langle (+1, 1, 1) \rangle = \{ (x, y) \mid 0 \leq y < 1 - 2x, 0 \leq y < \frac{1}{2} - \frac{1}{2}x \}$$

and, in general,

$$\begin{aligned} & \underbrace{\langle (+1, 1, 1), \dots, (+1, 1, 1) \rangle}_{k \text{ times}} \\ &= \{ (x, y) \mid 0 \leq y < \frac{1}{k} - \frac{k+1}{k}x, 0 \leq y < \frac{1}{k+1} - \frac{k}{k+1}x \}. \end{aligned}$$

Hence we have

$$\lambda(\mathbf{D}_k) = \frac{1}{(k+1)(2k+1)}$$

and get the conclusion of this lemma.

This completes the proof of Theorem 4.1 by [15].

Next we show the following.

**Theorem 4.6.** (*Rohlin's formula*) *The entropy  $H_\mu(T)$  of  $(\mathbb{X}, T, \mu)$  is given by*

$$H_\mu(T) = \int_{\mathbb{X}} \log |\det DT| d\mu$$

In the following, we show (C.5)–(C.8) in [15], which imply this theorem.

**Lemma 4.7.** (C.5)

$$W_k = \sum_{l=0}^{\infty} \sum_{\Delta_l \in \mathcal{D}_l} \left( \sup_{(x,y) \in (\cup_{j=1}^k \mathbf{B}_j)} |\det D\Psi_{\Delta_l}(x,y)| \right) < \infty.$$

*Proof.* Since  $\Delta_l \in \mathcal{D}_l$  means

$$\Delta_l = \langle \underbrace{(+1, 1, 1), \dots, (+1, 1, 1)}_{l \text{ times}} \rangle,$$

$\Psi_{\Delta_l}$  is associated to

$$\Psi_{\Delta_l} = \underbrace{\begin{pmatrix} 1 & 0 & 0 \\ 0 & 1 & 0 \\ 1 & 1 & 1 \end{pmatrix} \cdots \begin{pmatrix} 1 & 0 & 0 \\ 0 & 1 & 0 \\ 1 & 1 & 1 \end{pmatrix}}_{l \text{ times}} = \begin{pmatrix} 1 & 0 & 0 \\ 0 & 1 & 0 \\ l & l & 1 \end{pmatrix}.$$

Thus we see

$$\det D\Psi_{\Delta_l}(x,y) = \frac{1}{(lx + ly + 1)^3}. \quad (4.1)$$

On the other hand,

$$\bigcup_{j=1}^k \mathbf{B}_j = \mathbb{X} \setminus \Delta_k$$

and

$$\min_{(x,y) \in \cup_{j=1}^k \mathbf{B}_j} x + y = \frac{1}{k+1},$$



see the proof of Lemma 4.5. Hence we get

$$\begin{aligned} \sup_{(x,y) \in (\cup_{j=1}^k \mathbf{B}_j)} |\det D\Psi_{\Delta_l}(x,y)| &= \frac{1}{(\frac{1}{k+1}l + 1)^3} \\ &\leq (k+1)^3 \frac{1}{l^3}, \end{aligned}$$

which implies the assertion of this lemma.

**Lemma 4.8.** (C.6)

$$\#\mathcal{D}_1 = 1.$$

Proof. This is obvious.

**Lemma 4.9.** (C.7) *We have*

$$\frac{\sup_{(x,y) \in \mathbb{X}} |\det D\Psi_{\Delta_k}(x,y)|}{\inf_{(x,y) \in \mathbb{X}} |\det D\Psi_{\Delta_k}(x,y)|} = \mathcal{O}(k^3)$$

for  $\Delta_k = \underbrace{\langle (+1, 1, 1), \dots, (+1, 1, 1) \rangle}_{k \text{ times}}.$

Proof. This follows from (4.1).

**Lemma 4.10.** (C.8) *The function  $\log |\det DT|$  is integrable with respect to  $\lambda$ .*

Proof.

$$\begin{aligned} &\int_{\mathbb{X}} \log |\det DT| d\lambda \\ &= - \int \int_{\mathbb{X} \cap \{x+y>1\}} 3 \log((x+y) - 1) dx dy - \int \int_{\mathbb{X} \cap \{x+y<1\}} 3 \log(1 - (x+y)) dx dy. \end{aligned}$$

Then, there exists  $K > 0$  s.t.

$$\int_{\mathbb{X}} \log |\det DT| d\lambda < K \int_0^2 \log r dr < \infty.$$

This completes the proof of the Theorem 4.6.

Finally, we show the following.

**Theorem 4.11.** *The negative slope algorithm with the absolutely continuous invariant probability measure  $\mu$  is weak Bernoulli.*

To prove this theorem we need the following two lemmas.

**Lemma 4.12.** (C.4)\*

$$\sum_{k=1}^{\infty} \lambda(\mathbf{D}_k) \cdot \log k < \infty.$$

Proof. This is clear since  $\lambda(\mathbf{D}_k) = \frac{1}{(k+1)(2k+1)}$ , see the proof of Lemma 4.5.

**Lemma 4.13.** (C.9) *If  $\langle (\varepsilon_1, n_1, m_1), (\varepsilon_2, n_2, m_2), \dots, (\varepsilon_k, n_k, m_k) \rangle \in \mathcal{D}_k^c$  and  $\langle (\varepsilon_2, n_2, m_2), \dots, (\varepsilon_k, n_k, m_k) \rangle \in \mathcal{D}_{k-1}$ , then we have  $\langle (\varepsilon_1, n_1, m_1) \rangle \in \mathbf{B}_1$ , that is,  $(\varepsilon_1, n_1, m_1) \neq (+1, 1, 1)$ .*

Proof. This is an easy consequence of the definitions of  $\mathcal{D}_k$  and  $\mathcal{B}_k$ .

Since  $T$  satisfies (C.1)–(C.9) with (C.4)\*, we can conclude the assertion of Theorem 4.11.

## 5 Absolutely continuous invariant measure of the negative slope algorithm

In [4], it was shown that the density function of the absolutely continuous invariant probability measure was given by

$$\frac{d\mu}{d\lambda} = \frac{1}{2 \log 2} \frac{1}{x+y}.$$

This was checked by Kuzmin’s equation

$$f(x, y) = \sum_{\varepsilon=\pm 1, n, m \geq 1} f(\Psi_{(\varepsilon, n, m)}(x, y)) |\det \Psi_{(\varepsilon, n, m)}(x, y)|$$

for  $f(x, y) = \frac{1}{x+y}$ .

In the sequel, we prove the same result by a different way, which is called a “natural extension method” originally started by [10] for a class of continued fraction transformations.

We start with a 4-dimensional area. Let  $\bar{\mathbb{X}} = \mathbb{X} \times (-\infty, 0)^2$ . For  $(x, y, z, w) \in \bar{\mathbb{X}}$ , we define a map  $\bar{T}$  on  $\bar{\mathbb{X}}$  by

$$\bar{T}(x, y, z, w) = \begin{cases} \left( \frac{y}{(x+y)-1} - n(x, y), \frac{x}{(x+y)-1} - m(x, y), \frac{w}{(z+w)-1} - n(x, y), \frac{z}{(z+w)-1} - m(x, y) \right) & \text{if } x + y > 1 \\ \left( \frac{1-y}{1-(x+y)} - n(x, y), \frac{1-x}{1-(x+y)} - m(x, y), \frac{1-w}{1-(z+w)} - n(x, y), \frac{1-z}{1-(z+w)} - m(x, y) \right) & \text{if } x + y < 1. \end{cases}$$

Then it is easy to see that  $\bar{T}$  is bijective on  $\bar{\mathbb{X}}$  except for the set of (4-dimensional) Lebesgue measure 0.

**Proposition 5.1.** *The measure  $\bar{\mu}$  defined by*

$$\frac{d\bar{\mu}}{d\bar{\lambda}} = \frac{1}{\{(x+y) - (z+w)\}^3}$$

*is an invariant measure for  $\bar{T}$ , where  $\bar{\lambda}$  denotes the 4-dimensional Lebesgue measure.*

*Proof.* We put

$$h(x, y, z, w) = \frac{1}{\{(x+y) - (z+w)\}^3}.$$

It is enough to show that

$$h(\bar{T}(x, y, z, w)) \cdot |\det D(\bar{T}(x, y, z, w))| \cdot h^{-1}(x, y, z, w) = 1,$$

which follows easily by simple calculation.

(case i :  $x + y > 1$ )

$$\begin{aligned} & h(\bar{T}(x, y, z, w)) \cdot |\det D(\bar{T}(x, y, z, w))| \cdot h^{-1}(x, y, z, w) \\ &= \frac{1}{\left(\frac{y+x}{(x+y)-1} - \frac{w+z}{(z+w)-1}\right)^3} \cdot \left| \frac{1}{(x+y-1)^3(z+w-1)^3} \right| \cdot \left( \frac{1}{((x+y) - (z+w))^3} \right)^{-1} \\ &= 1. \end{aligned} \tag{5.1}$$

(case ii :  $x + y < 1$ )

$$\begin{aligned} & h(\bar{T}(x, y, z, w)) \cdot |\det D(\bar{T}(x, y, z, w))| \cdot h^{-1}(x, y, z, w) \\ &= \frac{1}{\left(\frac{(1-y)+(1-x)}{1-(x+y)} - \frac{(1-w)+(1-z)}{1-(z+w)}\right)^3} \cdot \left| \frac{1}{(1-(x+y))^3(1-(z+w))^3} \right| \\ & \quad \cdot \left( \frac{1}{((1-(x+y)) - (1-(z+w)))^3} \right)^{-1} \\ &= 1. \end{aligned} \tag{5.2}$$

(5.1) and (5.2) imply the assertion of this proposition.

**Corollary 5.2.** *The measure  $\mu$  defined by*

$$\frac{d\mu}{d\lambda} = \frac{1}{2 \log 2} \frac{1}{(x+y)}$$

*is an invariant probability measure for  $T$ .*

*Proof.* It is easy to see that the projection of  $\bar{\mu}$  to  $\mathbb{X}$  is an invariant measure for  $T$ . We have

$$\int_{(-\infty,0) \times (-\infty,0)} \frac{1}{\{(x+y) - (z+w)\}^3} dzdw = \frac{1}{2} \frac{1}{(x+y)},$$

which is the assertion of this corollary.

From this formula, we can compute the entropy  $H_\mu(T)$  from Theorem 4.6.

**Proposition 5.3.**

$$H_\mu(T) = \frac{\pi^2}{4 \log 2}.$$

*Proof.* From Theorem 4.6, we have

$$\begin{aligned} H_\mu(T) &= -\frac{3}{2 \log 2} \int \int_{\{x+y>1\}} \frac{1}{x+y} \log((x+y) - 1) dx dy \\ &\quad -\frac{3}{2 \log 2} \int \int_{\{x+y<1\}} \frac{1}{x+y} \log(1 - (x+y)) dx dy. \end{aligned}$$

The right side is equal to

$$\begin{aligned} &-\frac{3}{2 \log 2} \left[ \int_1^2 \frac{2-t}{t} \log(t-1) dt + \int_0^1 \log(1-t) dt \right] \\ &= -\frac{3}{\log 2} \left[ \int_0^1 \frac{1}{1+t} \log t dt \right] \\ &= \frac{\pi^2}{4 \log 2}. \end{aligned}$$

From this proposition, we can get the exponential divergence of  $q_3^{(k)}$  as  $k \rightarrow \infty$ .

**Proposition 5.4.**

$$\lim_{k \rightarrow \infty} \frac{1}{k} \log q_3^{(k)} = \frac{\pi^2}{12 \log 2}$$

for  $\lambda$ -a.e.  $(x, y)$ .

Proof. From the Shannon-MacMillan-Breiman theorem, we have

$$-\lim_{k \rightarrow \infty} \frac{1}{k} \log \mu(\Delta_k) = \frac{\pi^2}{4 \log 2} \quad \mu\text{-a.e.}$$

where  $\Delta_k$  is defined by  $(\varepsilon_i, n_i, m_i) = (\varepsilon_i(x, y), n_i(x, y), m_i(x, y))$  for  $1 \leq i \leq k$ . We take  $(x, y)$  so that (5.1) holds. Then we choose a subsequence  $(l_k) : k \geq 1$  by

$$l_1 = \min\{l \geq 1 \mid (\varepsilon_l(x, y), n_l(x, y), m_l(x, y)) \neq (+1, 1, 1)\}$$

and

$$l_{k+1} = \min\{l > l_k \mid (\varepsilon_l(x, y), n_l(x, y), m_l(x, y)) \neq (+1, 1, 1)\}$$

for  $k \geq 1$ , which means that we choose all cylinders  $\Delta_l \in R(T)$ . Since  $\Delta_l$  is bounded away from 0, there exists a constant  $C_1 > 1$  such that

$$\frac{1}{C_1} \lambda(\Delta_{l_k}) < \mu(\Delta_{l_k}) < C_1 \lambda(\Delta_{l_k}).$$

On the other hand, there exists a constant  $C_2 > 1$  such that

$$\frac{1}{C_2 q_3^{(l)}} < \lambda(\Delta_l) < \frac{C_2}{q_3^{(l)}}$$

whenever  $\Delta_l \in R(T)$ , see Lemma 4.3. Thus we get

$$\lim_{k \rightarrow \infty} \frac{1}{l_k} \log q_3^{(l_k)} = \frac{\pi^2}{12 \log 2}$$

for  $\mu$ -a.e.  $(x, y)$ . It is clear that  $q_3^{(k+1)} = q_3^{(k)}$  if  $(\varepsilon_k(x, y), n_k(x, y), m_k(x, y)) = (+1, 1, 1)$ . Since the indicator function of  $\langle (+1, 1, 1) \rangle$  is obviously integrable with respect to  $\mu$ ,

$$\lim_{k \rightarrow \infty} \frac{l_k - l_{k-1}}{l_k} = 0$$

for  $\mu$ -a.e.  $(x, y)$ . Hence we have

$$\lim_{l \rightarrow \infty} \frac{1}{l} \log q_3^{(l)} = \frac{\pi^2}{12 \log 2}$$

for  $\mu$ -a.e.  $(x, y)$ , equivalently  $\lambda$ -a.e.

REMARK 5.5. It is easy to see that

$$\left( \frac{p_3^{(k)}}{q_3^{(k)}}, \frac{r_3^{(k)}}{q_3^{(k)}} \right), \quad \left( \frac{p_1^{(k)} + p_3^{(k)}}{q_1^{(k)} + q_3^{(k)}}, \frac{r_1^{(k)} + r_3^{(k)}}{q_1^{(k)} + q_3^{(k)}} \right), \quad \left( \frac{p_2^{(k)} + p_3^{(k)}}{q_2^{(k)} + q_3^{(k)}}, \frac{r_2^{(k)} + r_3^{(k)}}{q_2^{(k)} + q_3^{(k)}} \right),$$

and

$$\left( \frac{p_1^{(k)} + p_2^{(k)} + p_3^{(k)}}{q_1^{(k)} + q_2^{(k)} + q_3^{(k)}}, \frac{r_1^{(k)} + r_2^{(k)} + r_3^{(k)}}{q_1^{(k)} + q_2^{(k)} + q_3^{(k)}} \right)$$

are  $\Psi_{\Delta_k}(0, 0)$ ,  $\Psi_{\Delta_k}(1, 0)$ ,  $\Psi_{\Delta_k}(0, 1)$ , and  $\Psi_{\Delta_k}(1, 1)$ , respectively. Then it is also possible to show that

$$\lim_{k \rightarrow \infty} \frac{1}{k} (\log q_1^{(k)} + \log q_2^{(k)} + \log q_3^{(k)}) = \frac{\pi^2}{12 \log 2}$$

for  $\lambda$ -a.e.  $(x, y)$  by the same way. We note that these four sequences converge to  $(x, y)$  because of (C.1). Suppose that

$$d(k, x, y) = \text{diameter}(\langle (\varepsilon_1, n_1, m_1), (\varepsilon_2, n_2, m_2), \dots, (\varepsilon_k, n_k, m_k) \rangle).$$

Then the convergence rate of the above four sequences to  $(x, y)$  is bounded by  $d(k, x, y)$ .

## 6 Characterization of periodic points of the negative slope algorithm

In this section, we characterize periodic points of the negative slope algorithm by using the natural extension method. First, we show the properties of representation matrices of the negative slope algorithm.

### 6.1 Some properties of the negative slope algorithm

**Lemma 6.1.** *For entries of  $\Psi_{\Delta_k}$ , we have*

$$\begin{cases} p_1^{(k)} &= p_2^{(k)} + \varepsilon_1 \cdots \varepsilon_k \\ r_1^{(k)} &= r_2^{(k)} - \varepsilon_1 \cdots \varepsilon_k \\ q_1^{(k)} &= q_2^{(k)} \end{cases}.$$

*Proof.* By simple calculation, we see that

$$\begin{pmatrix} 1 & 0 & n-1 \\ 0 & 1 & m-1 \\ 1 & 1 & n+m-1 \end{pmatrix} \begin{pmatrix} 1 \\ -1 \\ 0 \end{pmatrix} = (+1) \begin{pmatrix} 1 \\ -1 \\ 0 \end{pmatrix}$$

$$\begin{pmatrix} 0 & 1 & m \\ 1 & 0 & n \\ 1 & 1 & n+m-1 \end{pmatrix} \begin{pmatrix} 1 \\ -1 \\ 0 \end{pmatrix} = (-1) \begin{pmatrix} 1 \\ -1 \\ 0 \end{pmatrix}.$$

So we have

$$A_{(\varepsilon, n, m)}^{-1} \begin{pmatrix} 1 \\ -1 \\ 0 \end{pmatrix} = \varepsilon \begin{pmatrix} 1 \\ -1 \\ 0 \end{pmatrix}.$$

Then we see that

$$A_{(\varepsilon_1, n_1, m_1)}^{-1} \cdots A_{(\varepsilon_k, n_k, m_k)}^{-1} \begin{pmatrix} 1 \\ -1 \\ 0 \end{pmatrix} = \varepsilon_1 \cdots \varepsilon_k \begin{pmatrix} 1 \\ -1 \\ 0 \end{pmatrix}$$

for  $k \geq 1$ . Therefore, we obtain

$$\begin{pmatrix} p_1^{(k)} - p_2^{(k)} \\ r_1^{(k)} - r_2^{(k)} \\ q_1^{(k)} - q_2^{(k)} \end{pmatrix} = \begin{pmatrix} \varepsilon_1 \cdots \varepsilon_k \\ -\varepsilon_1 \cdots \varepsilon_k \\ 0 \end{pmatrix}.$$

□

We next give an approximation of  $(x + y)$  for  $(x, y) \in \mathbb{X}$ .

**Lemma 6.2.** *For  $(x, y) \in \mathbb{X}$ , we have*

$$\left| (x + y) - \left( \frac{p_3^{(k)} + r_3^{(k)}}{q_3^{(k)}} \right) \right| < \frac{1}{q_2^{(k)} q_3^{(k)}}.$$

*Proof.* By taking a determinant of  $\Psi_{\Delta_k}$ , we have

$$\begin{vmatrix} p_1^{(k)} & p_2^{(k)} & p_3^{(k)} \\ r_1^{(k)} & r_2^{(k)} & r_3^{(k)} \\ q_1^{(k)} & q_2^{(k)} & q_3^{(k)} \end{vmatrix} = p_1^{(k)} \begin{vmatrix} r_2^{(k)} & r_3^{(k)} \\ q_2^{(k)} & q_3^{(k)} \end{vmatrix} - p_2^{(k)} \begin{vmatrix} r_1^{(k)} & r_3^{(k)} \\ q_1^{(k)} & q_3^{(k)} \end{vmatrix} + p_3^{(k)} \begin{vmatrix} r_1^{(k)} & r_2^{(k)} \\ q_1^{(k)} & q_2^{(k)} \end{vmatrix}.$$

From Lemma 2.1, the right hand side is equal to

$$(p_2^{(k)} + \delta_k) \begin{vmatrix} r_2^{(k)} & r_3^{(k)} \\ q_2^{(k)} & q_3^{(k)} \end{vmatrix} - p_2^{(k)} \begin{vmatrix} r_2^{(k)} - \delta_k & r_3^{(k)} \\ q_1^{(k)} & q_3^{(k)} \end{vmatrix} + p_3^{(k)} \begin{vmatrix} r_2^{(k)} - \delta_k & r_2^{(k)} \\ q_1^{(k)} & q_2^{(k)} \end{vmatrix}$$

where  $\delta_k = \varepsilon_1 \cdots \varepsilon_k$ . Since  $\det \Psi_{\Delta_k} = 1$ , we have

$$(r_2^{(k)} q_3^{(k)} - r_3^{(k)} q_2^{(k)}) + (p_2^{(k)} q_3^{(k)} - p_3^{(k)} q_2^{(k)}) = 1. \quad (6.1)$$

Substituting  $p_1^{(k)} = p_2^{(k)} + \delta_k$ ,  $r_1^{(k)} = r_2^{(k)} - \delta_k$  and  $q_1^{(k)} = q_2^{(k)}$  for (6.1), we see that

$$(r_1^{(k)} q_3^{(k)} - r_3^{(k)} q_1^{(k)}) + (p_1^{(k)} q_3^{(k)} - p_3^{(k)} q_1^{(k)}) = 1. \quad (6.2)$$

From (6.1) and (6.2), we have

$$\frac{p_1^{(k)} + r_1^{(k)}}{q_1^{(k)}} = \frac{p_2^{(k)} + r_2^{(k)}}{q_2^{(k)}} = \frac{p_3^{(k)} + r_3^{(k)}}{q_3^{(k)}} + \frac{1}{q_2^{(k)} q_3^{(k)}}. \quad (6.3)$$

For  $(x, y) \in \mathbb{X}$ , we put  $(x_k, y_k) = T^k(x, y)$ ,  $k \geq 1$ . Then we see that

$$\begin{pmatrix} \alpha x \\ \alpha y \\ \alpha \end{pmatrix} = \begin{pmatrix} p_1^{(k)} & p_2^{(k)} & p_3^{(k)} \\ r_1^{(k)} & r_2^{(k)} & r_3^{(k)} \\ q_1^{(k)} & q_2^{(k)} & q_3^{(k)} \end{pmatrix} \begin{pmatrix} x_k \\ y_k \\ 1 \end{pmatrix}$$

for  $\alpha \neq 0$ . Then we obtain

$$x = \frac{p_1^{(k)} x_k + p_2^{(k)} y_k + p_3^{(k)}}{q_1^{(k)} x_k + q_2^{(k)} y_k + q_3^{(k)}}, \quad (6.4)$$

$$y = \frac{r_1^{(k)} x_k + r_2^{(k)} y_k + r_3^{(k)}}{q_1^{(k)} x_k + q_2^{(k)} y_k + q_3^{(k)}}. \quad (6.5)$$

Since  $q_3^{(k)} > 0$  for  $k \geq 1$ , the denominators of the above two equations are not equal to 0. From  $p_1^{(k)} = p_2^{(k)} + \delta_k$ ,  $r_1^{(k)} = r_2^{(k)} - \delta_k$  and  $q_1^{(k)} = q_2^{(k)}$ , we have

$$x + y = \frac{(p_2^{(k)} + r_2^{(k)})(x_k + y_k) + (p_3^{(k)} + r_3^{(k)})}{q_2^{(k)}(x_k + y_k) + q_3^{(k)}}. \quad (6.6)$$

Then we see the following.

$$\begin{aligned} \left| (x + y) - \left( \frac{p_3^{(k)} + r_3^{(k)}}{q_3^{(k)}} \right) \right| &= \left| \frac{(p_2^{(k)} + r_2^{(k)})(x_k + y_k) + (p_3^{(k)} + r_3^{(k)})}{q_2^{(k)}(x_k + y_k) + q_3^{(k)}} - \left( \frac{p_3^{(k)} + r_3^{(k)}}{q_3^{(k)}} \right) \right| \\ &= \left| \left( \frac{p_2^{(k)} + r_2^{(k)}}{q_2^{(k)}} + \frac{-\frac{q_3^{(k)}}{q_2^{(k)}}(p_2^{(k)} + r_2^{(k)}) + (p_3^{(k)} + r_3^{(k)})}{q_2^{(k)}(x_k + y_k) + q_3^{(k)}} \right) - \left( \frac{p_3^{(k)} + r_3^{(k)}}{q_3^{(k)}} \right) \right|. \end{aligned}$$

From (6.1) and (6.3), we see that the second line is equal to

$$\left| \frac{1}{q_2^{(k)} q_3^{(k)}} - \frac{1}{q_2^{(k)} q_2^{(k)}(x_k + y_k) + q_3^{(k)}} \right| < \left| \frac{1}{q_2^{(k)} q_3^{(k)}} \right|.$$

This is the assertion of this lemma.  $\square$



From (6.3) and from this lemma, we deduce the following approximations.

$$\left| (x + y) - \frac{p_i^{(k)} + r_i^{(k)}}{q_i^{(k)}} \right| < \frac{2}{q_2^{(k)} q_3^{(k)}} \quad (6.7)$$

for  $i = 1, 2$ .

**Lemma 6.3.** *We put  $(x_k, y_k) = T^k(x, y)$ ,  $k \geq 1$  for  $(x, y) \in \mathbb{X}$ . Then we have*

$$x_k + y_k = -\frac{q_3^{(k)} (x + y) - \left( \frac{p_3^{(k)} + r_3^{(k)}}{q_3^{(k)}} \right)}{q_2^{(k)} (x + y) - \left( \frac{p_2^{(k)} + r_2^{(k)}}{q_2^{(k)}} \right)}$$

where  $p_i^{(k)}, q_i^{(k)}$  and  $r_i^{(k)}$ ,  $i = 1, 2, 3$ , are the entries of  $\Psi_{\Delta_k}$ .

*Proof.* We consider the inverse of  $\Psi_{\Delta_k}$ . We put  $(x_k, y_k) = T^k(x, y)$ ,  $k \geq 1$  for  $(x, y) \in \mathbb{X}$ . Then we have

$$\begin{pmatrix} \alpha x_k \\ \alpha y_k \\ \alpha \end{pmatrix} = \begin{pmatrix} p_1^{(k)} & p_2^{(k)} & p_3^{(k)} \\ r_1^{(k)} & r_2^{(k)} & r_3^{(k)} \\ q_1^{(k)} & q_2^{(k)} & q_3^{(k)} \end{pmatrix}^{-1} \begin{pmatrix} x \\ y \\ 1 \end{pmatrix}.$$

for  $\alpha \neq 0$ . By taking the cofactor matrix of  $\Psi_{\Delta_k}$ , the inverse is equal to

$$\Psi_{\Delta_k}^{-1} = \begin{pmatrix} \left| \begin{array}{cc} r_2^{(k)} & r_3^{(k)} \\ q_2^{(k)} & q_3^{(k)} \end{array} \right| & - \left| \begin{array}{cc} p_2^{(k)} & p_3^{(k)} \\ q_2^{(k)} & q_3^{(k)} \end{array} \right| & \left| \begin{array}{cc} p_2^{(k)} & p_3^{(k)} \\ r_2^{(k)} & r_3^{(k)} \end{array} \right| \\ - \left| \begin{array}{cc} r_1^{(k)} & r_3^{(k)} \\ q_1^{(k)} & q_3^{(k)} \end{array} \right| & \left| \begin{array}{cc} p_1^{(k)} & p_3^{(k)} \\ q_1^{(k)} & q_3^{(k)} \end{array} \right| & - \left| \begin{array}{cc} p_1^{(k)} & p_3^{(k)} \\ r_1^{(k)} & r_3^{(k)} \end{array} \right| \\ \left| \begin{array}{cc} r_1^{(k)} & r_2^{(k)} \\ q_1^{(k)} & q_2^{(k)} \end{array} \right| & - \left| \begin{array}{cc} p_1^{(k)} & p_2^{(k)} \\ q_1^{(k)} & q_2^{(k)} \end{array} \right| & \left| \begin{array}{cc} p_1^{(k)} & p_2^{(k)} \\ r_1^{(k)} & r_2^{(k)} \end{array} \right| \end{pmatrix}.$$

Then we have

$$\begin{aligned} x_k &= \frac{(r_2^{(k)} q_3^{(k)} - r_3^{(k)} q_2^{(k)})x + (-p_2^{(k)} q_3^{(k)} + p_3^{(k)} q_2^{(k)})y + (p_2^{(k)} r_3^{(k)} - p_3^{(k)} r_2^{(k)})}{(r_1^{(k)} q_2^{(k)} - r_2^{(k)} q_1^{(k)})x + (-p_1^{(k)} q_2^{(k)} + p_2^{(k)} q_1^{(k)})y + (p_1^{(k)} r_2^{(k)} - p_2^{(k)} r_1^{(k)})}, \\ y_k &= \frac{(-r_1^{(k)} q_3^{(k)} + r_3^{(k)} q_1^{(k)})x + (p_1^{(k)} q_3^{(k)} - p_3^{(k)} q_1^{(k)})y + (-p_1^{(k)} r_3^{(k)} + p_3^{(k)} r_1^{(k)})}{(r_1^{(k)} q_2^{(k)} - r_2^{(k)} q_1^{(k)})x + (-p_1^{(k)} q_2^{(k)} + p_2^{(k)} q_1^{(k)})y + (p_1^{(k)} r_2^{(k)} - p_2^{(k)} r_1^{(k)})}. \end{aligned} \quad (6.8)$$

From Lemma 6.1, we have the following.

$$\begin{aligned}
x_k + y_k &= \frac{(\varepsilon_1 \cdots \varepsilon_k) q_3^{(k)} x + (\varepsilon_1 \cdots \varepsilon_k) q_3^{(k)} y - (\varepsilon_1 \cdots \varepsilon_k) (p_3^{(k)} + r_3^{(k)})}{-(\varepsilon_1 \cdots \varepsilon_k) q_2^{(k)} x - (\varepsilon_1 \cdots \varepsilon_k) q_2^{(k)} y + (\varepsilon_1 \cdots \varepsilon_k) (p_2^{(k)} + r_2^{(k)})} \\
&= -\frac{q_3^{(k)} (x + y) - \left( \frac{p_3^{(k)} + r_3^{(k)}}{q_3^{(k)}} \right)}{q_2^{(k)} (x + y) - \left( \frac{p_2^{(k)} + r_2^{(k)}}{q_2^{(k)}} \right)}.
\end{aligned}$$

□

## 6.2 The case where the negative slope algorithm stops

Next we denote the notation that iteration by the negative slope algorithm  $T$  of  $(x, y) \in \mathbb{X}$  stops and give a necessary condition for  $(x, y) \in \mathbb{X}$  stopping after finite steps.

**Definition 6.4.** We denote  $k$ -th iteration by the negative slope algorithm  $T$  of  $(x, y) \in \mathbb{X}$  as  $(x_k, y_k) = T^k(x, y)$ . Then we say iteration by the negative slope algorithm  $T$  of  $(x, y) \in \mathbb{X}$  stops if there exists  $k_0 \geq 0$  such that  $x_{k_0} = 0$  or  $y_{k_0} = 0$  or  $x_{k_0} + y_{k_0} = 1$ .

This implies that iteration by the negative slope algorithm  $T$  of  $(x, y) \in \mathbb{X}$  stops if there exists  $k_0 \geq 0$  s.t.  $(x_{k_0}, y_{k_0}) \in \partial\mathbb{X}$ . From this definition, we get the following propositions.

**Proposition 6.5.** If iteration by the negative slope algorithm  $T$  of  $(x, y) \in \mathbb{X}$  stops, then  $(x, y)$  satisfies one of the following equations.

$$\begin{aligned}
(p + 1)x + py &= q \\
px + (p + 1)y &= q \\
px + py &= q
\end{aligned}$$

for some integers  $0 \leq q \leq 2p$ .

*Proof.* We put  $k$ -th iteration by the negative slope algorithm  $T$  of  $(x, y) \in \mathbb{X}$  as  $(x_k, y_k) = T^k(x, y)$ . Suppose  $x_k = 0$ , then we get the following equation from (6.8) in Lemma 6.3.

$$0 = (r_2^{(k)} q_3^{(k)} - r_3^{(k)} q_2^{(k)})x + (-p_2^{(k)} q_3^{(k)} + p_3^{(k)} q_2^{(k)})y + (p_2^{(k)} r_3^{(k)} - p_3^{(k)} r_2^{(k)}).$$

By (6.1) in Lemma 6.2, we obtain

$$(p + 1)x + py = q$$

where  $p = -p_2^{(k)} q_3^{(k)} + p_3^{(k)} q_2^{(k)}$ ,  $q = -p_2^{(k)} r_3^{(k)} + p_3^{(k)} r_2^{(k)}$ . Since

$$x = \frac{q - py}{p + 1} \in [0, 1],$$

we see that the following two cases.

(i) If  $0 \leq q - py \leq p + 1$ , then

$$0 \leq py \leq q \leq (y + 1)p + 1 \leq 2p + 1.$$

(ii) If  $0 \geq q - py \geq p + 1$ , then

$$0 \geq py \geq q \geq (y + 1)p + 1 \geq 2p + 1 > 2p.$$

Similarly, we obtain  $px + (p + 1)y = 0$  ( $0 \leq q \leq 2p$ ) for  $y_k = 0$ .

Suppose  $x_k + y_k = 1$ , then we get the following by (6.6) in Lemma 6.2

$$(q_2^{(k)} + q_3^{(k)})(x + y) = (p_2^{(k)} + p_3^{(k)}) + (r_2^{(k)} + r_3^{(k)}).$$

Since  $0 \leq x + y \leq 2$ , we complete the proof.  $\square$

In the following, we show the sufficient condition for the third equation in Proposition 6.5.

**Proposition 6.6.** *If  $(x, y) \in \mathbb{X}$  satisfies the following equation,*

$$px + py = q$$

*for any integers  $0 \leq q \leq 2p$ , then there exists  $N > 0$  such that the sequence  $(T^k(x, y) : k \geq 0)$  terminates at  $k = N$  for the negative slope algorithm  $T$ .*

*Proof.* Suppose  $|x + y - 1| = \frac{t_1}{t_0} < 1$  for  $(x, y) \in \mathbb{X}$  where  $\frac{t_1}{t_0}$  is an irreducible fraction. Then by the negative slope algorithm, we see that

$$|x_1 + y_1 - 1| = \left| \frac{t_0}{t_1} - (n_1(x, y) + m_1(x, y)) \right| = \left| \frac{t_2}{t_1} \right| < 1$$

where  $\frac{t_2}{t_1}$  is also an irreducible fraction. Recursively, we get

$$|x_{i+1} + y_{i+1} - 1| = \left| \frac{t_i}{t_{i+1}} - (n_{i+1}(x, y) + m_{i+1}(x, y)) \right| = \left| \frac{t_{i+2}}{t_{i+1}} \right| < 1$$

where  $\frac{t_{i+2}}{t_{i+1}}$  is an irreducible fraction. Since  $(|t_i| : i \geq 0)$  is a decreasing integer sequence, there exists  $N > 0$  s.t.  $t_N = 0$ . This implies that the sequence  $(T^k(x, y) : k \geq 0)$  stops at  $k = N - 1$ .  $\square$

Finally, we give the last lemma of this section. This lemma shows that the condition for the existence of an expansion of  $(x, y) \in \mathbb{X}$  by the negative slope algorithm.

**Lemma 6.7.** *For  $n_i, m_i \geq 1$ ,  $i \geq 1$  and for any sequence  $((\varepsilon_i, n_i, m_i), i \geq 1)$ , there exists  $(x, y) \in \mathbb{X}$  such that  $(\varepsilon_i(x, y), n_i(x, y), m_i(x, y)) = (\varepsilon_i, n_i, m_i)$  unless there exists  $k \geq 1$  such that  $(\varepsilon_i, m_i) = (+1, 1)$  for  $i \geq k$  or  $(\varepsilon_i, n_i) = (+1, 1)$  for  $i \geq k$ .*

*Proof.* Suppose there exists  $(x, y) \in \mathbb{X}$  satisfying  $(\varepsilon_i(x, y), n_i(x, y)) = (+1, 1)$  for all  $i \geq 1$ . Then the negative slope expansion of  $(x, y)$  is  $((+1, 1, m_1), (+1, 1, m_2), \dots)$  for  $m_i \geq 1$ ,  $i \geq 1$ . So we have

$$\begin{aligned} A_{(+1,1,m_1)}^{-1} \cdot A_{(+1,1,m_2)}^{-1} &= \begin{pmatrix} 1 & 0 & 0 \\ 0 & 1 & m_1 - 1 \\ 1 & 1 & m_1 \end{pmatrix} \begin{pmatrix} 1 & 0 & 0 \\ 0 & 1 & m_2 - 1 \\ 1 & 1 & m_2 \end{pmatrix} \\ &= \begin{pmatrix} 1 & 0 & 0 \\ m_1 - 1 & m_1 - 1 & m_1(m_2 - 1) \\ m_1 + 1 & m_1 + 1 & 2m_2 - 1 \end{pmatrix} \end{aligned}$$

and

$$\begin{aligned} \begin{pmatrix} p_1^{(i+1)} & p_2^{(i+1)} & p_3^{(i+1)} \\ r_1^{(i+1)} & r_2^{(i+1)} & r_3^{(i+1)} \\ q_1^{(i+1)} & q_2^{(i+1)} & q_3^{(i+1)} \end{pmatrix} &= \begin{pmatrix} p_1^{(i)} & p_2^{(i)} & p_3^{(i)} \\ r_1^{(i)} & r_2^{(i)} & r_3^{(i)} \\ q_1^{(i)} & q_2^{(i)} & q_3^{(i)} \end{pmatrix} \begin{pmatrix} 1 & 0 & 0 \\ 0 & 1 & m_{i+1} - 1 \\ 1 & 1 & m_{i+1} \end{pmatrix} \\ &= \begin{pmatrix} p_1^{(i)} + p_3^{(i)} & p_2^{(i)} + p_3^{(i)} & (m_{i+1} - 1)p_2^{(i)} + (m_{i+1})p_3^{(i)} \\ r_1^{(i)} + r_3^{(i)} & r_2^{(i)} + r_3^{(i)} & (m_{i+1} - 1)r_2^{(i)} + (m_{i+1})r_3^{(i)} \\ q_1^{(i)} + q_3^{(i)} & q_2^{(i)} + q_3^{(i)} & (m_{i+1} - 1)q_2^{(i)} + (m_{i+1})q_3^{(i)} \end{pmatrix} \end{aligned}$$

for  $i \geq 2$ . If we put  $p_1^{(i)} = 1$ ,  $p_2^{(i)} = p_3^{(i)} = 0$ , then we have  $p_1^{(i+1)} = 1$ ,  $p_2^{(i+1)} = p_3^{(i+1)} = 0$ . Therefore we obtain  $p_1^{(i)} = 1$ ,  $p_2^{(i)} = p_3^{(i)} = 0$  for all  $i \geq 1$ . From (6.4) in Lemma 6.2, we see that

$$x = \frac{x_k}{q_1^{(k)} x_k + q_2^{(k)} y_k + q_3^{(k)}}$$

where  $(x_k, y_k)$  is  $k$ -th iteration by the negative slope algorithm. Since  $q_i^{(k)}$ ,  $i = 1, 2, 3$  are increasing integer sequences and  $(x_k, y_k) \in \mathbb{X}$ , this implies that  $x = 0$  for  $k \rightarrow \infty$ . Then it is the contradiction to Definition 6.4.  $\square$

## 7 The natural extension of the negative slope algorithm and characterization of periodic points

In this section, we recall the 4-dimensional map  $\bar{T}$  which is called the natural extension of the negative slope algorithm  $T$ . This map has been given in §4. It was defined as the natural extension of the negative slope algorithm on  $\mathbb{R}^4$  as follows. Let  $\bar{\mathbb{X}} = \mathbb{X} \times (-\infty, 0)^2$ . For  $(x, y, z, w) \in \bar{\mathbb{X}}$ , we define a map  $\bar{T}$  on  $\bar{\mathbb{X}}$  by

$$\begin{aligned} & \overline{T}(x, y, z, w) \\ &= \begin{cases} \left( \frac{y}{(x+y)-1} - n(x, y), \frac{x}{(x+y)-1} - m(x, y), \frac{w}{(z+w)-1} - n(x, y), \frac{z}{(z+w)-1} - m(x, y) \right) \\ \quad \text{if } x + y > 1 \\ \left( \frac{1-y}{1-(x+y)} - n(x, y), \frac{1-x}{1-(x+y)} - m(x, y), \frac{1-w}{1-(z+w)} - n(x, y), \frac{1-z}{1-(z+w)} - m(x, y) \right) \\ \quad \text{if } x + y < 1. \end{cases} \end{aligned}$$

Then it is easy to see that  $\overline{T}$  is bijective on  $\overline{\mathbb{X}}$  except for the boundary of  $\overline{\mathbb{X}}$ . We prove Theorem 7.1 in this section. After the proof of Theorem 7.1, we show Corollary 7.12 as a corollary of Theorem 7.1.

**Theorem 7.1.** *Suppose iteration by the negative slope algorithm  $T$  of  $(x, y) \in \mathbb{X}$  does not stop. Then the sequence  $(T^k(x, y) : k \geq 0)$  is purely periodic if and only if  $x$  and  $y$  are in the same quadratic extension of  $\mathbb{Q}$  and  $(x, y, x^*, y^*) \in \overline{\mathbb{X}}$  where  $x^*$  denotes the algebraic conjugate of  $x$ .*

## 7.1 Necessary part of Theorem 7.1

We start with proving the necessary condition of Theorem 7.1. First, we show that if iteration by  $T$  of  $(x, y) \in \mathbb{X}$  is purely periodic, then there exists square free  $d > 0$  s.t.  $x, y$  are in  $\mathbb{Q}(\sqrt{d})$ . After that, we show that iteration by  $\overline{T}$  of  $(x, y, z, w) \in \mathbb{X} \times \mathbb{R}^2 \setminus \{(x, y, z, w) \mid z + w = x + y, (z, w) \in \mathbb{X}\}$  goes into  $\overline{\mathbb{X}}$ .

**Lemma 7.2.** *Suppose iteration by the negative slope algorithm  $T$  of  $(x, y) \in \mathbb{X}$  does not stop. Then if the sequence  $(T^k(x, y) : k \geq 0)$  is purely periodic, there exists square free  $d > 0$  such that  $x$  and  $y$  are in  $\mathbb{Q}(\sqrt{d})$ .*

*Proof.* Suppose the sequence  $(T^k(x, y) : k \geq 0)$  is purely periodic for  $(x, y) \in \mathbb{X}$  by the negative slope algorithm  $T$ , then there exists  $l > 0$  such that  $T^l(x, y) = (x, y) \in \mathbb{X}$ . From (6.6) in Lemma 6.2, we see that

$$x + y = \frac{(p_2^{(l)} + r_2^{(l)})(x + y) + (p_3^{(l)} + r_3^{(l)})}{q_2^{(l)}(x + y) + q_3^{(l)}}.$$

Then we have the following quadratic equation with respect to  $(x + y)$ .

$$q_2^{(l)}(x + y)^2 + (q_3^{(l)} - p_2^{(l)} - r_2^{(l)})(x + y) - (p_3^{(l)} + r_3^{(l)}) = 0.$$

We see that the discriminant  $d$  of this equation satisfies

$$d = (q_3^{(l)} - p_2^{(l)} - r_2^{(l)})^2 + 4q_2^{(l)}(p_3^{(l)} + r_3^{(l)}) > 0.$$

Note that the discriminant  $d > 0$  is not a square number. In fact, suppose  $d$  is a square number, then we see that  $x + y \in \mathbb{Q}$ . It implies that there exists  $N > 0$  such that the sequence  $(T^k(x, y) : k \geq 0)$  stops at  $k = N$  by Proposition 6.6. This contradicts the fact that the sequence  $(T^k(x, y) : k \geq 0)$  is purely periodic. Therefore,  $d$  is not a square number and  $x + y \in \mathbb{Q}(\sqrt{d})$ . From Lemma 6.1, (6.4) and (6.5), we have

$$x = \frac{p_2^{(k)}(x+y) + p_3^{(k)}}{q_2^{(k)}(x+y) + q_3^{(k)} - (\varepsilon_1 \cdots \varepsilon_k)},$$

$$y = \frac{r_2^{(k)}(x+y) + r_3^{(k)}}{q_2^{(k)}(x+y) + q_3^{(k)} + (\varepsilon_1 \cdots \varepsilon_k)}.$$

This is the assertion of this lemma.  $\square$

In the following, we put  $(x_k, y_k, z_k, w_k) = \bar{T}^k(x, y, z, w), k \geq 0$  for the natural extension  $\bar{T}$  of the negative slope algorithm  $T$ . We show that if iteration by  $T$  of  $(x, y)$  does not stop for  $(x, y, z, w) \in \mathbb{X} \times \mathbb{R}^2 \setminus \{(x, y, z, w) \mid z + w = x + y, (z, w) \in \mathbb{X}\}$ , then  $\exists k_0 > 0$  s.t.  $(z_k, w_k) \in (-\infty, 0)^2$  for  $k > k_0$ . This will yield the necessary condition of Theorem 7.1.

**Lemma 7.3.** *Let  $(x, y, z, w) \in \mathbb{X} \times \mathbb{R}^2 \setminus \{(x, y, z, w) \mid z + w = x + y, (z, w) \in \mathbb{X}\}$  and  $(x_k, y_k, z_k, w_k) = \bar{T}^k(x, y, z, w), k \geq 0$  for the natural extension  $\bar{T}$  of the negative slope algorithm  $T$ . Suppose the sequence  $(T^k(x, y) : k \geq 0)$  does not terminate at any finite number  $k$ . Then there exists  $k_0 > 0$  such that  $z_k + w_k < 0$  for  $k > k_0$ .*

*Proof.* Suppose the sequence  $(T^k(x, y) : k \geq 0)$  for  $(x, y) \in \mathbb{X}$  does not terminate at any finite number  $k$ . Then from Lemma 6.3, we have

$$z_k + w_k = -\frac{q_3^{(k)}(z+w) - \left(\frac{p_3^{(k)} + r_3^{(k)}}{q_3^{(k)}}\right)}{q_2^{(k)}(z+w) - \left(\frac{p_2^{(k)} + r_2^{(k)}}{q_2^{(k)}}\right)}$$

where  $(x_k, y_k, z_k, w_k) = \bar{T}^k(x, y, z, w)$ . According to Lemma 6.2 and (6.7) and  $q_i^{(k)} > 0, i = 2, 3$ , the right hand side converges to  $-\frac{q_3^{(k)}}{q_2^{(k)}}$ . Then there exists  $k_0 > 0$  s.t.

$$z_k + w_k < 0$$

for  $k > k_0$ . This is the assertion of this lemma.  $\square$

Note that it follows from the definition of  $\bar{T}$  that if  $z + w = x + y$ , then we see that  $z_k + w_k = x_k + y_k$  for all  $k \geq 0$ . In fact, it is easy to see that the sequence  $(\bar{T}^k(x, y, z, w) : k \geq 0)$  is not periodic for  $z + w = x + y$  even if the sequence  $(T^k(x, y) : k \geq 0)$  is periodic. Consequently, we can ignore  $\{(x, y, z, w) \in \mathbb{X} \times \mathbb{R}^2 \mid z + w = x + y\}$ . The next lemma shows that  $\{(z, w) \mid z + w < 0\}$  goes into  $(-\infty, 0)^2$  by iterating  $\bar{T}$ .

**Lemma 7.4.** *Suppose iteration by the negative slope algorithm  $T$  of  $(x, y) \in \mathbb{X}$  does not stop. Then the negative slope expansion of  $(x, y)$  is an infinite sequence  $((\varepsilon_1, n_1, m_1), (\varepsilon_2, n_2, m_2), \dots)$ . We put*

$$\Lambda_k = \{(z, w) \mid z + w < 0, n(z, w) = k \text{ or } m(z, w) = k\}$$

and

$$l_N = \#\{l \mid (\varepsilon_l, n_l) \neq (+1, 1) \text{ or } (\varepsilon_l, m_l) \neq (+1, 1), l \leq N\}.$$

Then for  $(x, y, z, w) \in \mathbb{X} \times \Lambda_k$ , there exists  $N > 0$  such that for  $l_N > k$ ,

$$\bar{T}^N(x, y, z, w) \in \bar{\mathbb{X}}.$$

*Proof.* We know that  $\bar{\mathbb{X}}$  is  $\bar{T}$ -invariant from §4. Then it is enough to show that the shaded two areas called upper area and lower area at Fig.2 go into  $(-\infty, 0)^2$  by iterating  $\bar{T}$ . We start with lower area at Fig.2. Suppose iteration by the negative slope algorithm  $T$  of  $(x, y) \in \mathbb{X}$  does not stop, then  $(x, y)$  has an infinite expansion by the negative slope algorithm

$$((\varepsilon_1, n_1, m_1), (\varepsilon_2, n_2, m_2), \dots, (\varepsilon_l, n_l, m_l), \dots).$$

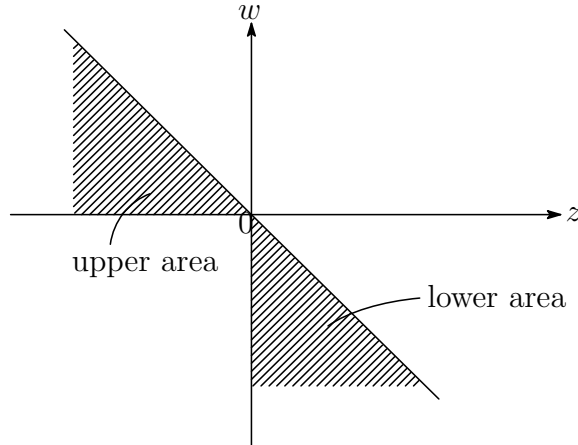

Fig.2

In the following, we consider the two partitions  $\{A_k^{(+)} \mid k = 1, 2, \dots\}$  and  $\{A_k^{(-)} \mid k = 1, 2, \dots\}$  in lower area. First, we define the partition  $A_k^{(\pm)}$  and  $f_{\pm}(z, w)$  as follows.

(i) For  $\varepsilon_1 = +1$ , we define

$$A_k^{(+)} := \left\{ (z, w) \mid \left[ \frac{1-w}{1-(z+w)} \right] = k \right\},$$

$$f_+(z, w) := \left( \frac{1-w}{1-(z+w)}, \frac{1-z}{1-(z+w)} \right).$$

(ii) For  $\varepsilon_1 = -1$ , we define

$$\Lambda_k^{(-)} := \left\{ (z, w) \mid \left[ \frac{w}{(z+w)-1} \right] = k \right\},$$

$$f_-(z, w) := \left( \frac{w}{(z+w)-1}, \frac{z}{(z+w)-1} \right).$$

In the case of  $\varepsilon_1 = +1$ , we see that

$$\bar{T}(x, y, \Lambda_k^{(+)}) = \left( x_1, y_1, f_+(\Lambda_k^{(+)}) - (n_1, m_1) \right)$$

(see Fig.3). We have the following three cases for images by  $\bar{T}$  of  $\Lambda_k^{(+)}$ .

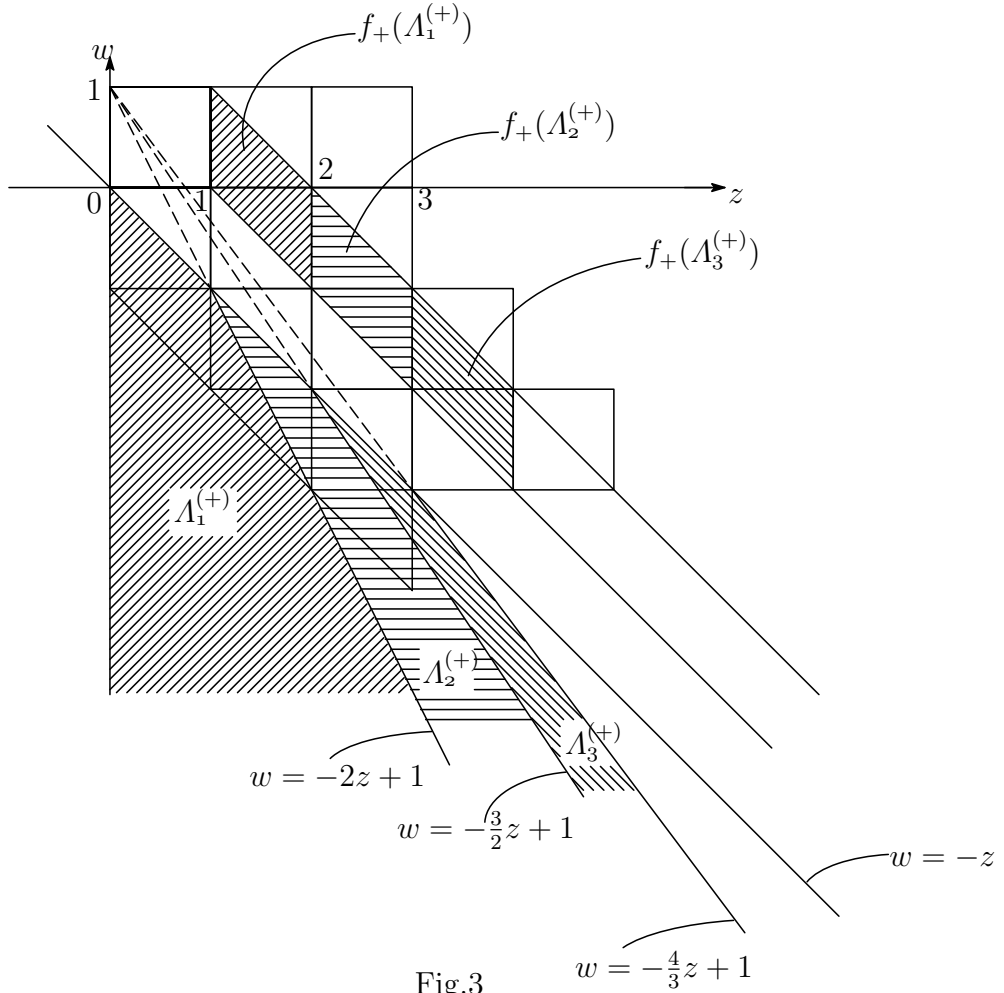



(i-a) For  $n_1 = 1$ , we see that

$$f_+(\Lambda_k^{(+)}) - (1, m_1) \subset \Lambda_1^{(+)} \cup \Lambda_2^{(+)} \cup \dots \cup \Lambda_k^{(+)}$$

$$\text{or } \Lambda_1^{(-)} \cup \Lambda_2^{(-)} \cup \dots \cup \Lambda_k^{(-)}.$$

(i-b) For  $1 < n_1 < k + 1$ , we see that

$$f_+(\Lambda_k^{(+)}) - (n_1, m_1) \subset \Lambda_1^{(+)} \cup \Lambda_2^{(+)} \cup \dots \cup \Lambda_{k-n_1+1}^{(+)}$$

$$\text{or } \Lambda_1^{(-)} \cup \Lambda_2^{(-)} \cup \dots \cup \Lambda_{k-n_1+1}^{(-)}.$$

(i-c) For  $n_1 \geq k + 1$ , we see that

$$f_+(\Lambda_k^{(+)}) - (n_1, m_1) \subset (-\infty, 0)^2.$$

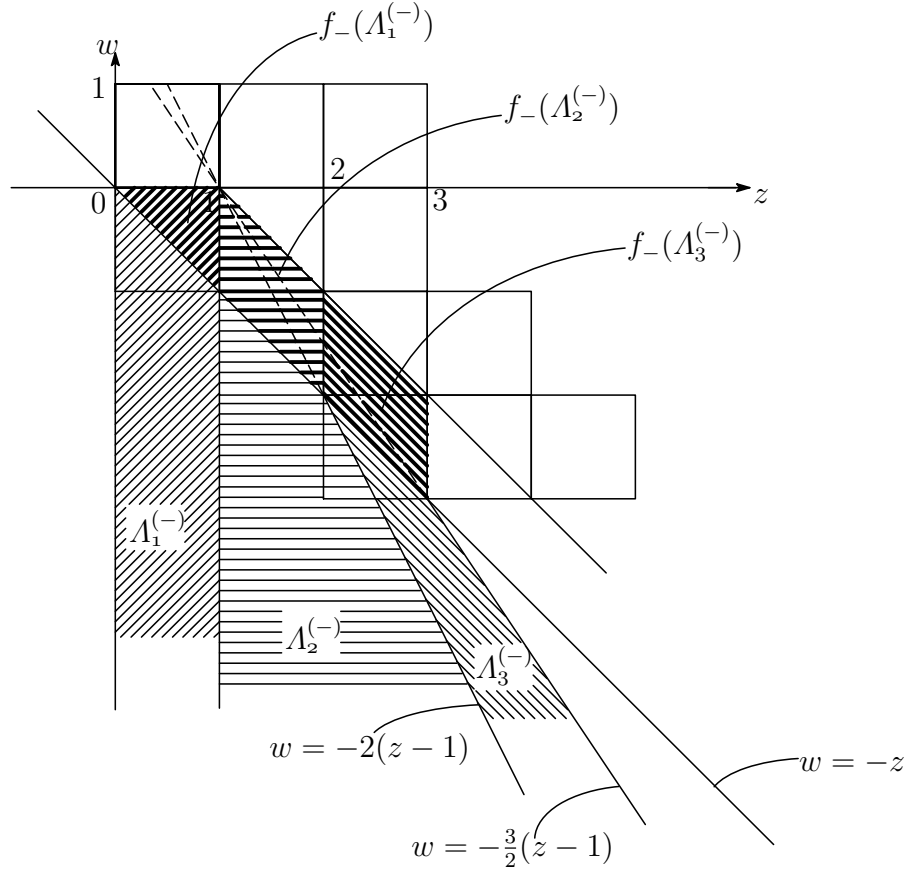

Fig.4

In the case of  $\varepsilon_1 = -1$ , we see that

$$\bar{T}(x, y, \Lambda_k^{(-)}) = (x_1, y_1, f_-(\Lambda_k^{(-)}) - (n_1, m_1))$$

(see Fig.4). We have the following two cases for images by  $\bar{T}$  of  $\Lambda_k^{(-)}$ .

(ii-a) For  $n_1 < k$ , we see that

$$\begin{aligned} f_-(\Lambda_k^{(-)}) - (n_1, m_1) &\subset \Lambda_1^{(+)} \cup \Lambda_2^{(+)} \cup \cdots \cup \Lambda_{k-n_1}^{(+)} \\ &\text{or } \Lambda_1^{(-)} \cup \Lambda_2^{(-)} \cup \cdots \cup \Lambda_{k-n_1}^{(-)}. \end{aligned}$$

(ii-b) For  $n_1 \geq k$ , we see that

$$f_-(\Lambda_k^{(-)}) - (n_1, m_1) \subset (-\infty, 0)^2.$$

From (i) and (ii), we obtain

$$\{f_+(\Lambda_k^{(+)}) - (n_1, m_1)\} \subset \Lambda_1^{\pm} \cup \cdots \cup \Lambda_{k-1}^{(\pm)}$$

except for  $(n_1, m_1) = (1, m_1)$  and

$$\{f_-(\Lambda_k^{(-)}) - (n_1, m_1)\} \subset \Lambda_1^{\pm} \cup \cdots \cup \Lambda_{k-1}^{(\pm)}$$

for any  $(n_1, m_1)$ . From Lemma 2.7, there does not exist  $l_0 > 0$  s.t.  $(\varepsilon_l, n_l) = (+1, 1)$  or  $(\varepsilon_l, m_l) = (+1, 1)$  for all  $l > l_0$ . Therefore, there exists  $K_0 > 0$  such that  $\Lambda_k^{(+)}$  and  $K$ -th iteration by  $\bar{T}$  of  $\Lambda_k^{(+)}$  are disjoint for  $K > K_0$ . So we put

$$l_N = \#\{l : (\varepsilon_l, n_l) \neq (+1, 1) \text{ or } (\varepsilon_l, m_l) \neq (+1, 1), l \leq N\}.$$

Then for  $(z, w) \in \Lambda_k^{(\pm)}$ , there exists  $N > 0$  s.t. for  $l_N > k$ ,

$$\bar{T}^{l_N}(x, y, z, w) \in \bar{\mathbb{X}}.$$

It is the same as upper area in Fig.2, which completes the proof.  $\square$

**REMARK 7.5.** In the following proof, we use the fact that  $\bar{T}^k(x, y, x^*, y^*) = (x_k, y_k, (x_k)^*, (y_k)^*)$ . This is easy to show from the definition of the map  $\bar{T}$ .

$$\begin{aligned} &\bar{T}(x, y, x^*, y^*) \\ &= \begin{cases} \left( \frac{y}{(x+y)-1} - n(x, y), \frac{x}{(x+y)-1} - m(x, y), \frac{y^*}{(x^*+y^*)-1} - n(x, y), \frac{x^*}{(x^*+y^*)-1} - m(x, y) \right) \\ \quad \text{if } x + y > 1 \\ \left( \frac{1-y}{1-(x+y)} - n(x, y), \frac{1-x}{1-(x+y)} - m(x, y), \frac{1-y^*}{1-(x^*+y^*)} - n(x, y), \frac{1-x^*}{1-(x^*+y^*)} - m(x, y) \right) \\ \quad \text{if } x + y < 1. \end{cases} \end{aligned}$$

Since  $n(x, y)$  and  $m(x, y)$  are positive integers, we see that for  $x + y > 1$ ,

$$\begin{aligned} \frac{y^*}{(x^* + y^*) - 1} - n &= \left( \frac{y}{(x + y) - 1} - n \right)^*, \\ \frac{x^*}{(x^* + y^*) - 1} - m &= \left( \frac{x}{(x + y) - 1} - m \right)^*. \end{aligned}$$

These are the same as  $x + y < 1$ . Then we obtain

$$\bar{T}(x, y, x^*, y^*) = (x_1, y_1, (x_1)^*, (y_1)^*).$$

*Proof.* (necessary part of Theorem 7.1) Suppose the sequence  $(T^k(x, y) : k \geq 0)$  is purely periodic for  $(x, y) \in \mathbb{X}$  by the negative slope algorithm  $T$ . Then from Lemma 7.2,  $x$  and  $y$  are in the same quadratic extension of  $\mathbb{Q}$ . So it is easy

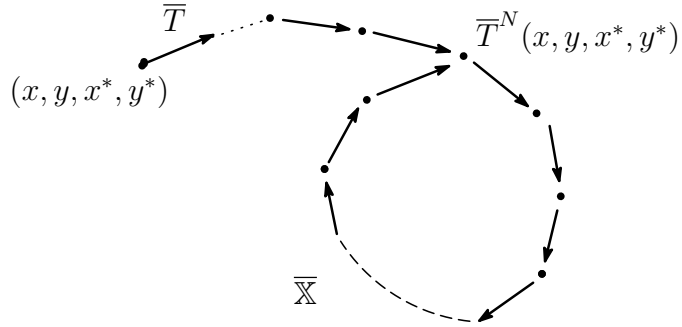

Fig.5

to see that  $(\bar{T}^k(x, y, x^*, y^*) : k \geq 0)$  is purely periodic if  $(T^k(x, y) : k \geq 0)$  is purely periodic, where  $x^*$  is the algebraic conjugate of  $x$ . We show this fact later as Remark 7.5. From Lemma 7.3 and Lemma 7.4, we see that there exists  $N > 0$  such that  $\bar{T}^N(x, y, x^*, y^*) \in \bar{\mathbb{X}}$ . Since  $\bar{\mathbb{X}}$  is  $\bar{T}$ -invariant, we obtain that  $(x, y, x^*, y^*) \in \bar{\mathbb{X}}$  (see Fig.5).  $\square$

## 7.2 Sufficient part of Theorem 7.1

Next, we show the sufficient condition of Theorem 7.1. Suppose  $x$  and  $y$  are in the same quadratic extension of  $\mathbb{Q}$  and  $(x, y, x^*, y^*) \in \bar{\mathbb{X}}$ . Then we show that the number of  $(x, y, x^*, y^*) \in \bar{\mathbb{X}}$  is finite and the orbit of  $(x, y, x^*, y^*)$  by  $\bar{T}$  is purely periodic. We start with some definitions for quadratic irrational numbers.

**Definition 7.6.** *If  $\alpha$  is a quadratic irrational number, then it satisfies the following quadratic equation:*

$$ax^2 + bx + c = 0$$

where  $a, b, c \in \mathbb{Z}$  and the great common measure (GCM) of  $a, b$  and  $c$  is equal to 1. Then we say

$$D = a^2(\alpha - \alpha^*)^2 = b^2 - 4ac$$

is the discriminant of  $\alpha$ , where  $\alpha^*$  is the algebraic conjugate of  $\alpha$ . We also say that  $D$  is the discriminant of  $ax^2 + bx + c = 0$ .

We denote the discriminant of  $\alpha$  as  $D_\alpha$ .

**Definition 7.7.** It is said that  $\alpha$  and  $\alpha'$  are equivalent with respect to modular transformations if they satisfy

$$\alpha = \frac{s\alpha' + t}{u\alpha' + v}$$

where  $s, t, u, v \in \mathbb{Z}$  and  $sv - tu = \pm 1$ .

From definition 7.7, we deduce the following lemmas.

**Lemma 7.8.** If  $\alpha'$  is equivalent to a quadratic irrational number  $\alpha$  with respect to modular transformations, then the discriminant of  $\alpha'$  is equal to the discriminant of  $\alpha$ .

*Proof.* Assume that  $\alpha$  is a quadratic irrational number with the discriminant  $D_\alpha$  and  $\alpha'$  is equivalent to  $\alpha$  w.r.t. modular transformations. Then we have the following.

$$a\alpha^2 + b\alpha + c = 0, \quad GCM(a, b, c) = 1, \quad D_\alpha = b^2 - 4ac. \quad (7.1)$$

$$\alpha = \frac{s\alpha' + t}{u\alpha' + v}, \quad sv - ts = \pm 1. \quad (7.2)$$

From (7.1), (7.2) and simple calculation, we see that  $\alpha'$  is the root of the following equation.

$$(as^2 + bsv + cu^2)x^2 + (2ast + b(sv + tu) + 2cuv)x + (at^2 + btv + cv^2) = 0 \quad (7.3)$$

Then we obtain the discriminant  $D'$  of the above equation as follows.

$$\begin{aligned} D' &= (2ast + b(sv + tu) + 2cuv)^2 - 4(as^2 + bsv + cu^2)(at^2 + btv + cv^2) \\ &= b^2 - 4ac \end{aligned}$$

From assumption,  $GCM(as^2 + bsv + cu^2, 2ast + b(sv + tu) + 2cuv, at^2 + btv + cv^2)$  is equal to 1. This is the assertion of this lemma.  $\square$

**Lemma 7.9.** The cardinality of quadratic equations  $ax^2 + bx + c = 0$  with fixed discriminant where  $a, b, c \in \mathbb{Z}$ ,  $GCM(a, b, c) = 1$ ,  $ac < 0$  is finite.

*Proof.* Let  $D$  be the fixed discriminant of  $ax^2 + bx + c = 0$  where  $a, b, c \in \mathbb{Z}$ ,  $GCM(a, b, c) = 1$ ,  $ac < 0$ . Then we see that

$$D = b^2 - 4ac = b^2 + 4|ac| > b^2.$$

This implies that  $b$  is bounded by  $D$  and the cardinality of a pair  $(a, c)$  is finite for each  $b$ . This is the assertion of this lemma.  $\square$

Note that if  $\alpha$  is the root of quadratic equations of Lemma 7.9, then the cardinality of such  $\alpha$  is also finite.

**Lemma 7.10.** *Assume that  $\alpha$  and  $\beta$  are in the same quadratic extension of  $\mathbb{Q}$  and  $(\alpha, \beta, \alpha^*, \beta^*) \in \overline{\mathbb{X}}$ , then  $D_{\alpha+\beta}$  is greater than  $D_\alpha$  and  $D_\beta$ .*

*Proof.* From the assumption, we see that

$$\begin{aligned} (\alpha, \alpha^*) &= \left( \frac{-b + c\sqrt{\theta}}{a}, \frac{-b - c\sqrt{\theta}}{a} \right), \quad a, c > 0, \quad GCM(a, b, c) = 1 \\ (\beta, \beta^*) &= \left( \frac{-q + r\sqrt{\theta}}{p}, \frac{-q - r\sqrt{\theta}}{p} \right), \quad p, r > 0, \quad GCM(p, q, r) = 1. \end{aligned}$$

where  $\theta$  does not contain square numbers as factors. Then  $\alpha$  and  $\beta$  satisfy the following quadratic equations.

$$\begin{aligned} a^2x^2 + 2abx + b^2 - c^2\theta &= 0, \\ p^2x^2 + 2pqx + q^2 - r^2\theta &= 0. \end{aligned}$$

On the other hand,  $x + y$  satisfies

$$x + y = \frac{(-bp - aq) + (pc + ar)\sqrt{\theta}}{ap}.$$

Then the quadratic equation of  $x + y$  is

$$a^2p^2(x + y)^2 + 2ap(bp + aq)(x + y) + (bp + aq)^2 - (pc + ar)^2\theta = 0.$$

It is enough to show that the following four cases.

(1) If  $GCM(a, b, p, q, \theta) = 1$ , then we see that

$$D_{\alpha+\beta} = 4a^2p^2(pc + ar)^2, \quad D_\alpha = 4a^2c^2\theta, \quad D_\beta = 4p^2r^2\theta.$$

This implies that  $D_{\alpha+\beta} > D_\alpha, D_\beta$ .

(2) If  $GCM(a, p, \theta) = i > 1$ ,  $GCM(a, b, \theta) = 1$  and  $GCM(p, q, \theta) = 1$ , then we see that

$$D_{\alpha+\beta} = 4i^2(a')^2(p')^2(p'c + a'r)^2\theta, \quad D_\alpha = 4a^2c^2\theta, \quad D_\beta = 4p^2r^2\theta$$

where  $a = ia'$  and  $p = ip'$ . This implies that  $D_{\alpha+\beta} > D_\alpha, D_\beta$ .

(3) If  $GCM(a, b, p, \theta) = j > 1$  and  $GCM(p, q, \theta) = 1$ , then we see that

$$D_{\alpha+\beta} = 4j^2(a')^2(p')^2(p'c + a'r)^2\theta, \quad D_\alpha = 4(a')^2c^2\theta, \quad D_\beta = 4p^2r^2\theta$$

where  $a = ja'$  and  $p = jp'$ . This implies that  $D_{\alpha+\beta} > D_\alpha, D_\beta$ .

(4) If  $GCM(a, b, p, q, \theta) = l > 1$ , then we see that

$$D_{\alpha+\beta} = 4(a')^2(p')^2(p'c + a'r)^2\theta, \quad D_\alpha = 4(a')^2c^2\theta, \quad D_\beta = 4(p')^2r^2\theta$$

where  $a = la'$  and  $p = lp'$ . This implies that  $D_{\alpha+\beta} > D_\alpha, D_\beta$ .

It is clear that  $D_\alpha < 4a^2c^2\theta$ ,  $D_\beta < 4p^2r^2\theta$  if  $GCM(a, b, \theta) > 1$ ,  $GCM(p, q, \theta) > 1$ . Then we complete this lemma.  $\square$

We give the last lemma to complete Theorem 7.1. We show that if  $(x, y, x^*, y^*) \in \overline{\mathbb{X}}$ , then the sequence  $(\overline{T}^k(x, y, x^*, y^*) : k \geq 0)$  is purely periodic.

**Lemma 7.11.** *Suppose iteration by  $T$  of  $(x, y) \in \mathbb{X}$  does not stop. Then the sequence  $(\overline{T}^k(x, y, x^*, y^*) : k \geq 0)$  is purely periodic if  $x$  and  $y$  are in the same quadratic extension of  $\mathbb{Q}$  and  $(x, y, x^*, y^*) \in \overline{\mathbb{X}}$ , where  $x^*$  denotes the algebraic conjugate of  $x$ .*

*Proof.* If  $x$  and  $y$  are in the same quadratic extension of  $\mathbb{Q}$  and  $(x, y, x^*, y^*) \in \overline{\mathbb{X}}$ , then we see that  $x + y$  is equivalent to  $x_k + y_k$ ,  $k \geq 1$  w.r.t the negative slope algorithm from (6.1) and (6.6). It implies that  $D_{x+y}$  is equal to  $D_{x_k+y_k}$  by Lemma 7.8. From Lemma 7.10,  $D_{x_k}$  and  $D_{y_k}$  are bounded by  $D_{x+y}$  for all  $k \geq 1$ . This implies that the cardinality of  $(x_k, y_k)$  for  $k \geq 0$  is finite from Lemma 7.9. Since  $\overline{T}$  is bijective on  $\overline{\mathbb{X}}$ , there exists  $l \geq 1$  s.t. for any  $k > l$ ,

$$\overline{T}^k(x, y, x^*, y^*) = \overline{T}^{k+l}(x, y, x^*, y^*).$$

Note that  $(x, y, x^*, y^*)$  doesn't converge to the boundary of  $\overline{\mathbb{X}}$ . Indeed, if  $(x^*, y^*) = (z, 0)$  for  $z < 0$ , then we see that

$$\overline{T}(z, 0) = \begin{cases} \left( \frac{1}{1-z} - n, \frac{1-z}{1-z} - m \right) & \text{if } \varepsilon = +1 \\ \left( \frac{0}{z-1} - n, \frac{z}{z-1} - m \right) & \text{if } \varepsilon = -1. \end{cases}$$

From Lemma 6.7, there does not exist  $k_0 > 0$  such that  $\overline{T}^k(z, 0) \in \partial(-\infty, 0)^2$  for  $k \geq k_0$ .

Since  $\overline{T}$  is bijective on  $\overline{\mathbb{X}}$ , we see that

$$\overline{T}^{k-1}(x, y, x^*, y^*) = \overline{T}^{k+l-1}(x, y, x^*, y^*).$$

By induction, we obtain

$$(x, y, x^*, y^*) = \overline{T}^l(x, y, x^*, y^*).$$

This completes the proof of Theorem 7.1.  $\square$

Then we have the following corollary of Theorem 7.1.

**Corollary 7.12.** ([1]) *Suppose iteration by the negative slope algorithm  $T$  of  $(x, y) \in \mathbb{X}$  does not stop. Then  $x$  and  $y$  are in the same quadratic extension of  $\mathbb{Q}$  if and only if the sequence  $(T^k(x, y) : k \geq 0)$  is eventually periodic.*

*Proof.* Suppose iteration by the negative slope algorithm  $T$  of  $(x, y) \in \mathbb{X}$  does not stop and  $x$  and  $y$  are in the same quadratic extension of  $\mathbb{Q}$ . Then from Lemma 7.4, there exists  $N' > 0$  such that  $\bar{T}^{N'}(x, y, x^*, y^*) = (x_{N'}, y_{N'}, (x_{N'})^*, (y_{N'})^*) \in \bar{\mathbb{X}}$ . Therefore we see that the sequence  $(\bar{T}^k(x, y, x^*, y^*) : k \geq N')$  is purely periodic by Theorem 7.1. It implies that the sequence  $(T^k(x, y) : k \geq 0)$  is eventually periodic. Conversely, if the sequence  $(T^k(x, y) : k \geq 0)$  is eventually periodic, then there exists  $N > 0$  such that the sequence  $(T^j(x_N, y_N) : j \geq 0)$  is purely periodic. By Theorem 7.1, we see that  $x_N$  and  $y_N$  are in the same quadratic extension of  $\mathbb{Q}$  and  $(x_N, y_N, (x_N)^*, (y_N)^*)$  is in  $\bar{\mathbb{X}}$ . This is the assertion of this corollary.  $\square$

From next section, we consider the modified negative slope algorithm. This algorithm is introduced in [4]. We show that the modified negative slope algorithm is weak Bernoulli and characterize periodic points of the modified negative slope algorithm.

## 8 Definitions and basic notions of the modified negative slope algorithm

Let's define a map  $S$  on the unit square, which is called the modified negative slope algorithm. Let  $\mathbb{X} = [0, 1]^2 \setminus \{(x, y) \mid x + y = 1\}$ , we define

$$S(x, y) = \begin{cases} \left( \left[ \frac{y}{(x+y)-1} \right] - \frac{y}{(x+y)-1}, \left[ \frac{x}{(x+y)-1} \right] - \frac{x}{(x+y)-1} \right) & \text{if } x + y > 1 \\ \left( \frac{1-y}{1-(x+y)} - \left\lfloor \frac{1-y}{1-(x+y)} \right\rfloor, \frac{1-x}{1-(x+y)} - \left\lfloor \frac{1-x}{1-(x+y)} \right\rfloor \right) & \text{if } x + y < 1. \end{cases}$$

We put

$$n(x, y) = \begin{cases} \left[ \frac{y}{(x+y)-1} \right] - 1 & \text{if } x + y > 1 \\ \left\lfloor \frac{1-y}{1-(x+y)} \right\rfloor & \text{if } x + y < 1, \end{cases}$$

$$m(x, y) = \begin{cases} \left[ \frac{x}{(x+y)-1} \right] - 1 & \text{if } x + y > 1 \\ \left\lfloor \frac{1-x}{1-(x+y)} \right\rfloor & \text{if } x + y < 1, \end{cases}$$

and

$$\varepsilon(x, y) = \begin{cases} -1 & \text{if } x + y > 1 \\ +1 & \text{if } x + y < 1. \end{cases}$$

Then we see that  $n(x, y) \geq 1$ ,  $m(x, y) \geq 1$  for all  $(x, y) \in \mathbb{X}$ .

We put

$$\begin{cases} n_k(x, y) & = & n(T^{k-1}(x, y)) \\ m_k(x, y) & = & m(T^{k-1}(x, y)) \\ \varepsilon_k(x, y) & = & \varepsilon(T^{k-1}(x, y)) \end{cases}$$

for  $k \geq 1$ . Then we have a sequence

$$((\varepsilon_1(x, y), n_1(x, y), m_1(x, y)), (\varepsilon_2(x, y), n_2(x, y), m_2(x, y)), \dots)$$

for each  $(x, y) \in \mathbb{X}$ . In §9, we see that the following fact as Lemma 9.8, that is, if  $(x, y) \neq (x', y') \in \mathbb{X}$ , then there exists  $k \geq 1$  such that

$$(\varepsilon_k(x, y), n_k(x, y), m_k(x, y)) \neq (\varepsilon_k(x', y'), n_k(x', y'), m_k(x', y')). \quad (8.1)$$

Now we introduce the projective representation of  $S$ . We put

$$B_{(+1, n, m)} = \begin{pmatrix} n & n-1 & 1-n \\ m-1 & m & 1-m \\ -1 & -1 & 1 \end{pmatrix}$$

and

$$B_{(-1, n, m)} = \begin{pmatrix} n+1 & n & -(n+1) \\ m & m+1 & -(m+1) \\ 1 & 1 & -1 \end{pmatrix}$$

for  $m, n \geq 1$ . Then we see

$$B_{(+1, n, m)}^{-1} = \begin{pmatrix} 1 & 0 & n-1 \\ 0 & 1 & m-1 \\ 1 & 1 & n+m-1 \end{pmatrix}.$$

and

$$B_{(-1, n, m)}^{-1} = \begin{pmatrix} 0 & -1 & m+1 \\ -1 & 0 & n+1 \\ -1 & -1 & n+m+1 \end{pmatrix}$$

We identify  $(x, y)$  to  $\begin{pmatrix} \alpha x \\ \alpha y \\ \alpha \end{pmatrix}$  for  $\alpha \neq 0$ . Then  $S(x, y)$  is identified to

$$B_{(\varepsilon_1(x, y), n_1(x, y), m_1(x, y))} \begin{pmatrix} x \\ y \\ 1 \end{pmatrix}$$



and its local inverse is given by

$$B_{(\varepsilon_1(x,y), n_1(x,y), m_1(x,y))}^{-1}.$$

In this way, we get a representation of  $(x, y)$  by

$$B_{(\varepsilon_1, n_1, m_1)}^{-1} B_{(\varepsilon_2, n_2, m_2)}^{-1} B_{(\varepsilon_3, n_3, m_3)}^{-1} \cdots .$$

For a given sequence  $((\varepsilon_1, n_1, m_1), (\varepsilon_2, n_2, m_2), \dots, (\varepsilon_k, n_k, m_k))$ , we define a cylinder set of length  $k$  by

$$\begin{aligned} & \langle (\varepsilon_1, n_1, m_1), (\varepsilon_2, n_2, m_2), \dots, (\varepsilon_k, n_k, m_k) \rangle \\ &= \{(x, y) \mid (\varepsilon_i(x, y), n_i(x, y), m_i(x, y)) = (\varepsilon_i, n_i, m_i), 1 \leq i \leq k\}. \end{aligned}$$

For  $(x, y) \in \langle (\varepsilon_1, n_1, m_1), (\varepsilon_2, n_2, m_2), \dots, (\varepsilon_k, n_k, m_k) \rangle$ ,  $S^k(x, y)$  is expressed as

$$B_{(\varepsilon_k, n_k, m_k)} \cdots B_{(\varepsilon_1, n_1, m_1)} \begin{pmatrix} x \\ y \\ 1 \end{pmatrix}.$$

We denote its local inverse

$$B_{(\varepsilon_1, n_1, m_1)}^{-1} \cdots B_{(\varepsilon_k, n_k, m_k)}^{-1}$$

by  $\Psi_{\langle (\varepsilon_1, n_1, m_1), (\varepsilon_2, n_2, m_2), \dots, (\varepsilon_k, n_k, m_k) \rangle}$ .

Since

$$\begin{aligned} & \left\{ \left( 1 - \frac{y}{(x+y)-1}, 1 - \frac{x}{(x+y)-1} \right) : (x, y) \in \mathbb{X}, x+y > 1 \right\} \\ &= \{(\alpha, \beta) : \alpha < 0, \beta < 0\}, \\ & \left\{ \left( \frac{1-y}{1-(x+y)}, \frac{1-x}{1-(x+y)} \right) : (x, y) \in \mathbb{X}, x+y < 1 \right\} \\ &= \{(\alpha, \beta) : \alpha \geq 1, \beta \geq 1\}, \end{aligned}$$

we see that

$$S^l \{(x, y) \in \mathbb{X} : \varepsilon_k(x, y) = \varepsilon_k, n_k(x, y) = n_k, m_k(x, y) = m_k, 1 \leq k \leq l\} = \mathbb{X} \quad \text{a.e.} \quad (8.2)$$

for any  $\{(\varepsilon_k, n_k, m_k), 1 \leq k \leq l\}$ ,  $\varepsilon_k = +1$  or  $-1$ ,  $n_k, m_k \geq 1$ .

Next we denote the notation that iteration by the modified negative slope algorithm  $S$  of  $(x, y) \in \mathbb{X}$  stops.

**Definition 8.1.** We define  $k$ -th iteration by the modified negative slope algorithm  $S$  of  $(x, y) \in \mathbb{X}$  as  $(x_k, y_k) = S^k(x, y)$ . Then we say iteration by the modified negative slope algorithm  $T$  of  $(x, y) \in \mathbb{X}$  stops if there exists  $k_0 \geq 0$  such that  $x_{k_0} = 0$  or  $y_{k_0} = 0$  or  $x_{k_0} + y_{k_0} = 1$ . This implies that iteration by the modified negative slope algorithm  $S$  of  $(x, y) \in \mathbb{X}$  stops if there exists  $k_0 \geq 0$  s.t.  $(x_{k_0}, y_{k_0}) \in \partial\mathbb{X}$ .

From this definition, we get the following propositions.

**Proposition 8.2.** If iteration by the modified negative slope algorithm  $S$  of  $(x, y) \in \mathbb{X}$  stops, then  $(x, y)$  satisfies one of the following equations.

$$\begin{aligned}(p+1)x + py &= q \\ px + (p+1)y &= q \\ px + py &= q\end{aligned}$$

for some integers  $0 \leq q \leq 2p$ .

See Proposition 6.5 for the proof. In the following, we give the sufficient condition for the third equation in Proposition 8.2. Also see Proposition 6.6 for the proof.

**Proposition 8.3.** If  $(x, y) \in \mathbb{X}$  satisfies the following equation

$$px + py = q$$

for any integers  $0 \leq q \leq 2p$ , then there exists  $N > 0$  such that the sequence  $(S^k(x, y) : k \geq 0)$  terminates at  $k = N$  for the negative slope algorithm  $S$ .

**REMARK 8.4.** From [4], we see that for  $n_i, m_i \geq 1, i \geq 1$  and for any sequence  $((\varepsilon_i, n_i, m_i), i \geq 1)$ , there exists  $(x, y) \in \mathbb{X}$  such that  $(\varepsilon_i(x, y), n_i(x, y), m_i(x, y)) = (\varepsilon_i, n_i, m_i)$  unless there exists  $k \geq 1$  such that  $(\varepsilon_i, m_i) = (\pm 1, 1)$  for  $i \geq k$  or  $(\varepsilon_i, n_i) = (\pm 1, 1)$  for all  $i \geq k$ .

## 9 Some ergodic properties of the modified negative slope algorithm

In this section, we show the modified negative slope algorithm is weak Bernoulli by using Yuri's conditions. See [15] for Yuri's conditions for multidimensional maps.

First, we define the set  $R(S)$  by

$$\begin{aligned}R(S) &= \{((\varepsilon_1, n_1, m_1), (\varepsilon_2, n_2, m_2), \dots, (\varepsilon_k, n_k, m_k)) \mid \\ &\quad (\varepsilon_k, n_k, m_k) \neq (\pm 1, 1, 1) \text{ or for } k \geq 2 \\ &\quad (\varepsilon_k, n_k, m_k) = (+1, 1, 1), (\varepsilon_{k-1}, n_{k-1}, m_{k-1}) \neq (+1, 1, 1) \\ &\quad (\varepsilon_k, n_k, m_k) = (-1, 1, 1), (\varepsilon_{k-1}, n_{k-1}, m_{k-1}) \neq (-1, 1, 1)\}.\end{aligned}$$

Then we show that  $R(S)$  satisfies the definition of Rényi cylinders in Lemma 9.7. In the sequel, we simply write  $\Delta_k$  for a cylinder set

$$\langle (\varepsilon_1, n_1, m_1), (\varepsilon_2, n_2, m_2), \dots, (\varepsilon_k, n_k, m_k) \rangle$$

if it is clear in the context. We put

$$\Phi_{\Delta_k} = B_{(\varepsilon_1, n_1, m_1)}^{-1} \cdots B_{(\varepsilon_k, n_k, m_k)}^{-1} = \begin{pmatrix} p_1^{(k)} & p_2^{(k)} & p_3^{(k)} \\ r_1^{(k)} & r_2^{(k)} & r_3^{(k)} \\ q_1^{(k)} & q_2^{(k)} & q_3^{(k)} \end{pmatrix}$$

for any sequence  $((\varepsilon_1, n_1, m_1), (\varepsilon_2, n_2, m_2), \dots, (\varepsilon_k, n_k, m_k))$ ,  $k \geq 1$ .

## 9.1 Some properties for $\Phi_{\Delta_k}$

In the following, we have some lemmas for  $p_i^{(k)}$ ,  $r_i^{(k)}$ ,  $q_i^{(k)}$ ,  $i = 1, 2, 3$ ,  $k \geq 1$ .

**Lemma 9.1.** *For entries of  $\Phi_{\Delta_k}$ , we have*

$$\begin{cases} p_1^{(k)} &= p_2^{(k)} + 1 \\ r_1^{(k)} &= r_2^{(k)} - 1 \\ q_1^{(k)} &= q_2^{(k)}. \end{cases}$$

*Proof.* By simple calculation, we see that

$$B_{(\pm 1, n, m)}^{-1} \begin{pmatrix} 1 \\ -1 \\ 0 \end{pmatrix} = (+1) \begin{pmatrix} 1 \\ -1 \\ 0 \end{pmatrix}.$$

Then we see that

$$B_{(\varepsilon_1, n_1, m_1)}^{-1} \cdots B_{(\varepsilon_k, n_k, m_k)}^{-1} \begin{pmatrix} 1 \\ -1 \\ 0 \end{pmatrix} = (+1) \begin{pmatrix} 1 \\ -1 \\ 0 \end{pmatrix}$$

for  $k \geq 1$ . Therefore, we obtain

$$\begin{pmatrix} p_1^{(k)} - p_2^{(k)} \\ r_1^{(k)} - r_2^{(k)} \\ q_1^{(k)} - q_2^{(k)} \end{pmatrix} = \begin{pmatrix} 1 \\ -1 \\ 0 \end{pmatrix}.$$

□

**Lemma 9.2.** For all  $k \geq 1$ , we have  $q_3^{(k)} > 0$  and  $2q_1^{(k)} + q_3^{(k)} > 0$ .

*Proof.* From the previous lemma, we see that

$$(q_1^{(k)}, q_2^{(k)}, q_3^{(k)}) = \begin{cases} \left( q_1^{(k-1)} + q_3^{(k-1)}, q_2^{(k-1)} + q_3^{(k-1)}, (n_k + m_k - 2)q_1^{(k-1)} + (n_k + m_k - 1)q_3^{(k-1)} \right) & \text{if } \varepsilon_k = +1 \\ \left( -q_2^{(k-1)} - q_3^{(k-1)}, -q_1^{(k-1)} - q_3^{(k-1)}, (n_k + m_k + 2)q_1^{(k-1)} + (n_k + m_k + 1)q_3^{(k-1)} \right) & \text{if } \varepsilon_k = -1. \end{cases}$$

We see that  $q_3^{(1)} > 0$  and  $2q_1^{(1)} + q_3^{(1)} > 0$ . Assume that  $q_3^{(k-1)} > 0$  and  $2q_1^{(k-1)} + q_3^{(k-1)} > 0$  for  $k \geq 2$ . Then from the above relations and Lemma 9.1, we have  $q_3^{(k)} > 0$  and

$$2q_1^{(k)} + q_3^{(k)} = \begin{cases} (n_k + m_k)(q_1^{(k-1)} + q_3^{(k-1)}) + q_3^{(k-1)} & \text{if } \varepsilon_k = +1 \\ (n_k + m_k - 2)(q_1^{(k-1)} + q_3^{(k-1)}) + (2q_1^{(k-1)} + q_3^{(k-1)}) & \text{if } \varepsilon_k = -1 \end{cases} > 0$$

This is the assertion of this lemma. □

We have similar results for  $p_i^{(k)}$  and  $r_i^{(k)}$ ,  $i = 1, 2, 3$ .

**Lemma 9.3.** For  $k \geq 1$ ,  $p_3^{(k)} \geq 0$  and  $2p_1^{(k)} + p_3^{(k)} > 0$ ,  $i = 1, 2$ .

*Proof.* We see that  $p_3^{(1)} \geq 0$  and  $2p_1^{(1)} + p_3^{(1)} > 0$ . Assume that  $p_3^{(k-1)} \geq 0$  and  $2p_1^{(k-1)} + p_3^{(k-1)} > 0$  for  $k \geq 2$ . Then from Lemma 9.1, we have

$$p_3^{(k)} = \begin{cases} (n_k + m_k - 2)(p_1^{(k-1)} + p_3^{(k-1)}) + p_3^{(k-1)} + n - 1 & \text{if } \varepsilon_k = +1 \\ (n_k + m_k)(p_1^{(k-1)} + p_3^{(k-1)}) + (2p_1^{(k-1)} + p_3^{(k-1)}) + m + 1 & \text{if } \varepsilon_k = -1. \end{cases} \geq 0$$

and

$$2p_1^{(k)} + p_3^{(k)} = \begin{cases} (n_k + m_k)(p_1^{(k-1)} + p_3^{(k-1)}) + p_3^{(k-1)} + n & \text{if } \varepsilon_k = +1 \\ (n_k + m_k - 2)(p_1^{(k-1)} + p_3^{(k-1)}) + (2p_1^{(k-1)} + p_3^{(k-1)}) + m & \text{if } \varepsilon_k = -1 \end{cases} > 0$$

This is the assertion of this lemma. □

By the same way, we have  $r_3^{(k)} \geq 0$  and  $2r_i^{(k)} + r_3^{(k)} > 0$  for  $i = 1, 2$ . Moreover, we see that the signs of  $p_i^{(k)}, r_i^{(k)}, q_i^{(k)}, i = 1, 2$  are the same for all  $k \geq 1$

**Lemma 9.4.** *For  $x, y \in \mathbb{X}$ , we have*

$$x + y = \frac{(p_2^{(k)} + r_2^{(k)})(x_k + y_k) + (p_3^{(k)} + r_3^{(k)})}{q_2^{(k)}(x_k + y_k) + q_3^{(k)}},$$

$$(p_2^{(k)} + r_2^{(k)})q_3^{(k)} - (p_3^{(k)} + r_3^{(k)})q_2^{(k)} = -1.$$

*Proof.* By taking a determinant of  $\Phi_{\Delta_k}$ , we have

$$\begin{vmatrix} p_1^{(k)} & p_2^{(k)} & p_3^{(k)} \\ r_1^{(k)} & r_2^{(k)} & r_3^{(k)} \\ q_1^{(k)} & q_2^{(k)} & q_3^{(k)} \end{vmatrix} = p_1^{(k)} \begin{vmatrix} r_2^{(k)} & r_3^{(k)} \\ q_2^{(k)} & q_3^{(k)} \end{vmatrix} - p_2^{(k)} \begin{vmatrix} r_1^{(k)} & r_3^{(k)} \\ q_1^{(k)} & q_3^{(k)} \end{vmatrix} + p_3^{(k)} \begin{vmatrix} r_1^{(k)} & r_2^{(k)} \\ q_1^{(k)} & q_2^{(k)} \end{vmatrix}.$$

From Lemma 2.1, the right hand side is equal to

$$(p_2^{(k)} + 1) \begin{vmatrix} r_2^{(k)} & r_3^{(k)} \\ q_2^{(k)} & q_3^{(k)} \end{vmatrix} - p_2^{(k)} \begin{vmatrix} r_2^{(k)} - 1 & r_3^{(k)} \\ q_1^{(k)} & q_3^{(k)} \end{vmatrix} + p_3^{(k)} \begin{vmatrix} r_2^{(k)} - 1 & r_2^{(k)} \\ q_1^{(k)} & q_2^{(k)} \end{vmatrix}.$$

Since  $\det \Phi_{\Delta_k} = 1$ , we have

$$(r_2^{(k)} q_3^{(k)} - r_3^{(k)} q_2^{(k)}) + (p_2^{(k)} q_3^{(k)} - p_3^{(k)} q_2^{(k)}) = 1. \quad (9.1)$$

Substituting  $p_1^{(k)} = p_2^{(k)} + 1$ ,  $r_1^{(k)} = r_2^{(k)} - 1$  and  $q_1^{(k)} = q_2^{(k)}$  for (1), we see that

$$(r_1^{(k)} q_3^{(k)} - r_3^{(k)} q_1^{(k)}) + (p_1^{(k)} q_3^{(k)} - p_3^{(k)} q_1^{(k)}) = 1. \quad (9.2)$$

From (9.1) and (9.2), we have

$$\frac{p_1^{(k)} + r_1^{(k)}}{q_1^{(k)}} = \frac{p_2^{(k)} + r_2^{(k)}}{q_2^{(k)}} = \frac{p_3^{(k)} + r_3^{(k)}}{q_3^{(k)}} + \frac{1}{q_2^{(k)} q_3^{(k)}}. \quad (9.3)$$

For  $(x, y) \in \mathbb{X}$ , let  $(x_k, y_k) = T^k(x, y)$ ,  $k \geq 1$ . Then we see that

$$\begin{pmatrix} \alpha x \\ \alpha y \\ \alpha \end{pmatrix} = \begin{pmatrix} p_1^{(k)} & p_2^{(k)} & p_3^{(k)} \\ r_1^{(k)} & r_2^{(k)} & r_3^{(k)} \\ q_1^{(k)} & q_2^{(k)} & q_3^{(k)} \end{pmatrix} \begin{pmatrix} x_k \\ y_k \\ 1 \end{pmatrix}$$

for  $\alpha \neq 0$ . Then we obtain

$$x = \frac{p_1^{(k)} x_k + p_2^{(k)} y_k + p_3^{(k)}}{q_1^{(k)} x_k + q_2^{(k)} y_k + q_3^{(k)}}, \quad (9.4)$$

$$y = \frac{r_1^{(k)} x_k + r_2^{(k)} y_k + r_3^{(k)}}{q_1^{(k)} x_k + q_2^{(k)} y_k + q_3^{(k)}}. \quad (9.5)$$

Since  $q_3^{(k)} > 0$  for  $k \geq 1$ , the denominators of the above two equations are not equal to 0. From  $p_1^{(k)} = p_2^{(k)} + 1$ ,  $r_1^{(k)} = r_2^{(k)} - 1$  and  $q_1^{(k)} = q_2^{(k)}$ , we have

$$x + y = \frac{(p_2^{(k)} + r_2^{(k)})(x_k + y_k) + (p_3^{(k)} + r_3^{(k)})}{q_2^{(k)}(x_k + y_k) + q_3^{(k)}}. \quad (9.6)$$

This is the assertion of this lemma.  $\square$

**Lemma 9.5.** For  $k \geq 1$ , we have

$$\max \left\{ \frac{p_2^{(k)} + r_2^{(k)}}{q_2^{(k)}}, \frac{p_3^{(k)} + r_3^{(k)}}{q_3^{(k)}} \right\} < 2$$

*Proof.* From (9.5), we see that

$$\begin{cases} \frac{p_3^{(k)} + r_3^{(k)}}{q_3^{(k)}} < \frac{p_2^{(k)} + r_2^{(k)}}{q_2^{(k)}} & \text{if } q_2^{(k)} > 0 \\ \frac{p_2^{(k)} + r_2^{(k)}}{q_2^{(k)}} < \frac{p_3^{(k)} + r_3^{(k)}}{q_3^{(k)}} & \text{if } q_2^{(k)} < 0 \end{cases}$$

(I) Suppose that  $q_2^{(k-1)} > 0$  and  $\frac{p_2^{(k-1)} + r_2^{(k-1)}}{q_2^{(k-1)}} < 2$  for  $k \geq 2$ , then we have following.

(i) If  $\varepsilon_k = +1$ , that is  $q_2^{(k)} > 0$ , then we have

$$\frac{p_2^{(k)} + r_2^{(k)}}{q_2^{(k)}} = \frac{p_2^{(k-1)} + r_2^{(k-1)} + p_3^{(k-1)} + r_3^{(k-1)}}{q_2^{(k-1)} + q_3^{(k-1)}}$$

Since

$$\Phi_{\Delta_{k-1}}(0, 1) = \left( \frac{p_2^{(k-1)} + p_3^{(k-1)}}{q_2^{(k-1)} + q_3^{(k-1)}}, \frac{r_2^{(k-1)} + r_3^{(k-1)}}{q_2^{(k-1)} + q_3^{(k-1)}} \right),$$

this implies that

$$\frac{p_2^{(k)} + r_2^{(k)}}{q_2^{(k)}} < 2.$$

(ii) If  $\varepsilon_k = -1$ , that is  $q_2^{(k)} < 0$ , then we have

$$\begin{aligned} \frac{p_3^{(k)} + r_3^{(k)}}{q_3^{(k)}} &= \frac{-2(p_2^{(k-1)} + r_2^{(k-1)}) + (n_k + m_k + 1)(p_3^{(k-1)} + r_3^{(k-1)})}{-2q_2^{(k-1)} + (n_k + m_k + 1)q_3^{(k-1)}} \\ &= \frac{p_3^{(k-1)} + r_3^{(k-1)}}{q_3^{(k-1)}} - \frac{2}{q_3^{(k-1)}(-2q_2^{(k)} + (n_k + m_k + 1)q_3^{(k-1)})} \\ &< \frac{p_3^{(k-1)} + r_3^{(k-1)}}{q_3^{(k-1)}} < 2 \end{aligned}$$

from (9.5).

(II) Suppose that  $q_2^{(k-1)} < 0$  and  $\frac{p_3^{(k-1)} + r_3^{(k-1)}}{q_3^{(k-1)}} < 2$  for  $k \geq 2$ , then we have following.

(i) If  $\varepsilon_k = +1$ , that is  $q_2^{(k)} > 0$ , then we have

$$\frac{p_2^{(k)} + r_2^{(k)}}{q_2^{(k)}} = \frac{p_2^{(k-1)} + r_2^{(k-1)} + p_3^{(k-1)} + r_3^{(k-1)}}{q_2^{(k-1)} + q_3^{(k-1)}}$$

Since

$$\Phi_{\Delta_{k-1}}(0, 1) = \left( \frac{p_2^{(k-1)} + p_3^{(k-1)}}{q_2^{(k-1)} + q_3^{(k-1)}}, \frac{r_2^{(k-1)} + r_3^{(k-1)}}{q_2^{(k-1)} + q_3^{(k-1)}} \right),$$

this implies that

$$\frac{p_2^{(k)} + r_2^{(k)}}{q_2^{(k)}} < 2.$$

(ii) If  $\varepsilon_k = -1$ , that is  $q_2^{(k)} < 0$ , then we have

$$\begin{aligned} \frac{p_3^{(k)} + r_3^{(k)}}{q_3^{(k)}} &= \frac{p_3^{(k-1)} + r_3^{(k-1)}}{q_3^{(k-1)}} - \frac{2}{q_3^{(k)}(-2q_2^{(k)} + (n_k + m_k + 1)q_3^{(k-1)})} \\ &< \frac{p_3^{(k-1)} + r_3^{(k-1)}}{q_3^{(k-1)}} < 2 \end{aligned}$$

from (9.5). This is the assertion of this lemma.  $\square$

**Lemma 9.6.** For any sequence  $((\varepsilon_1, n_1, m_1), (\varepsilon_2, n_2, m_2), \dots, (\varepsilon_k, n_k, m_k))$ ,  $\varepsilon_i = \pm 1$ ,  $n_i, m_i \geq 1$ ,  $1 \leq i \leq k$ , we see

- (i)  $S^k(\Delta_k) = \mathbb{X}$ ,
- (ii)

$$|\det D\Phi_{\Delta_k}(x, y)| = \frac{1}{(q_1^{(k)}x + q_2^{(k)}y + q_3^{(k)})^3}.$$

*Proof.* It is an easy consequence of induction and calculation, respectively, see also F. Schweiger[13], proposition 2 for (ii).  $\square$

From these lemmas, we can show that  $R(S)$  is the set of Rényi cylinders.

**Lemma 9.7.** If  $\langle (\varepsilon_1, n_1, m_1), (\varepsilon_2, n_2, m_2), \dots, (\varepsilon_k, n_k, m_k) \rangle \in R(S)$ , then

$$\sup_{(x,y) \in \mathbb{X}} |\det D\Phi_{\Delta_k}(x, y)| \leq 8^3 \inf_{(x,y) \in \mathbb{X}} |\det D\Phi_{\Delta_k}(x, y)|.$$

Therefore,  $R(S)$  is the set of Rényi cylinders.

*Proof.*

(Case 1)

For  $\Delta_k = \langle (\varepsilon_1, n_1, m_1), (\varepsilon_2, n_2, m_2), \dots, (\varepsilon_k, n_k, m_k) \rangle$ , assume that  $(\varepsilon_k, n_k, m_k) \neq (\pm 1, 1, 1)$ , then we see that

$$\frac{\sup_{(x,y) \in \mathbb{X}} |\det D\Phi_{\Delta_k}(x, y)|}{\inf_{(x,y) \in \mathbb{X}} |\det D\Phi_{\Delta_k}(x, y)|} = \begin{cases} \left( \frac{2q_1^{(k)} + q_3^{(k)}}{q_3^{(k)}} \right)^3 & \text{if } q_1^{(k)} > 0 \\ \left( \frac{q_3^{(k)}}{2q_1^{(k)} + q_3^{(k)}} \right)^3 & \text{if } q_1^{(k)} < 0. \end{cases}$$

By the way, if  $q_1^{(k)} > 0$  and  $\varepsilon_k = -1$  then we see that

$$0 < q_1^{(k)} = -q_1^{(k-1)} - q_3^{(k-1)}.$$

This is the contradiction to Lemma 9.2. Then it implies  $\varepsilon_k = +1$  for  $q_1^{(k)} > 0$ . So we have

$$q_3^{(k)} - q_1^{(k)} = (n_k + m_k - 3)(q_1^{(k-1)} + q_3^{(k-1)}) + q_3^{(k-1)} > 0.$$

From this fact, we obtain

$$\frac{2q_1^{(k)} + q_3^{(k)}}{q_3^{(k)}} < \frac{3q_3^{(k)}}{q_3^{(k)}} = 3$$



Similarly, if  $q_1^{(k)} < 0$  and  $\varepsilon_k = +1$  then we see that

$$0 > q_1^{(k)} = q_1^{(k-1)} + q_3^{(k-1)}.$$

This is the contradiction to Lemma 9.2. Then it implies  $\varepsilon_k = -1$  for  $q_1^{(k)} < 0$ . So we see that

$$\begin{aligned} \frac{q_3^{(k)}}{2q_1^{(k)} + q_3^{(k)}} &= \frac{(n_k + m_k + 2)q_1^{(k-1)} + (n_k + m_k + 1)q_3^{(k-1)}}{(n_k + m_k)q_1^{(k-1)} + (n_k + m_k - 1)q_3^{(k-1)}} \\ &= 1 + \frac{2q_1^{(k-1)} + 2q_3^{(k-1)}}{(n_k + m_k - 2)(q_1^{(k-1)} + q_3^{(k-1)}) + (2q_1^{(k-1)} + q_3^{(k-1)})} \\ &< 1 + \frac{2q_1^{(k-1)} + 2q_3^{(k-1)}}{3q_1^{(k-1)} + 2q_3^{(k-1)}}. \end{aligned}$$

From Lemma 9.2, we obtain

$$\frac{2q_1^{(k-1)} + 2q_3^{(k-1)}}{3q_1^{(k-1)} + 2q_3^{(k-1)}} < \begin{cases} 1 & \text{if } q_1^{(k-1)} > 0 \\ \frac{2q_3^{(k-1)}}{\frac{1}{2}q_3^{(k-1)}} = 5 & \text{if } q_1^{(k-1)} < 0. \end{cases}$$

(Case 2)

For  $\Delta_k = \langle (\varepsilon_1, n_1, m_1), (\varepsilon_2, n_2, m_2), \dots, (\varepsilon_k, n_k, m_k) \rangle$ , assume  $(\varepsilon_k, n_k, m_k) = (+1, 1, 1)$  and  $(\varepsilon_{k-1}, n_{k-1}, m_{k-1}) \neq (+1, 1, 1)$ , then we see the following two cases for  $(\varepsilon_{k-1}, n_{k-1}, m_{k-1}) \neq (+1, 1, 1)$ .

(i) If  $\varepsilon_{k-1} = +1$  and  $n_{k-1} + m_{k-1} \geq 3$ , then we have

$$(q_1^{(k-1)}, q_3^{(k-1)}) = (q_1^{(k-2)} + q_3^{(k-2)}, (n_{k-1} + m_{k-1} - 2)q_1^{(k-2)} + (n_{k-1} + m_{k-1} - 1)q_3^{(k-2)}).$$

(ii) If  $\varepsilon_{k-1} = -1$ , then we have

$$(q_1^{(k-1)}, q_3^{(k-1)}) = (-q_1^{(k-2)} - q_3^{(k-2)}, (n_{k-1} + m_{k-1} + 2)q_1^{(k-2)} + (n_{k-1} + m_{k-1} + 1)q_3^{(k-2)}).$$

Thus we see that  $q_1^{(k)} = q_1^{(k-1)} + q_3^{(k-1)} > 0$  and  $q_3^{(k)} = q_3^{(k-1)} > 0$  for both cases. So we have

$$\frac{\sup_{(x,y) \in \mathbb{X}} |\det D\Phi_{\Delta_k}(x,y)|}{\inf_{(x,y) \in \mathbb{X}} |\det D\Phi_{\Delta_k}(x,y)|} = \left( \frac{2q_1^{(k)} + q_3^{(k)}}{q_3^{(k)}} \right)^3 = \left( \frac{2q_1^{(k-1)} + 3q_3^{(k-1)}}{q_3^{(k-1)}} \right)^3 < 5^3.$$

(Case 3)

For  $\Delta_k = \langle (\varepsilon_1, n_1, m_1), (\varepsilon_2, n_2, m_2), \dots, (\varepsilon_k, n_k, m_k) \rangle$ , assume  $(\varepsilon_k, n_k, m_k) = (-1, 1, 1)$

and  $(\varepsilon_{k-1}, n_{k-1}, m_{k-1}) \neq (-1, 1, 1)$ , then we see the following two cases for  $(\varepsilon_{k-1}, n_{k-1}, m_{k-1}) \neq (-1, 1, 1)$ .

(i) If  $\varepsilon_{k-1} = -1$  and  $n_{k-1} + m_{k-1} \geq 3$ , then we have

$$\begin{aligned} (q_1^{(k-1)}, q_3^{(k-1)}) &= (-q_1^{(k-2)} - q_3^{(k-2)}, (n_{k-1} + m_{k-1} + 2)q_1^{(k-2)} + (n_{k-1} + m_{k-1} + 1)q_3^{(k-2)}), \\ (q_1^{(k)}, q_3^{(k)}) &= (-q_1^{(k-1)} - q_3^{(k-1)}, 4q_1^{(k-1)} + 3q_3^{(k-1)}). \end{aligned}$$

Since  $q_1^{(k-1)} < 0$  and  $q_3^{(k-1)} < 0$ , we obtain

$$\begin{aligned} \frac{\sup_{(x,y) \in \mathbb{X}} |\det D\Phi_{\Delta_k}(x, y)|}{\inf_{(x,y) \in \mathbb{X}} |\det D\Phi_{\Delta_k}(x, y)|} &= \left( \frac{q_3^{(k)}}{2q_1^{(k)} + q_3^{(k)}} \right)^3 = \left( \frac{4q_1^{(k-1)} + 3q_3^{(k-1)}}{2q_1^{(k-1)} + q_3^{(k-1)}} \right)^3 \\ &= \left( 2 + \frac{q_3^{(k-1)}}{2q_1^{(k-1)} + q_3^{(k-1)}} \right)^3 \\ &= \left( 2 + \frac{(n_{k-1} + m_{k-1} + 2)q_1^{(k-2)} + (n_{k-1} + m_{k-1} + 1)q_3^{(k-2)}}{(n_{k-1} + m_{k-1})q_1^{(k-2)} + (n_{k-1} + m_{k-1} - 1)q_3^{(k-2)}} \right)^3 \\ &< \left( 3 + \frac{2q_1^{(k-2)} + 2q_3^{(k-2)}}{3q_1^{(k-2)} + 2q_3^{(k-2)}} \right)^3. \end{aligned}$$

From Lemma 9.2, we obtain

$$\frac{2q_1^{(k-2)} + 2q_3^{(k-2)}}{3q_1^{(k-2)} + 2q_3^{(k-2)}} < \begin{cases} 1 & \text{if } q_1^{(k-2)} > 0 \\ \frac{2q_3^{(k-2)}}{\frac{1}{2}q_3^{(k-2)}} = 5 & \text{if } q_1^{(k-2)} < 0. \end{cases}$$

(ii) If  $\varepsilon_{k-1} = +1$ , then we have

$$\begin{aligned} (q_1^{(k-1)}, q_3^{(k-1)}) &= (q_1^{(k-2)} + q_3^{(k-2)}, (n_{k-1} + m_{k-1} - 2)q_1^{(k-2)} + (n_{k-1} + m_{k-1} - 1)q_3^{(k-2)}), \\ (q_1^{(k)}, q_3^{(k)}) &= (-q_1^{(k-1)} - q_3^{(k-1)}, 4q_1^{(k-1)} + 3q_3^{(k-1)}). \end{aligned}$$

Since  $q_1^{(k-1)} > 0$  and  $q_3^{(k-1)} < 0$ , we obtain

$$\begin{aligned}
\frac{\sup_{(x,y) \in \mathbb{X}} |\det D\Phi_{\Delta_k}(x,y)|}{\inf_{(x,y) \in \mathbb{X}} |\det D\Phi_{\Delta_k}(x,y)|} &= \left( \frac{q_3^{(k)}}{2q_1^{(k)} + q_3^{(k)}} \right)^3 = \left( \frac{4q_1^{(k-1)} + 3q_3^{(k-1)}}{2q_1^{(k-1)} + q_3^{(k-1)}} \right)^3 \\
&< \left( 2 + \frac{q_3^{(k-1)}}{2q_1^{(k-1)} + q_3^{(k-1)}} \right)^3 \\
&< 3^3.
\end{aligned}$$

Then we complete this lemma. □

## 9.2 Weak Bernoulli properties of the modified negative slope algorithm

Now we will show that the modified negative slope algorithm is weak Bernoulli by Yuri's conditions. First let's define the following:

$$\begin{aligned}
\mathcal{D}_k &= \{ \langle (\varepsilon_1, n_1, m_1), (\varepsilon_2, n_2, m_2), \dots, (\varepsilon_k, n_k, m_k) \rangle \mid \\
&\quad \langle (\varepsilon_1, n_1, m_1), (\varepsilon_2, n_2, m_2), \dots, (\varepsilon_i, n_i, m_i) \rangle \notin R(S) \text{ for } 1 \leq i \leq k \},
\end{aligned}$$

$$\mathbf{D}_k = \bigcup_{\Delta_k \in \mathcal{D}_k} \Delta_k,$$

$$\begin{aligned}
\mathcal{B}_k &= \{ \langle (\varepsilon_1, n_1, m_1), (\varepsilon_2, n_2, m_2), \dots, (\varepsilon_k, n_k, m_k) \rangle \in R(S) \mid \\
&\quad \langle (\varepsilon_1, n_1, m_1), (\varepsilon_2, n_2, m_2), \dots, (\varepsilon_{k-1}, n_{k-1}, m_{k-1}) \rangle \in \mathcal{D}_{k-1} \},
\end{aligned}$$

and

$$\mathbf{B}_k = \bigcup_{\Delta_k \in \mathcal{B}_k} \Delta_k.$$

It is easy to see that

$$\mathcal{D}_k = \{ \langle \underbrace{(+1, 1, 1), \dots, (+1, 1, 1)}_{k \text{ times}}, \underbrace{(-1, 1, 1), \dots, (-1, 1, 1)}_{k \text{ times}} \rangle \}.$$

From Lemma 9.6 (i) and Lemma 9.7, they imply that the modified negative slope algorithm satisfies (C.2) and (C.3) of Yuri's conditions [15]. We check (C.1) and (C.4) of Yuri's conditions as follows.

**Lemma 9.8.** (C.1) For any  $(x, y) \neq (x', y') \in \mathbb{X}$ , there exists  $n \geq 0$  such that  $S^n(x, y)$  and  $S^n(x', y')$  are not the same element in a partition of  $\mathbb{X}$ .

*Proof.* It is easy to see that

$$\left( \frac{p_3^{(k)}}{q_3^{(k)}}, \frac{r_3^{(k)}}{q_3^{(k)}} \right), \quad \left( \frac{p_1^{(k)} + p_3^{(k)}}{q_1^{(k)} + q_3^{(k)}}, \frac{r_1^{(k)} + r_3^{(k)}}{q_1^{(k)} + q_3^{(k)}} \right), \quad \left( \frac{p_2^{(k)} + p_3^{(k)}}{q_2^{(k)} + q_3^{(k)}}, \frac{r_2^{(k)} + r_3^{(k)}}{q_2^{(k)} + q_3^{(k)}} \right),$$

and

$$\left( \frac{p_1^{(k)} + p_2^{(k)} + p_3^{(k)}}{q_1^{(k)} + q_2^{(k)} + q_3^{(k)}}, \frac{r_1^{(k)} + r_2^{(k)} + r_3^{(k)}}{q_1^{(k)} + q_2^{(k)} + q_3^{(k)}} \right)$$

are  $\Phi_{\Delta_k}(0, 0)$ ,  $\Phi_{\Delta_k}(1, 0)$ ,  $\Phi_{\Delta_k}(0, 1)$ , and  $\Phi_{\Delta_k}(1, 1)$ , respectively. Then we show that the diameter of  $\langle (\varepsilon_1, n_1, m_1), (\varepsilon_2, n_2, m_2), \dots, (\varepsilon_k, n_k, m_k) \rangle$  is bounded by the distance between  $\Phi_{\Delta_k}(0, 1)$  and  $\Phi_{\Delta_k}(1, 0)$  as follows.

Let  $l$  be the line that passes  $\Phi_{\Delta_k}(0, 1)$  and  $\Phi_{\Delta_k}(1, 0)$ , then we see that

$$l : (q_1^{(k)} + q_3^{(k)})(x + y) - ((p_1^{(k)} + p_3^{(k)}) + (r_1^{(k)} + r_3^{(k)})) = 0.$$

Let  $d(k, x, y)$  be the distance between  $\Phi_{\Delta_k}(0, 1)$  and  $\Phi_{\Delta_k}(1, 0)$ ,  $h_1(k, x, y)$  and  $h_2(k, x, y)$  be the distances between  $l$  and  $\Phi_{\Delta_k}(0, 1)$ ,  $\Phi_{\Delta_k}(1, 0)$ , respectively. Then we have

$$\begin{aligned} d(k, x, y) &= \sqrt{\left( \frac{p_1^{(k)} + p_3^{(k)}}{q_1^{(k)} + q_3^{(k)}} - \frac{p_2^{(k)} + p_3^{(k)}}{q_2^{(k)} + q_3^{(k)}} \right)^2 + \left( \frac{r_1^{(k)} + r_3^{(k)}}{q_1^{(k)} + q_3^{(k)}} - \frac{r_2^{(k)} + r_3^{(k)}}{q_2^{(k)} + q_3^{(k)}} \right)^2}, \\ h_1(k, x, y) &= \frac{\left| (q_1^{(k)} + q_3^{(k)}) \frac{p_3^{(k)} + r_3^{(k)}}{q_3^{(k)}} - (p_1^{(k)} + p_3^{(k)} + r_1^{(k)} + r_3^{(k)}) \right|}{\sqrt{2}(q_1^{(k)} + q_3^{(k)})}, \\ h_2(k, x, y) &= \frac{\left| (q_1^{(k)} + q_3^{(k)}) \frac{p_1^{(k)} + p_2^{(k)} + p_3^{(k)} + r_1^{(k)} + r_2^{(k)} + r_3^{(k)}}{q_1^{(k)} + q_2^{(k)} + q_3^{(k)}} - (p_1^{(k)} + p_3^{(k)} + r_1^{(k)} + r_3^{(k)}) \right|}{\sqrt{2}(q_1^{(k)} + q_3^{(k)})}. \end{aligned}$$

From Lemma 9.2 and (9.3), (9.4) and (9.5), we obtain

$$\begin{aligned} d(k, x, y) &= \frac{\sqrt{2}}{q_1^{(k)} + q_3^{(k)}}, \\ h_1(k, x, y) &= \frac{1}{\sqrt{2}q_3^{(k)}(q_1^{(k)} + q_3^{(k)})}, \\ h_2(k, x, y) &= \frac{1}{\sqrt{2}(q_1^{(k)} + q_3^{(k)})(q_1^{(k)} + q_2^{(k)} + q_3^{(k)})}. \end{aligned}$$

These imply that the diameter of  $\langle (\varepsilon_1, n_1, m_1), (\varepsilon_2, n_2, m_2), \dots, (\varepsilon_k, n_k, m_k) \rangle$  is bounded by  $d(k, x, y)$ . In the following, we show that  $d(k, x, y)$  is monotone decreasing. Then we complete this lemma.

(i) If  $q_1^{(k-1)} > 0$ , then by Lemma 9.2, we see that

$$\begin{aligned} q_1^{(k)} + q_3^{(k)} &= \begin{cases} (n_k + m_k - 1)q_1^{(k-1)} + (n_k + m_k)q_3^{(k-1)} & \text{if } \varepsilon_k = +1 \\ (n_k + m_k + 1)q_1^{(k-1)} + (n_k + m_k)q_3^{(k-1)} & \text{if } \varepsilon_k = -1 \end{cases} \\ &> q_1^{(k-1)} + q_3^{(k-1)} \quad \text{for } \varepsilon_k = \pm 1. \end{aligned}$$

(ii) If  $q_1^{(k-1)} < 0$ , then by Lemma 9.2, we see that

$$\begin{aligned} q_1^{(k)} + q_3^{(k)} &= \begin{cases} (n_k + m_k - 1)(q_1^{(k-1)} + q_3^{(k-1)}) + q_3^{(k-1)} & \text{if } \varepsilon_k = +1 \\ (n_k + m_k - 1)(q_1^{(k-1)} + q_3^{(k-1)}) + (2q_1^{(k-1)} + q_3^{(k-1)}) & \text{if } \varepsilon_k = -1 \end{cases} \\ &> q_1^{(k-1)} + q_3^{(k-1)} \quad \text{for } \varepsilon_k = \pm 1. \end{aligned}$$

This is the assertion of this lemma. □

**Lemma 9.9.** (C.4) *We have*

$$\sum_{k=1}^{\infty} \lambda(\mathbf{D}_k) < \infty$$

where  $\lambda$  denotes the 2-dimensional Lebesgue measure.

*Proof.* It is easy to see that

$$\begin{aligned} &\underbrace{\langle (-1, 1, 1), \dots, (-1, 1, 1) \rangle}_{k \text{ times}} \\ &= \{(x, y) \mid 2 - \frac{k+1}{k}x \leq y < 1, \frac{k}{k+1} - \frac{k}{k+1}x \leq y < 1\}. \end{aligned}$$

From Lemma 4.5, we obtain

$$\lambda(\mathbf{D}_k) = \frac{2}{(k+1)(2k+1)}.$$

This is the assertion of this lemma. □

Then we obtain the following theorem by [15].

**Theorem 9.10.** *There exists an absolutely continuous invariant probability measure  $\eta$  for  $S$  and  $(S, \eta)$  is exact.*

*Proof.* We see that the modified negative slope algorithm satisfies (C.1) - (C.4) of Yuri's conditions. Hence we complete the proof of Theorem 9.10 by [15].  $\square$

**REMARK 9.11.** *The exactness implies not only ergodicity but also mixing of all degrees. In [4], they showed the explicit form of the density function  $\frac{d\eta}{d\lambda}$ , which we will see in §10, and its ergodicity.*

Next we show the following theorem.

**Theorem 9.12.** *(Rohlin's formula) The entropy  $H_\eta(S)$  of  $(\mathbb{X}, S, \eta)$  is given by*

$$H_\eta(S) = \int_{\mathbb{X}} \log |\det DS| d\eta.$$

In the following, we show (C.5)–(C.8) of Yuri's conditions, which imply this theorem.

**Lemma 9.13.** (C.5)

$$W_k = \sum_{l=0}^{\infty} \sum_{\Delta_l \in \mathcal{D}_l} \left( \sup_{(x,y) \in (\cup_{j=1}^k \mathbf{B}_j)} |\det D\Phi_{\Delta_l}(x,y)| \right) < \infty.$$

*Proof.* It is easy to see that

$$\det D\Phi_{\Delta_l}(x,y) = \frac{1}{(-lx - ly + 2l + 1)^3}$$

for  $\Delta_l = \langle (-1, 1, 1), \dots, (-1, 1, 1) \rangle$ . Then we complete this lemma from Lemma 4.7.  $\square$

**Lemma 9.14.** (C.6)

$$\#\mathcal{D}_1 = 2.$$

*Proof.* This is obvious.  $\square$

**Lemma 9.15.** (C.7) *We have*

$$\frac{\sup_{(x,y) \in \mathbb{X}} |\det D\Phi_{\Delta_k}(x,y)|}{\inf_{(x,y) \in \mathbb{X}} |\det D\Phi_{\Delta_k}(x,y)|} = \mathcal{O}(k^3)$$

for  $\Delta_k = \{ \underbrace{\langle (+1, 1, 1), \dots, (+1, 1, 1) \rangle}_{k \text{ times}}, \underbrace{\langle (-1, 1, 1), \dots, (-1, 1, 1) \rangle}_{k \text{ times}} \}$ .

*Proof.* These follow from Lemma 4.9 and Lemma 9.13. □

**Lemma 9.16.** (C.8) *The function  $\log |\det DS|$  is integrable with respect to  $\lambda$ .*

*Proof.* We can complete this lemma by Lemma 4.10. □

Then we finish the proof of the Theorem 9.12 by [15].

In the following, we show that the modified negative slope algorithm is weak Bernoulli.

**Theorem 9.17.** *The modified negative slope algorithm with the absolutely continuous invariant probability measure  $\eta$  is weak Bernoulli.*

To prove this theorem, we show (C.4)\* and (C.9) of Yuri's conditions.

**Lemma 9.18.** (C.4)\*

$$\sum_{k=1}^{\infty} \lambda(\mathbf{D}_k) \cdot \log k < \infty.$$

*Proof.* Since we have  $\lambda(\mathbf{D}_k) = \frac{2}{(k+1)(2k+1)}$  from the proof of Lemma 9.9. This is the assertion of this lemma. □

**Lemma 9.19.** (C.9) *If  $\langle (\varepsilon_1, n_1, m_1), (\varepsilon_2, n_2, m_2), \dots, (\varepsilon_k, n_k, m_k) \rangle \in \mathcal{D}_k^c$  and  $\langle (\varepsilon_2, n_2, m_2), \dots, (\varepsilon_k, n_k, m_k) \rangle \in \mathcal{D}_{k-1}$ , then we have  $\langle (\varepsilon_1, n_1, m_1) \rangle \in \mathbf{B}_1$ , that is,  $(\varepsilon_1, n_1, m_1) \neq (\pm 1, 1, 1)$ .*

*Proof.* It is easy to see from the definitions of  $\mathcal{D}_k$  and  $\mathcal{B}_k$ . □

Since  $S$  satisfies (C.1)–(C.9) with (C.4)\*, it implies the assertion of Theorem 9.17 by [15].

## 10 Absolutely continuous invariant measure of the modified negative slope algorithm

In [4], the density function of the absolutely continuous invariant probability measure was given as follows.

$$\frac{d\eta}{d\lambda} = \frac{1}{4 \log 2} \frac{1}{(x+y)(2-x-y)}.$$

We see this formula by checking Kuzmin's equation

$$f(x, y) = \sum_{\varepsilon=\pm 1, n, m \geq 1} f(\Phi_{(\varepsilon, n, m)}(x, y)) |\det \Phi_{(\varepsilon, n, m)}(x, y)|$$

where  $f(x, y) = \frac{1}{(x+y)(2-x-y)}$ .

In this section, we give the same result by a different way, that is called a “natural extension method”. This method was originally started by [10] for a class of continued fraction algorithms. Let  $\bar{\mathbb{X}} = \mathbb{X} \times \{(-\infty, 0)^2 \cup (1, \infty)^2\}$ . For  $(x, y, z, w) \in \bar{\mathbb{X}}$ , we define a map  $\bar{S}$  on  $\bar{\mathbb{X}}$  by

$$\bar{S}(x, y, z, w) = \begin{cases} \left( n'(x, y) - \frac{y}{(x+y)-1}, m'(x, y) - \frac{x}{(x+y)-1}, n'(x, y) - \frac{w}{(z+w)-1}, m'(x, y) - \frac{z}{(z+w)-1} \right) & \text{if } x + y > 1 \\ \left( \frac{1-y}{1-(x+y)} - n(x, y), \frac{1-x}{1-(x+y)} - m(x, y), \frac{1-w}{1-(z+w)} - n(x, y), \frac{1-z}{1-(z+w)} - m(x, y) \right) & \text{if } x + y < 1, \end{cases}$$

where  $n'(x, y) = n(x, y) + 1$  and  $m'(x, y) = m(x, y) + 1$ . Then it is easy to see that  $\bar{S}$  is bijective on  $\bar{\mathbb{X}}$  except for the set of 4-dimensional Lebesgue measure 0.

**Proposition 10.1.** *The measure  $\bar{\eta}$  defined by*

$$\frac{d\bar{\eta}}{d\bar{\lambda}} = \frac{1}{|(x+y) - (z+w)|^3}$$

*is an invariant measure for  $\bar{S}$ , where  $\bar{\lambda}$  denotes the 4-dimensional Lebesgue measure.*

*Proof.* We complete this proposition by Proposition 5.1. □

**Corollary 10.2.** *The measure  $\eta$  defined by*

$$\frac{d\eta}{d\lambda} = \frac{1}{4 \log 2} \frac{1}{(x+y)(2-x-y)}$$

*is an invariant probability measure for  $S$ .*

*Proof.* It is easy to see that the projection of  $\bar{\eta}$  to  $\mathbb{X}$  is an invariant measure for  $S$ . Then we have

$$\begin{aligned} & \int_{(-\infty, 0) \times (-\infty, 0)} \frac{1}{|(x+y) - (z+w)|^3} dzdw + \int_{(1, \infty) \times (1, \infty)} \frac{1}{|(x+y) - (z+w)|^3} dzdw \\ &= \frac{1}{(x+y)(2-x-y)}. \end{aligned}$$

This is the assertion of this corollary. □



We can compute the entropy  $H_\eta(S)$  explicitly from Theorem 9.12 and Corollary 10.2.

**Proposition 10.3.**

$$H_\eta(S) = \frac{\pi^2}{8 \log 2}.$$

*Proof.* From Proposition 5.3 and Corollary 10.2, we complete this lemma. □

From this proposition, we obtain the exponential divergence of  $q_3^{(k)}$  as  $k \rightarrow \infty$ .

**Proposition 10.4.**

$$\lim_{k \rightarrow \infty} \frac{1}{k} \log q_3^{(k)} = \frac{\pi^2}{24 \log 2}$$

for  $\lambda$ -a.e.  $(x, y)$ .

*Proof.* From the Shannon-MacMillan-Breiman theorem, we have

$$-\lim_{k \rightarrow \infty} \frac{1}{k} \log \eta(\Delta_k) = \frac{\pi^2}{8 \log 2} \quad \eta\text{-a.e.}$$

where  $\Delta_k$  is defined by  $(\varepsilon_i, n_i, m_i) = (\varepsilon_i(x, y), n_i(x, y), m_i(x, y))$  for  $1 \leq i \leq k$ . We take  $(x, y)$  so that  $h(\bar{S}(x, y, z, w)) \cdot |\det D(\bar{S}(x, y, z, w))| \cdot h^{-1}(x, y, z, w) = 1$  for  $h(x, y, z, w) = d\bar{\eta}/d\bar{\lambda}$  holds. Then we choose a subsequence  $(l_k) : k \geq 1$  by

$$l_1 = \min\{l \geq 1 \mid (\varepsilon_l(x, y), n_l(x, y), m_l(x, y)) \neq (\pm 1, 1, 1)\}$$

and

$$\begin{aligned} l_{k+1} &= \min\{l > l_k \mid (\varepsilon_l(x, y), n_l(x, y), m_l(x, y)) \neq (\pm 1, 1, 1) \\ &\quad \text{or } (\varepsilon_{l_{k+1}}, n_{l_{k+1}}, m_{l_{k+1}}) = (+1, 1, 1), (\varepsilon_{l_k}, n_{l_k}, m_{l_k}) \neq (+1, 1, 1), \\ &\quad (\varepsilon_{l_{k+1}}, n_{l_{k+1}}, m_{l_{k+1}}) = (-1, 1, 1), (\varepsilon_{l_k}, n_{l_k}, m_{l_k}) \neq (-1, 1, 1)\}. \end{aligned}$$

for  $k \geq 1$ , which means that we choose all cylinders  $\Delta_l \in R(S)$ . Since  $\Delta_l$  is bounded away from  $(0, 0)$  and  $(1, 1)$ , there exists a constant  $C_1 > 1$  such that

$$\frac{1}{C_1} \lambda(\Delta_{l_k}) < \eta(\Delta_{l_k}) < C_1 \lambda(\Delta_{l_k}).$$

On the other hand, there exists a constant  $C_2 > 1$  and  $C'_2 > 1$  such that

$$\begin{aligned} \frac{1}{C_2 q_3^{(l)}} &< \lambda(\Delta_l) < \frac{C_2}{q_3^{(l)}} && \text{for } \varepsilon_l = +1 \\ \frac{1}{C'_2(2q_1^{(l)} + q_3^{(l)})} &< \lambda(\Delta_l) < \frac{C'_2}{(2q_1^{(l)} + q_3^{(l)})} && \text{for } \varepsilon_l = -1 \end{aligned}$$

whenever  $\Delta_l \in R(S)$ , see Lemma 9.6. But, if  $\Delta_l \in R(S)$ , we see that  $3|q_1^{(l)}| < q_3^{(l)}$  for  $\varepsilon_l = -1$  from the proof Lemma 9.2. Then there exists a constant  $C_3 > 1$  such that

$$\frac{1}{C_3 q_3^{(l)}} < \lambda(\Delta_l) < \frac{C_3}{q_3^{(l)}}$$

whenever  $\Delta_l \in R(S)$ . Hence we obtain

$$\lim_{k \rightarrow \infty} \frac{1}{l_k} \log q_3^{(l_k)} = \frac{\pi^2}{24 \log 2}$$

for  $\eta$ -a.e.  $(x, y)$ . It is clear that  $q_3^{(k)} = q_3^{(k-1)}$  if  $(\varepsilon_k(x, y), n_k(x, y), m_k(x, y)) = (+1, 1, 1)$  and  $2q_1^{(k)} + q_3^{(k)} = 2q_1^{(k-1)} + q_3^{(k-1)}$  if  $(\varepsilon_k(x, y), n_k(x, y), m_k(x, y)) = (-1, 1, 1)$ . Since the indicator function of  $\langle (\pm 1, 1, 1) \rangle$  is obviously integrable with respect to  $\eta$ ,

$$\lim_{k \rightarrow \infty} \frac{l_k - l_{k-1}}{l_k} = 0$$

for  $\eta$ -a.e.  $(x, y)$ . Hence we have

$$\lim_{l \rightarrow \infty} \frac{1}{l} \log q_3^{(l)} = \frac{\pi^2}{24 \log 2}$$

for  $\eta$ -a.e.  $(x, y)$ , equivalently  $\lambda$ -a.e.  $\square$

## 11 Characterization of periodic points of the modified negative slope algorithm

In the previous section, we define  $\overline{S}$ , the natural extension of the modified negative slope algorithm, in  $\overline{\mathbb{X}} = [0, 1]^2 \times \{(-\infty, 0) \cup (1, \infty)^2\}$ . In this section, we show the following theorem.

**Theorem 11.1.** *Suppose iteration by the modified negative slope algorithm  $S$  of  $(x, y) \in \mathbb{X}$  does not stop. Then the sequence  $(S^k(x, y) : k \geq 0)$  is purely periodic if and only if  $x$  and  $y$  are in the same quadratic extension of  $\mathbb{Q}$  and  $(x, y, x^*, y^*) \in \overline{\mathbb{X}}$  where  $x^*$  denotes the algebraic conjugate of  $x$ .*

### 11.1 Necessary part of Theorem 11.1

We show two lemmas to prove necessary condition of Theorem 11.1.

**Lemma 11.2.** *Suppose iteration by the modified negative slope algorithm  $S$  of  $(x, y) \in \mathbb{X}$  does not stop. Then  $x$  and  $y$  are in the same quadratic extension of  $\mathbb{Q}$  if the sequence  $(S^k(x, y) : k \geq 0)$  is purely periodic.*

*Proof.* Suppose the sequence  $(S^k(x, y) : k \geq 0)$  is purely periodic for  $(x, y) \in \mathbb{X}$  by the modified negative slope algorithm  $S$ , then there exists  $l > 0$  such that  $S^l(x, y) = (x, y)$ . From Lemma 9.4, we see that

$$x + y = \frac{(p_2^{(l)} + r_2^{(l)})(x + y) + (p_3^{(l)} + r_3^{(l)})}{q_2^{(l)}(x + y) + q_3^{(l)}}.$$

Then we have the following quadratic equation with respect to  $(x + y)$ .

$$q_2^{(l)}(x + y)^2 + (q_3^{(l)} - p_2^{(l)} - r_2^{(l)})(x + y) - (p_3^{(l)} + r_3^{(l)}) = 0.$$

Here, we put a function  $g(x + y)$  as follows:

$$g(x + y) = q_2^{(l)}(x + y)^2 + (q_3^{(l)} - p_2^{(l)} - r_2^{(l)})(x + y) - (p_3^{(l)} + r_3^{(l)}).$$

Then we see that  $x^* + y^* < 0$  if  $q_2^{(l)} > 0$  and  $x^* + y^* > 2$  if  $q_2^{(l)} < 0$ . From Lemma 9.5, we see the following.

(I) If  $q_2^{(l)} > 0$ , we see that

$$\begin{aligned} g(0) &= -p_3^{(l)} - r_3^{(l)} < 0, \\ g(2) &= 4q_2^{(l)} + 2q_3^{(l)} - 2(p_2^{(l)} + p_3^{(l)}) - (p_3^{(l)} + r_3^{(l)}) \\ &= 2q_2^{(l)} \left( 2 - \frac{p_2^{(l)} + r_2^{(l)}}{q_2^{(l)}} \right) + q_3^{(l)} \left( 2 - \frac{p_3^{(l)} + r_3^{(l)}}{q_3^{(l)}} \right) > 0. \end{aligned}$$

(II) If  $q_2^{(l)} < 0$ , we see that

$$\begin{aligned} g(0) &= -p_3^{(l)} - r_3^{(l)} < 0, \\ g(2) &= 2q_2^{(l)} \left( 2 - \frac{p_2^{(l)} + r_2^{(l)}}{q_2^{(l)}} \right) + q_3^{(l)} \left( 2 - \frac{p_3^{(l)} + r_3^{(l)}}{q_3^{(l)}} \right). \end{aligned}$$

From (9.3), we have

$$\begin{aligned} g(2) &= 2q_2^{(l)} \left\{ 2 - \left( \frac{p_3^{(l)} + r_3^{(l)}}{q_3^{(l)}} + \frac{1}{q_2^{(l)} q_3^{(l)}} \right) \right\} + q_3^{(l)} \left( 2 - \frac{p_3^{(l)} + r_3^{(l)}}{q_3^{(l)}} \right) \\ &= \frac{1}{q_3^{(l)}} \left\{ \left( 2q_3^{(l)} - (p_3^{(l)} + r_3^{(l)}) \right) (2q_2^{(l)} + q_3^{(l)}) - 2 \right\}. \end{aligned}$$

If  $2q_2^{(l)} + q_3^{(l)} = 1$ , then we have

$$\begin{aligned}\Phi_{\Delta_l}(1, 1) &= \left( \frac{p_1^{(l)} + p_2^{(l)} + p_3^{(l)}}{q_1^{(l)} + q_2^{(l)} + q_3^{(l)}}, \frac{r_1^{(l)} + r_2^{(l)} + r_3^{(l)}}{q_1^{(l)} + q_2^{(l)} + q_3^{(l)}} \right) \\ &= (p_1^{(l)} + p_2^{(l)} + p_3^{(l)}, r_1^{(l)} + r_2^{(l)} + r_3^{(l)}) \\ &\in [0, 1]^2.\end{aligned}$$

It implies that  $2p_2^{(l)} + p_3^{(l)} \leq 0$  from Lemma 9.1. This is the contradiction to Lemma 9.3. Then we have  $(2q_3^{(l)} - (p_3^{(l)} + r_3^{(l)}))(2q_2^{(l)} + q_3^{(l)}) \geq 2$ . Since  $(S^k(x, y) : k \geq 0)$  is purely periodic,  $g(2) \neq 0$ . This implies that  $g(2) > 0$  for  $q_2^{(k)} < 0$ . Note that if  $x + y \in \mathbb{Q}$ , then  $(S^k(x, y) : k \geq 0)$  is not periodic from Proposition 8.2. Thus  $x + y$  is a quadratic irrational number and  $x^* + y^* < 0$  if  $q_2^{(l)} > 0$ ,  $x^* + y^* > 2$  if  $q_2^{(l)} < 0$ . From Lemma 9.1 and Lemma 9.4, we have

$$\begin{aligned}x &= \frac{p_2^{(k)}(x + y) + p_3^{(k)}}{q_2^{(k)}(x + y) + q_3^{(k)} - 1}, \\ y &= \frac{r_2^{(k)}(x + y) + r_3^{(k)}}{q_2^{(k)}(x + y) + q_3^{(k)} + 1}.\end{aligned}$$

This is the assertion of this lemma. □

**Lemma 11.3.** *Let  $\Gamma = \{(z, w) \mid z + w < 0, z + w > 2\}$ . Suppose iteration by the modified negative slope algorithm  $S$  of  $(x, y) \in \mathbb{X}$  does not stop. Then there exists  $k_0 \in \mathbb{N}$  s.t.  $(\bar{S}^k(x, y, z, w) : k > k_0) \in \bar{\mathbb{X}}$  for  $(x, y, z, w) \in \mathbb{X} \times \Gamma$ .*

*Proof.* Let  $\Gamma = \{(z, w) \mid z + w < 0, z + w > 2\}$ . Suppose that  $(z, w) \in \{(-\infty, 0)^2 \cup (1, \infty)^2\}$ ,  $(z', w') \in \Gamma \setminus \{(-\infty, 0)^2 \cup (1, \infty)^2\}$  and  $z + w = z' + w'$  (see Fig.6).

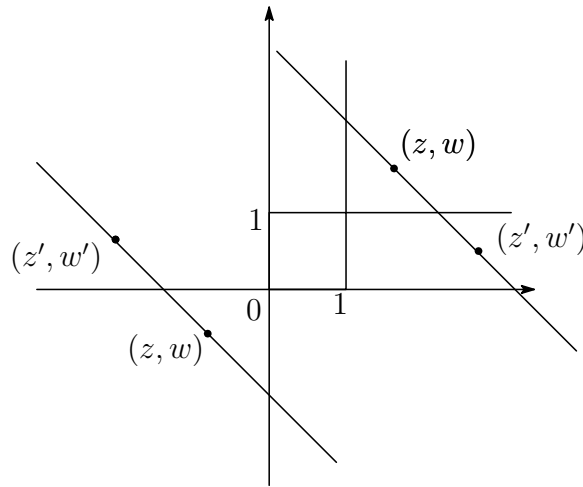

Fig.1

Then we have

$$\begin{aligned}
& |z_1 - z'_1| + |w_1 - w'_1| \\
&= \begin{cases} \left| \frac{1-w}{1-(z+w)} - \frac{1-w'}{1-(z'+w')} \right| + \left| \frac{1-z}{1-(z+w)} - \frac{1-z'}{1-(z'+w')} \right| & \text{if } \varepsilon_1 = +1 \\ \left| \frac{w'}{(w'+z')-1} - \frac{w}{(z+w)-1} \right| + \left| \frac{z'}{(w'+z')-1} - \frac{z}{(z+w)-1} \right| & \text{if } \varepsilon_1 = -1 \end{cases} \\
&= \begin{cases} \frac{1}{|1-(z+w)|} \{|w' - w| + |z' - z|\} & \text{if } \varepsilon_1 = +1 \\ \frac{1}{|(z+w)-1|} \{|w - w'| + |z - z'|\} & \text{if } \varepsilon_1 = -1 \end{cases} \\
&< |z - z'| + |w - w'|.
\end{aligned}$$

By the simple calculation, we see that  $z_k + w_k = z'_k + w'_k$  for  $k \geq 1$ . Then, if iteration by the modified negative slope algorithm  $S$  of  $(x, y) \in \mathbb{X}$  does not stop, there exists  $C > 1$  s.t.

$$|z_k - z'_k| + |w_k - w'_k| < \frac{1}{C^k} (|z - z'| + |w - w'|).$$

Since  $\overline{\mathbb{X}}$  is  $\overline{S}$ -invariant, there exists  $k_0 \in \mathbb{N}$  s.t. for  $k > k_0$ , we have

$$(z'_k, w'_k) \in (-\infty, 0)^2 \cup (1, \infty)^2.$$

Note that the sequence  $((z_k, w_k) : k \geq 1)$  does not converge to the boundary of  $\overline{\mathbb{X}}$  if the sequence  $(S^k(x, y) : k \geq 1)$  does not stop at any finite  $k$ . We denote an image by  $\overline{S}$  of  $(z, w) \in (-\infty, 0)^2 \cup (1, \infty)^2$  as  $\overline{S}(z, w)$  for simplicity.

(I) For  $w < 0$ , we see that

$$\overline{S}(0, w) = \begin{cases} \left( 1 - n, \frac{1}{1-w} - m \right) & \text{if } \varepsilon = +1 \\ \left( n + \frac{1}{w-1}, 1 + m \right) & \text{if } \varepsilon = -1 \end{cases}$$

(II) For  $w > 1$ , we see that

$$\overline{S}(1, w) = \begin{cases} \left( \frac{1}{w} - (1+n), -m \right) & \text{if } \varepsilon = +1 \\ \left( n, (1+m) - \frac{1}{w} \right) & \text{if } \varepsilon = -1 \end{cases}$$

From Remark 8.4, we see that  $((z_k, w_k) : k \geq 1)$  does not converge to the boundary of  $\overline{\mathbb{X}}$  if the sequence  $(S^k(x, y) : k \geq 1)$  does not stop at any finite  $k$ .  $\square$

Now we can complete necessary part of Theorem 11.1.

*Proof.* (necessary part of Theorem 11.1) Suppose the sequence  $(S^k(x, y) : k \geq 0)$  is purely periodic for  $(x, y) \in \mathbb{X}$  by the modified negative slope algorithm  $S$ . Then we see that  $x$  and  $y$  are in the same quadratic extension of  $\mathbb{Q}$  from Lemma 11.2. It is easy to see that  $(\bar{S}^k(x, y, x^*, y^*) : k \geq 0)$  is purely periodic if  $(S^k(x, y) : k \geq 0)$  is purely periodic from Remark 7.5, where  $x^*$  is the algebraic conjugate of  $x$ . Therefore we see that there exists  $N > 0$  such that  $\bar{S}^N(x, y, x^*, y^*) \in \bar{\mathbb{X}}$  from Lemma 11.3. Since  $\bar{\mathbb{X}}$  is  $\bar{S}$ -invariant, we obtain that  $(x, y, x^*, y^*) \in \bar{\mathbb{X}}$ .  $\square$

## 11.2 Sufficient part of Theorem 11.1

We show sufficient part of Theorem 11.1 in this subsection. Suppose  $x$  and  $y$  are in the same quadratic extension of  $\mathbb{Q}$  and  $(x, y, x^*, y^*) \in \bar{\mathbb{X}}$ . Then we show that the number of  $(x, y, x^*, y^*) \in \bar{\mathbb{X}}$  is finite and the orbit of  $(x, y, x^*, y^*)$  by  $\bar{S}$  is purely periodic. We prepare a lemma for proving sufficient condition of Theorem 11.1.

**Lemma 11.4.** *Assume that  $\alpha$  and  $\beta$  are in the same quadratic extension of  $\mathbb{Q}$  and  $(\alpha, \beta, \alpha^*, \beta^*) \in \bar{\mathbb{X}}$ , then  $D_{\alpha+\beta}$  is greater than  $D_\alpha$  and  $D_\beta$ , where  $D_\alpha$  is the discriminant of  $\alpha$ .*

*Proof.* If  $(\alpha, \beta, \alpha^*, \beta^*) \in \mathbb{X} \times (-\infty, 0)^2$ , we obtain the assertion of this lemma from Lemma 7.10. If  $(\alpha, \beta, \alpha^*, \beta^*) \in \mathbb{X} \times (1, \infty)^2$ , we see that

$$\begin{aligned} (\alpha, \alpha^*) &= \left( \frac{-b - c\sqrt{\theta}}{a}, \frac{-b + c\sqrt{\theta}}{a} \right), \quad a, c > 0, \quad GCM(a, b, c) = 1 \\ (\beta, \beta^*) &= \left( \frac{-q - r\sqrt{\theta}}{p}, \frac{-q + r\sqrt{\theta}}{p} \right), \quad p, r > 0, \quad GCM(p, q, r) = 1. \end{aligned}$$

where  $\theta$  does not contain square numbers as factors. By the same calculations as Lemma 7.10, we complete this lemma.  $\square$

We give the last lemma to complete Theorem 11.1. We show that if  $x$  and  $y$  are in the same quadratic extension of  $\mathbb{Q}$  and  $(x, y, x^*, y^*) \in \bar{\mathbb{X}}$ , then the sequence  $(\bar{S}^k(x, y, x^*, y^*) : k \geq 0)$  is purely periodic.

**REMARK 11.5.** *Suppose iteration by  $S$  of  $(x, y) \in \mathbb{X}$  does not stop. Then the sequence  $(\bar{S}^k(x, y, x^*, y^*) : k \geq 0)$  is purely periodic if  $x$  and  $y$  are in the same quadratic extension of  $\mathbb{Q}$  and  $(x, y, x^*, y^*) \in \bar{\mathbb{X}}$ , where  $x^*$  denotes the algebraic conjugate of  $x$ .*

*Proof.* Let  $D_x$  be the discriminant of  $x$ . If  $x$  and  $y$  are in the same quadratic extension of  $\mathbb{Q}$  and  $(x, y, x^*, y^*) \in \bar{\mathbb{X}}$ , then we see that  $x + y$  is equivalent to  $x_k + y_k$ ,  $k \geq 1$  w.r.t the modified negative slope algorithm from (9.1) and (9.6). It implies that  $D_{x+y}$  is equal

to  $D_{x_k+y_k}$  by Lemma 7.8. From Lemma 11.4,  $D_{x_k}$  and  $D_{y_k}$  are bounded by  $D_{x+y}$  for each  $k \geq 1$ . This implies that the cardinality of  $(x_k, y_k)$ ,  $k \geq 1$  is finite from Lemma 7.9. Since  $\overline{\mathbb{X}}$  is  $\overline{S}$ -invariant, there exists  $l \geq 1$  s.t. for any  $k > l$ ,

$$\overline{S}^k(x, y, x^*, y^*) = \overline{S}^{k+l}(x, y, x^*, y^*).$$

Since  $\overline{S}$  is bijective on  $\overline{\mathbb{X}}$ , we see that

$$\overline{S}^{k-1}(x, y, x^*, y^*) = \overline{S}^{k+l-1}(x, y, x^*, y^*).$$

By induction, we get

$$(x, y, x^*, y^*) = \overline{S}^l(x, y, x^*, y^*).$$

This completes this lemma and the proof of Theorem 11.1. □

Then we have the following corollary of Theorem 11.1.

**Corollary 11.6.** *Suppose iteration by the modified negative slope algorithm  $S$  of  $(x, y) \in \mathbb{X}$  does not stop. Then  $x$  and  $y$  are in the same quadratic extension of  $\mathbb{Q}$  if and only if the sequence  $(S^k(x, y) : k \geq 0)$  is eventually periodic.*

See Corollary 7.12 for the proof.

## Acknowledgement

I would like to express my deep gratitude to Professor Hitoshi Nakada for his encouragement and support. I also would like to thank Professor Shunji Ito and Shigeru Tanaka for helpful suggestions and valuable advices. Finally, I would like to thank my parents for their supports.

## Bibliography

- [1] S. Ferenczi, C. Holton, and L. Zamboni, *The structure of three-interval exchange transformations I, an arithmetic study*, Ann. Inst. Fourier (Grenoble) **51** (2001), 861–901.
- [2] S. Ferenczi, C. Holton, and L. Zamboni, *The structure of three-interval exchange transformations II, a combinatorial description of the trajectories*, J. Anal. Math. **89** (2003), 239–276.
- [3] S. Ferenczi, C. Holton, and L. Zamboni, *The structure of three-interval exchange transformations III, ergodic and spectral properties*, J. Anal. Math. **93** (2004), 103–138.
- [4] S. Ferenczi and L. F. C. da Rocha, *A self-dual induction for three-interval exchange transformations*, preprint.
- [5] A. B. Katok, *Theory of dynamical systems and general transformation groups with invariant measure*, J. Sov. Math. **7** (1977), 974–1065.
- [6] M. Keane, *Interval exchange transformations*, Math. Z. **141** (1975), 25–31.
- [7] M. Keane, *Non-ergodic interval exchange transformations*, Isr. J. Math, vol.26, no.2, (1977), 188–196.
- [8] H. B. Keynes and D. Newton, *A "Minimal", Non-uniquely ergodic interval exchange transformation*, Math. Z. **148** (1976), 101–105.
- [9] H. Masur, *Interval exchange transformations and measured foliations*, Ann. Math. **115** (1982), 169–200.
- [10] H. Nakada, *Metrical theory for a class of continued fraction transformations and their natural extensions*, Tokyo J. Math. **4** (1981), 399–426.
- [11] V. I. Oseledets, *On the spectrum of ergodic automorphisms*, Sov. Math. Dokl, **7**, (1966), 776–779.
- [12] G. Rauzy, *Echanges d'intervalles et transformations induites*, Acta. Arith. **34** (1979), 315–328.



- [13] F. Schweiger, *Multidimensional continued fractions*, Oxford Univ. Press, Oxford, (2000).
- [14] W. Veech, *Gauss measures for transformations on the space of interval exchange maps*, *Ann. Math.* **115** (1982), 201-242.
- [15] M. Yuri, *On a Bernoulli property for multi-dimensional mappings with finite range structure*, *Tokyo J. Math.* **9** (1986), 457–485.

Koshiro Ishimura,  
Department of Mathematics, Keio University  
3-14-1 Hiyoshi, Kohoku-ku, Yokohama, Japan  
e-mail: koshiro@math.keio.ac.jp