

A Thesis for the Degree of Ph.D. in Engineering

**A Study on Relay Selection and Routing for
Cooperative and Cognitive Radio Ad Hoc Networks**

February 2013

Graduate School of Science and Technology
Keio University

I-Te Lin

Acknowledgments

I would like to acknowledge my advisor, Prof. Iwao Sasase, for his valuable guidance and constant support throughout my Ph.D. studies at Keio University. I would also like to thank Prof. Naoaki Yamanaka, Prof. Tomoaki Ohtsuki, Prof. Yukitoshi Sanada, Dr. Junji Asada, Prof. Safdar Hussian Bouk, Dr. Alex Fung, Dr. Maduranga Liyanage, and Prof. Sann Maw Maung for their valuable comments on my research work. Moreover, I am grateful to my colleagues in Sasase Laboratory for their assistance, discussions, and suggestions. Finally, I deeply appreciate my parents and friends for their encouragement and understanding.

I-Te Lin

School of Science for Open and Environmental Systems

Graduate School of Science and Technology

Keio University

ABSTRACT

Cooperative transmission has become a promising technique due to its ability to exploit spatial diversity to mitigate the fading effects. Several hybrid relaying schemes have been proposed to adaptively employ different relaying protocols at the relay to improve the system performance. However, how to implement those ideas has not been addressed. Relay selection is another important issue due to its large effects on the system performance. Although several practical relay selection schemes have been proposed, many problems of them still remain unsolved. In the conventional contention-based relay selection scheme, large transmission power of control packets is wasted when the number of relay candidates is large. In addition, the relay is selected without considering the channel condition. On the other hand, cognitive radio has been recognized as a promising technology to improve the spectrum utilization. The spectrum access strategies fall into two categories: overlay access and underlay access. In the overlay access, data are transmitted by using spectrum holes that are not utilized by primary users (PUs). In the underlay access, the primary and cognitive transmissions occur simultaneously at the specified spectrum slot that belongs to PUs.

In wireless ad hoc networks, practical routing protocols have been proposed to reduce the high computational complexity of optimal ones. However, this complexity reduction comes at the cost of the performance degradation. In addition, when practical routing protocols are operated by using the underlay access strategy in a cognitive radio environment, the coexistence of primary and secondary users also degrades the performance. In this dissertation, we propose to integrate cooperative transmission into practical routing protocols to improve the degraded performance. In Chapter 1, first, we explain wireless ad hoc networks briefly. The basic concept, characteristics, applications, challenges, performance metrics, and various routing

protocols are described. Then, we explain cooperative transmissions and networking. The basic concept, the transmission model, relaying protocols, hybrid relaying and single relay selection schemes, and cooperative routing schemes are presented. After that, we explain technologies and routing schemes in cognitive radio communications and networking. Finally, the contribution and outline of this dissertation are described.

In Chapter 2, we propose a practical IEEE 802.11 based cooperative communication scheme in which each relay candidate can adaptively switch its relaying protocol between the Amplify-and-Forward (AF), the Decode-and-Forward (DF), or the no relaying (direct transmission). By exploiting the multicast request-to-send (RTS) and clear-to-send (CTS) packets exchange, each relay candidate first selects the relaying protocol, which minimizes the theoretical bit error rate (BER) based on the estimated channel state information (CSI) of the source-to-relay, the relay-to-destination, and the source-to-destination links. Then, the achievable theoretical BERs are sent back to the source by the BEACON packets in a predefined order. The source selects the relay, which minimizes the theoretical BER to join the cooperative communication. By computer simulations, we investigate the location distribution and the number of times that the AF, the DF, and the no relaying achieve the minimum theoretical BER. It is shown that the proposed scheme outperforms the AF, the DF relaying, and the direct transmission.

In Chapter 3, for cooperative wireless networks, we propose a medium access control (MAC) protocol with distributed relay selection using group-based probabilistic contention and re-participation. The relay with the minimum outage probability is selected in a distributed way. Based on the achievable outage probability, relay candidates are divided into multiple groups, and each relay candidate in a group uses a probability to send the acknowledgement (ACK) packet back to the source to contend for being selected. Each group is defined by a specified range of the outage probability. Relays in a group with lower outage probability range contend earlier. In addition, the relay candidate that does not send the ACK packet in the current time slot is assigned with a higher probability to contend in the next

time slot. Once a relay candidate survives, the contention process is terminated. Thus, transmitting the unnecessary ACK packets for contention is avoided. Simulation results show that compared to the conventional scheme, the proposed one has a better performance in terms of the outage probability, shortens the contention period, and reduces the number of ACK packets for contention.

In Chapter 4, Ad Hoc Routing (AHR) was proposed to replace the minimum-power routing in cluster-based multihop networks since it offers lower implementation complexity. However, this complexity reduction comes at the cost of an increase in the required transmission power. In addition, when the conventional distributed relay selection is applied to implement AHR, another increase in the required transmission power occurs due to the receiver selection error. In this paper, Ad Hoc Cooperative Routing (AHCR) that integrates the cooperative transmission with AHR is presented to reduce the difference between the required transmission power of AHR and that of optimal routing. Besides, Distributed Ad Hoc Cooperative Routing (DAHCR) scheme 1 that combines the cooperative transmission with AHR is proposed to reduce the difference between the required transmission power of distributed ad hoc routing (DAHR) and that of AHR. In DAHCR scheme 1, each node uses the same probability to contend for being selected as the receiver and the relay, and two nodes are randomly selected to perform the cooperative transmission. We then address the problem of DAHCR scheme 1 and propose DAHCR scheme 2. In DAHCR scheme 2, a higher contention probability is assigned to a node with lower required sender transmission power. Besides, the nodes with the minimum and the second minimum required sender transmission power are selected as the receiver and the relay, respectively, to perform the cooperative transmission. Simulation results show that the required transmission power of AHCR and DAHCR scheme 1 is less than that of AHR and DAHR, respectively. In addition, DAHCR scheme 2 further reduces the required transmission power of DAHCR scheme 1. On the other hand, DAHCR scheme 1 increases the complexity by 43% compared to DAHR. Besides, DAHCR scheme 2 increases the complexity by 1.97% compared to DAHCR scheme 1.

In Chapter 5, we propose a primary traffic based routing algorithm with cooperative transmission (PTBR-CT) in cognitive radio ad hoc networks (CRAHN) where the underlay access strategy is used. It enlarges hop transmission distances to reduce the number of cognitive relays on the route from the cognitive source (CS) to the cognitive destination (CD). In each hop, among the cognitive nodes in a specified area depending on whether the primary source (PS) transmits data to the primary destination (PD), the cognitive node that is farthest away from the cognitive relay that sends data is selected as the other one that receives data. However, when the PS is transmitting data to the PD, among the cognitive nodes in a specified area, another cognitive node is also selected and prepared to be the cognitive relay that receives data of cooperative transmission. Cooperative transmission is performed if the PS is still transmitting data to the PD when the cognitive relay that receives data of the next hop transmission is being searched. Simulation results show that PTBMR-CT outperforms conventional primary traffic based farthest neighbor routing (PTBFNR) in terms of the average end-to-end reliability, throughput, required transmission power, and transmission latency.

Chapter 6 concludes this dissertation.

Table of Contents

List of Figures	x
List of Tables	xiii
1 General Introduction	1
1.1 Wireless Ad Hoc Networks	1
1.1.1 Introduction	1
1.1.2 Characteristics	3
1.1.3 Applications	5
1.1.4 Challenges	7
1.1.5 Performance Metrics	9
1.2 Routing Protocols for Wireless Ad Hoc Networks	10
1.2.1 Introduction	10
1.2.2 Proactive Routing Schemes	12
1.2.2.1 Destination-Sequence Distance-Vector Protocol	12
1.2.2.2 Wireless Routing Protocol	13
1.2.3 Reactive Routing Schemes	14
1.2.3.1 Dynamic Source Routing	14
1.2.3.2 Ad Hoc On-Demand Distance Vector Routing	15
1.2.4 Hybrid Routing Schemes	16
1.2.4.1 Zone Routing Protocol	16
1.2.4.2 Cluster-Based Routing Protocols	17
1.2.5 Position-Based Routing Schemes	21
1.3 Cooperative Transmissions and Networking	23
1.3.1 Introduction	23
1.3.2 Transmission Model	25
1.3.3 Fixed Relaying Protocols	26
1.3.3.1 Amplify-and-Forward Relaying Protocol	26
1.3.3.2 Decode-and-Forward Relaying Protocol	27
1.3.4 Adaptive Relaying Protocols	28
1.3.4.1 Selective DF Relaying	29
1.3.4.2 Incremental Relaying	29
1.3.5 Hybrid Relaying Schemes	30
1.3.6 Single Relay Selection Schemes	31
1.3.6.1 HARBINGER	32
1.3.6.2 Timer-Based Single Relay Selection	33
1.3.6.3 Busy-Tone-Based Single Relay Selection	34
1.3.6.4 Contention-Based Single Relay Selection	35
1.3.7 Cooperative Routing Schemes	36
1.4 Cognitive Raio Communications and Networking	38
1.4.1 Introduction	38
1.4.2 Routing Schemes in CRNs	40

1.4.2.1	Routing Schemes with Full Spectrum Knowledge . . .	41
1.4.2.2	Routing Schemes with Local Spectrum Knowledge . . .	43
1.5	Positions, Contributions and Outline of This Dissertation	46
2	Hybrid Relaying Based Cooperative Communication with Semi-Distributed Single Relay Selection	54
2.1	Introduction	54
2.2	Transmission Model	55
2.2.1	Amplify-and-Forward Relaying Protocol	56
2.2.2	Decode-and-Forward Relaying Protocol	57
2.2.3	No Relaying (direct transmission)	58
2.3	Proposed Approach	58
2.3.1	Phase 1: Multicast RTS and CTS Packets Exchange	58
2.3.2	Phase 2: Relaying Protocol Selection	60
2.3.3	Phase 3: Semi-distributed Single Relay Selection	60
2.3.4	Phase 4: Data Transmission	60
2.4	Performance Evaluation	61
2.5	Conclusion	65
3	Cooperative MAC Protocol with Distributed Relay Selection Using Group- Based Probabilistic Contention and Re-Participation	67
3.1	Introduction	67
3.2	System Model	68
3.3	Decode-and-Forward Incremental Relaying Protocol	69
3.4	Protocol Design	71
3.4.1	Source-to-Destination Transmission Phase	71
3.4.2	Relay Selection Phase	73
3.4.3	Relay-to-Destination Transmission Phase	75
3.5	Performance Evaluations	75
3.6	Conclusion	80
4	Distributed Ad Hoc Cooperative Routing in Cluster-Based Multihop Net- works	82
4.1	Introduction	82
4.2	System Model	83
4.2.1	Transmission Model	83
4.2.2	Direct and Cooperative Transmissions	84
4.2.3	Link Analysis	85
4.3	Distributed Ad Hoc Routing (DAHR)	87
4.4	Proposed Routing Schemes	88
4.4.1	Ad Hoc Cooperative Routing (AHCR)	88
4.4.2	Distributed Ad Hoc Cooperative Routing (DAHCR)	89
4.4.2.1	Scheme 1	89
4.4.2.2	Scheme 2	92

4.5	Performance Evaluation	94
4.6	Conclusion	107
5	Primary Traffic Based Cooperative Routing with Preliminary Farthest Relay Selection in Cognitive Radio Ad Hoc Networks	108
5.1	Introduction	108
5.2	System Model	109
5.3	Maximum Transmission Distance of the Single Hop Cognitive Trans- mission Interfered by the PS	113
5.4	Maximum Transmission Distance of the Interference-Free Single Hop Cognitive Transmission	115
5.5	Cognitive Cooperative Transmission Interfered by the PS	116
5.6	Successful Reception Probability of a Packet of Cognitive Cooperative Transmission Interfered by the PS	118
5.7	Spectral Efficiency and Transmission Power of Cognitive Cooperative Transmission Interfered by the PS	120
5.8	Routing Algorithm	121
5.9	Performance Evaluation	128
5.10	Conclusion	141
6	Overall Conclusion	143
	Bibliography	146

List of Figures

1.1	An example of wireless ad hoc networks.	2
1.2	(a) Propagation of the route request packet. (b) Propagation of the route reply packet.	15
1.3	Route discovery of ADOV.	17
1.4	Network topology with $M - 1$ clusters and L nodes in each cluster.	18
1.5	Relay selection of MFR.	22
1.6	An ad hoc network where three nodes form a cooperative transmission.	26
1.7	An example of the timer-based single relay selection.	33
1.8	An example of the busy-tone-based single relay selection.	34
1.9	An example of the contention-based single relay selection.	35
1.10	Overlay spectrum access.	39
1.11	Positions and contributions of this dissertation.	47
2.1	An example of cooperative communication.	55
2.2	Simplified communication procedure.	59
2.3	Multicast RTS packet format.	59
2.4	Location distribution of the selected relays with adopted relaying protocols with $d_{sd} = 170\text{m}$ ($\gamma_{sd} = 5$ dB).	62
2.5	Location distribution of the selected relays with adopted relaying protocols with $d_{sd} = 116\text{m}$ ($\gamma_{sd} = 10$ dB).	63
2.6	Location distribution of the selected relays with adopted relaying protocols with $d_{sd} = 79\text{m}$ ($\gamma_{sd} = 15$ dB).	64
2.7	BER performances of various relaying schemes for the network of 10, 15, and 20 nodes.	66
3.1	An example of the proposed cooperative MAC protocol with $K = 5$	72
3.2	Number of relay candidates versus the group of the proposed scheme.	77
3.3	Outage probability versus the number of relay candidates.	78
3.4	Number of time slots in the contention period versus the number of relay candidates.	79
3.5	Number of ACK packets versus the number of relay candidates.	80
4.1	Direct and cooperative transmissions in hop $m - 1$ and m , respectively.	84
4.2	An example of the transmission procedure for the DAHR.	88
4.3	An example of AHCR with $M = 4$ and $L = 4$	90
4.4	An example of the transmission procedure for DAHCR scheme 1 and DAHCR scheme 2.	90
4.5	Required transmission power versus the number of contention slots k of the distributed routing schemes with $M = 10$, $L_{max} = 10$, $\eta^p = 0.75$, and $\tau = 1.9$	95
4.6	Delay caused by the contention period per hop versus the number of contention slots k of the distributed routing schemes with $M = 10$, $L_{max} = 10$, $\eta^p = 0.75$, and $\tau = 1.9$	96

4.7	Required transmission power versus the threshold η^p of the distributed routing schemes with $M = 10$, $L_{max} = 10$, $\tau = 1.9$, and $k = 5$	98
4.8	Number of contention periods per hop versus the threshold η^p of the distributed routing schemes with $M = 10$, $L_{max} = 10$, $\tau = 1.9$, and $k = 5$	99
4.9	Required transmission power versus the number of hops M of various routing schemes with $\eta^p = 0.75$, $L_{max} = 5$, $\tau = 1.9$, and $k = 5$	100
4.10	Number of contention periods per hop versus the number of hops M of the distributed routing schemes with $\eta^p = 0.75$, $L_{max} = 5$, $\tau = 1.9$, and $k = 5$	101
4.11	Required transmission power versus the maximum number of nodes in each cluster L_{max} of various routing schemes with $\eta^p = 0.75$, $M = 10$, $\tau = 1.9$, and $k = 5$	102
4.12	Number of contention periods per hop versus the maximum number of nodes in each cluster L_{max} of the distributed routing schemes with $\eta^p = 0.75$, $M = 10$, $\tau = 1.9$, and $k = 5$	103
4.13	Required transmission power versus the throughput τ of various routing schemes with $\eta^p = 0.75$, $M = 10$, $L_{max} = 5$, and $k = 5$	104
4.14	Number of contention periods per hop versus the throughput τ of the distributed routing schemes with $\eta^p = 0.75$, $M = 10$, $L_{max} = 5$, and $k = 5$	105
4.15	Required transmission energy of one transmission procedure per hop versus the data size of one transmission procedure of the distributed routing schemes with $\eta^p = 0.75$, $M = 10$, $L_{max} = 10$, and $\tau = 1.9$	106
5.1	An example of the spectrum usage of the OFDMA system.	110
5.2	The primary transmission coexists with the multihop cognitive transmission.	111
5.3	Two-state Markov chain process.	112
5.4	The primary transmission and the single hop cognitive transmission occur simultaneously.	113
5.5	The PS remains silent when the single hop cognitive transmission occurs.	115
5.6	The primary transmission and the cognitive cooperative transmission occur simultaneously.	116
5.7	Flow chart of the routing algorithm.	122
5.8	Cooperative relay selection.	126
5.9	An example of the routing algorithm.	127
5.10	Average number of cognitive relays versus the probability that the PS is transmitting data to the PD for $d_{PS,CS} = 200\text{m}$	130
5.11	Average number of cognitive relays versus the distance between the PS and the CS for $p_{on} = 0.7$	132
5.12	Average end-to-end reliability versus the probability that the PS is transmitting data to the PD for $d_{PS,CS} = 200\text{m}$	133

5.13	Average end-to-end throughput versus the probability that the PS is transmitting data to the PD for $d_{PS,CS} = 200\text{m}$	134
5.14	Average end-to-end throughput versus the distance between the PS and the CS for $p_{on} = 0.7$	135
5.15	Average required transmission power versus the probability that the PS is transmitting data to the PD for $d_{PS,CS} = 200\text{m}$	136
5.16	Average required transmission power versus the probability that the PS is transmitting data to the PD of the PTBFNR with $\alpha = 4$ for $d_{PS,CS} = 200\text{m}$	138
5.17	Average required transmission power versus the probability that the PS is transmitting data to the PD of the PTBFNR with $\alpha = 5$ for $d_{PS,CS} = 200\text{m}$	139
5.18	Average required transmission power versus the distance between the PS and the CS for $p_{on} = 0.7$	140
5.19	Average end-to-end transmission latency versus the probability that the PS is transmitting data to the PD for $d_{PS,CS} = 200\text{m}$	141
5.20	Average end-to-end transmission latency versus the distance between the PS and the CS for $p_{on} = 0.7$	142

List of Tables

1.1	Outlines of Chapters 2 and 3.	52
1.2	Outlines of Chapters 4 and 5.	53
2.1	Simulation Parameters.	61
2.2	Number of times that various relaying protocols achieve the minimum theoretical BER with different number of nodes.	65
3.1	Simulation Parameters.	76
4.1	Simulation Parameters.	94
5.1	Simulation Parameters.	129

Chapter 1

General Introduction

1.1 Wireless Ad Hoc Networks

1.1.1 Introduction

Over the past decades, we have witnessed a dramatic advancement of wireless technology. Through the first, second, third generations of mobile cellular technologies, we are now approaching and realizing the fourth generation. Currently, not only the transmission reliability, throughput, delay, and consumption energy are improved, but also the size, weight, and cost of mobile devices are largely reduced due to the developments of the semiconductor and material technology. As a result, the popularity of wireless communication devices such as smart phones, personal digital assistants (PDAs), laptops, notebooks, sensors, etc., makes huge wireless information exchange anytime and anywhere all over the world. Wireless technology plays an important role in our daily life.

In cellular based wireless networks, device-to-device communication must be carried out through a central control unit called base station. The base station in one cell arranges all communication procedures from users located in that cell such that no data collision occurs, and the interference is kept under an acceptable level. However, when the data traffic is overloaded, the data packet cannot be handled, and the data buffer will be overflowed at the base station. Different from this kind of communication, wireless ad hoc networks [1]-[3] provide another way that mobile devices transmit data with each other directly. The concept of wireless ad hoc networks was firstly proposed and discussed by the packet radio network (PRNET) project of the U.S. defense advance research projects agency (DARPA). Originally, it was used in battlefields to provide robust multihop transmissions. Wireless ad hoc networks is an autonomous, self-organized communication system without any

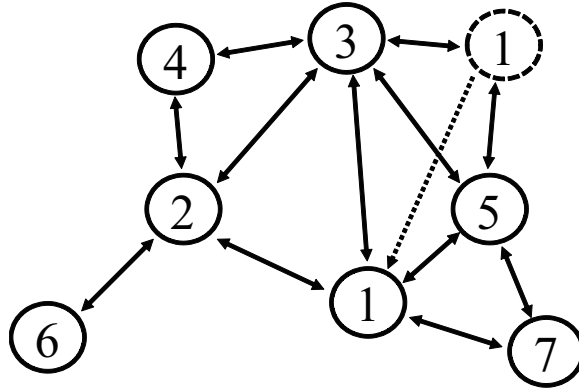

Figure 1.1: An example of wireless ad hoc networks.

support from the centralized infrastructure. Therefore, all transmission procedures are performed in a distributed way. Each node can transmit data with another one if the receiver locates in the transmission range of the sender. Multihop transmission will be necessary if the destination is out of the transmission range of the source. When the destination is far away from the source, a group of intermediate nodes will store and forward data from the source to the destination. Due to the mobility of each node, designing routing protocols becomes a challenging task.

Figure 1.1 illustrates an example of wireless ad hoc networks. This network consists of seven nodes. Two nodes can communicate with each other if the distance between them is shorter than or equal to the transmission distance. The connectivity between two nodes is represented by the solid line with two arrows. The dotted line with one arrow denotes a movement of a node. Before node 1 moves, it has connectivity with nodes 3 and 5. After node 1 moves, in addition to nodes 3 and 5, it also has connectivity with nodes 2 and 7. As a result, after node 1 moves, all nodes in the network must know the new connectivities of node 1 in order to transmit information to or through it. For example, before node 1 moves, if node 6 has data to be transmitted to node 1, the best route may be node 6 \rightarrow node 2 \rightarrow node 3 \rightarrow node 1. However, after node 1 moves, the best route should be node 6 \rightarrow node 2 \rightarrow node 1. Beside, if node 6 wants to transmit data to node 7. Before node 1 moves, the best route may be node 6 \rightarrow node 2 \rightarrow node 3 \rightarrow node 5 \rightarrow node 7.

However, after node 1 moves, the best route should be node 6 \rightarrow node 2 \rightarrow node 1 \rightarrow node 7. Note that only the number of hops is considered in the route selection mentioned above. Thus, the update process of the connectivity of each node plays an important role and must be carefully considered in routing protocols design. In addition, medium access control (MAC) is also an important issue that will largely affect the system performance. Take the topology of Fig. 1.1 as an example, after node 1 moves, node 4 wants to transmit data to node 2, and at the same time, node 3 wants to transmit data to node 1. A suitable MAC mechanism must be designed such that node 4 and 3 will not transmit data packets at the same time to cause a collision at node 2 because node 3 is in the transmission range of node 2 and vice versa. This problem can be easily solved by letting node 4 to preliminarily inform node 3 that data packets will be transmitted to node 2. This can be achieved because node 3 is in the transmission range node node 4 and vice versa. However, when nodes 4 and 6 want to transmit data packets to node 2 at the same time, because node 6 is not in the transmission range of node 4 and vice versa, node 4 can not preliminarily inform node 6 that data packets will be transmitted to node 2. As a result, a more complicated MAC mechanism is necessary to solve this problem.

1.1.2 Characteristics

In wireless ad hoc networks, wireless nodes are randomly distributed in the field, and each node has its own moving pattern. Additionally, due to the random mobility, permanent energy source for each node is impossible, and supplying energy by battery is inevitable. We summarize the main characteristics of wireless ad hoc networks as follows.

- **Dynamic Topologies:** As aforementioned, each node has its own random initial location, and moves with its own pattern. Some nodes always remain stationary, but the other ones periodically switch between stationary and moving mode with random speeds and directions. As a result, the topologies of wireless ad hoc networks always change unpredictably.

- **Unstable Channel Condition:** Wireless mobile nodes suffer from long term path loss signal attenuation and shadowing and short term channel fading that can be modeled by Rayleigh and Rician distributions. Multipath fading that causes intersymbol interference (ISI) is also a serious problem because multiple nodes and obstacles are randomly distributed. In addition, the mobility of each mobile nodes worsens the channel condition.
- **Limited Bandwidth:** Compared to the maximum bandwidth of wireless channels, the bandwidth of wireless ad hoc networks is reduced by the unstable channel condition stated above. Besides, complex MAC protocols that introduce overheads are required to realize multiple multihop transmissions, and multiple additive interference from different transmitters decreases the signal-to-interference-plus-noise ratio (SINR). Therefore, the bandwidth is further reduced.
- **Asymmetric Links:** Take the scenario of Fig. 1.1 as an example, the data transmitted from node 2 to node 3 and from node 3 to node 2 suffer from different wireless channels that are asymmetric. As a result, the fact that node 3 is located in the transmission range of node 2 does not mean that node 2 is also located in the transmission range of node 3. However, due to the difficulty of dealing asymmetric links problem, it is usually assumed that the wireless links between any two nodes are symmetric.
- **Limited Energy Source:** Due to the dynamic movement of each node, batteries with limited life times becomes the main energy source. However, on a mobile node, many tasks that cost energy must be performed. Usually, there is a Central Processing Unit (CPU) with basic computing functionality to execute the command to analyze and processing data. In addition, the operations of wireless communications include the transmitting and receiving data through antenna, analog-to-digital and digital-to-analog conversion, baseband modulation and demodulation, encoding and decoding, channel estimations, rate adaptation, etc. Therefore, how to reduce energy consumption or extend the

battery life is an important issue.

- Control Information Exchange Mechanisms: Due to unpredictable changing of topologies, lots information including the results of predicting moving speeds and direction, the connectivities of mobile nodes, qualities of links, etc, must be distributed over whole network through specified mechanisms in order to establish a route.
- Less Robustness against Attacks: Due to the inherent characteristics of wireless channels, mobile users of wireless ad hoc networks are easier to be attacked than the users using wired networks. In addition, multihop transmissions over long distance increases the chance of being attacked.

1.1.3 Applications

Recently, tremendous research achievements have been done to solve problems of wireless ad hoc networks. However, there are still many technical and cost and economic problems left such that we have not seen so many commercial applications in our daily life. Military purposes are still the main effort to produce applications of wireless ad hoc networks. Here, the main commercial applications are described as follows.

- Military Aspect: For military purpose, it is necessary that applications provide robust, real time, and energy efficient data transmissions. Military applications include monitoring friendly forces, battlefield surveillance, inspection of opposing forces, targeting, damage assessment, and attack detection.
- Wireless Sensor Networks [4], [5]: Sensor networks are another main application of wireless ad hoc networks. DARPA first launched the distributed sensor networks (DSN) program around 1980 in the U.S.A. Hundreds or thousands of sensor nodes are distributed in the field to sense the changing of environments. Generally, a sink is connected to the Internet and collects the observed data transmitted from the source through multihop transmissions. For some

natural observation applications, sensor nodes are placed in somewhere that cannot be easily accessed, and thus, it is impossible to change the battery. Although sensor nodes can also be charged by other natural power sources such as solar, vibration, temperature, etc [6], [7], a stable power source provided by the battery is still required when those natural ones are not available. Thus, energy saving is the main concern of designing communications protocols. There are several usages of wireless sensor networks. We briefly describe them as follows. Environmental usage includes fire detection, flood detection, habitat monitoring, agriculture research, etc. Health usages cover monitoring of human physical data, tracking and monitoring doctors and patients, drug administration, etc. Home usages include home automation smart environment, etc. Other usages include disaster area monitoring and transportation system.

- Personal Area Networks: Various personal electronics devices such as desktop, laptop, printer, mouse, earphone, smart phone, watch, etc, are connected with each other to form a personal area network. Wireless short range transmission is the main feature. Bluetooth [8] is a popular application. Other standards are being defined by IEEE 802.15 task group [9].
- Intelligent Transportation System (ITS) [10]: The main feature of wireless ad hoc networks is to exploit the routing protocol based hop-by-hop transmission methodology to establish a communications link when individual host has its own moving speed and direction. This scenario is practical in new applications such as the ITS or the advanced traveller information system (ATIS) [11]. For example, a driver on the highway may use the ATIS to acquire his favorite restaurant information at the next rest area. The distributed speech recognition (DSR) front-end in the car extracts speech parameters which are then transmitted over the wireless ad hoc network to the back-end recognition server. After recognizing the speech signal, the server sends the restaurant information, which may be a short video introducing the menu, back to the

driver. The driver may again use this system to order his meal in advance. Obviously, the whole information access procedure is dominated by real time multimedia multihop transmissions. Thus, in order to provide high quality multimedia service to customers, robust routing protocols and information processing must be adopted to ensure that the overall system performance meets the quality-of-service (QoS) requirements.

1.1.4 Challenges

Due to its flexibility, autonomy, and distributed behavior, wireless ad hoc networks have been extensively studied to provide better solutions for various issues to further improve the system performance. However, with the advancement of wireless technologies, more and more unseen problems have happened. Recently, global warming is a main research issue that attracts much attention in environmental protection. Therefore, large amounts of observation data of natural environment is required. On the other hand, the frequency of the occurrence of natural disasters increases globally. Both these two aspects accelerate the popularity of wireless sensor networks and make application issues more challenging. In the following, we describe the main challenges that we must face.

- Scalability: Scalability is a critical concern for military and sensor networks applications that communications usually take place over a large area where more mobile nodes are distributed. Due to the increase of the number of mobile nodes, transmissions over a large number of hops occur more often, and the number of candidates of end-to-end multihop routes also increases. Therefore, larger overhead and higher computational complexity are required to exchange route information and select a best end-to-end multiop route, respectively. Because overhead transmissions and computation also consume energy, larger overhead and higher computation complexity shorten battery and network lifetimes.
- Energy Saving: Due to the dynamic topology of wireless ad hoc networks,

mobile nodes must be charged by a battery based power source instead of a permanent one. Besides, as aforementioned, achieving larger scalability consumes more energy. Therefore, energy saving becomes a challenging issue although extending the battery lifetime has gained much research attention. Energy saving can be achieved by developing hardware of mobile nodes to consume low power. In addition, node cooperation can also realize energy saving by sharing the resource to each other.

- QoS: Huge information is delivered through the Internet by various applications such as e-mail, file transfer, video on demand, voice, etc. Different QoS requirements must be satisfied for different applications. However, the inherent characteristics of wireless ad hoc networks make the QoS satisfaction task challenging. QoS metrics include packet loss rate, throughput, delay, jitter, etc. For multihop transmissions, end-to-end QoS metrics are used to evaluate the performance, and the end-to-end routing protocol must be designed such that various end-to-end QoS metrics satisfy their requirements.
- Node Cooperation: Due to large number of mobile nodes, group of nodes can cooperate together to share their resource to improve the system performance. For example, from the source to the destination, intermediate nodes can be grouped into multiple clusters, and nodes in one cluster cooperatively transmit data packets to achieve route diversity. The other kind of cooperation is to exploit the broadcast nature of wireless channels to let the destination able to combine the signals transmitted from the source and relay to improve the signal-to-noise (SNR) ratio. This SNR improvement can be transferred to a reduction of transmission power. That is, the same SNR ratio is achieved by consuming less transmission power.
- Security: Nodes in wireless ad hoc networks suffer from eavesdropping, malicious behavior, infiltration, and so on due to the distributed behavior and dynamic movement and lack of a centralized certification authority. Although security issue has attracted more and more attention recently, tremendous

problems still remain unsolved.

1.1.5 Performance Metrics

Various metrics are used to evaluate the performance of wireless ad hoc networks. We describe them as follows.

- **Control Overhead:** Exchanging information for route establishment and the negotiation for accessing the wireless medium generates large control overhead especially when the network topology is large. Since the control overhead wastes resource, it should be kept as small as possible.
- **End-to-End Reliability:** The end-to-end reliability equals to the multiplication of the successful reception probability of each hop on the route. The successful reception probability is defined as the probability that the SNR measured at the receiver is larger than a pre-defined threshold. As a result, to improve the end-to-end reliability, the number of hops should be reduced or the SNR measured at the receiver of each hop should be increased.
- **End-to-End Throughput:** Multihop transmission usually can be realized with and without concurrency. When transmitting with concurrency, data transmissions taken place in different hops are allowed. However, they will be coordinated such that their QoS requirements are satisfied. In this case, the end-to-end throughput equals to the minimum of throughputs of all hops on the route. On the other hand, when transmitting without concurrency, the data transmission is only allowed in one hop at one period. This causes that the end-to-end throughput equals to the division of the minimum of throughputs of all hops to the number of hops. Therefore, increasing the throughput of each hop or reducing the number of hops can improve the end-to-end throughput.
- **End-to-End Delay:** Generally, for one hop, the total delay consists of the queuing, transmission, and propagation delays. The end-to-end delay can be

shortened by reducing the number of hops. In addition, the data traffic load dominates the queuing delay. Therefore, alleviating the data traffic load can also shorten the end-to-end delay.

- **Power Consumption:** Power consumption should be minimized to extend the battery lifetime. Here, we only consider the total transmission power that equals to the sum of transmission power of each hop on the route. Using higher transmission power in each hop induces less number of hops. Contrarily, more number of hops is caused by using lower transmission power in each hop. Therefore, it is possible that the total transmission power of using higher transmission power in each hop is lower than that of using lower transmission power in each hop.
- **Network Lifetime [12]:** Each node has different initial energy. Thus, although the total energy consumption is reduced, some nodes having less initial energy may first run out of their energy and become useless. This will cause the network transmission function cannot normally work. Therefore, network lifetime that refers the time of normal operation of networks is required to evaluate the performance. There are different definitions of network lifetime in the literature. Network lifetime can be defined as the time that the first node or a part of nodes runs out its energy after the network starts to operate. In addition, network lifetime can also be defined as the number of alive flows or the packet delivery rate. For wireless sensor networks, network lifetime can be defined as the time that the first loss of coverage occurs after the network starts to operate.

1.2 Routing Protocols for Wireless Ad Hoc Networks

1.2.1 Introduction

Routing protocols design plays an important role for providing robust data packet transmissions from the source to the destination. Routing protocols must be

adaptive to the frequent changing of the topology and able to produce the minimum overhead for route information exchanging to save network resources. However, when mobile nodes have high mobility and the number of them is large, designing routing protocols becomes a challenging task.

Globally optimal route can be found by the Bellman-Ford or Dijkstra's algorithms [13], [14]. However, the collection of states of all links of the network generates extremely high overhead, and selecting the optimal route from all possible ones needs a significant amount of calculation. Therefore, globally optimal methods are not practical. Practical routing protocols can be categorized into topology-based and position-based schemes. Topology-based schemes exploit the connectivity information to implement the route selection and data packet forwarding. Topology-based schemes can be further divided into proactive (table driven), reactive (on-demand driven), and hybrid methods.

In proactive method, link connectivity information is periodically exchanged such that each node obtains the information of routes to all possible destinations in the network. Consequently, proactive methods have the advantage of quickly finding the route to the destination, and this results in a shorter delay. However, high mobility and large number of mobile nodes causes a significant amount of overhead and a large waste of resource. In reactive methods, the route to the destination is only established when it is necessary. Therefore, compared to proactive methods, less overhead and network capacity are used. However, the reactive characteristic causes a longer delay to find a route to the destination. Additionally, the generation of a significant amount of overhead is still inevitable when nodes are with high mobility, and the number of nodes is large. In hybrid methods, the proactive and reactive characteristics are combined to improve the performance. Usually, the local connectivity is established in a proactive way, and a longer route is found in a reactive way. A hierarchy structure such as a cluster is often exploited.

In position-based schemes, each node can know its own position by equipping with global position system (GPS) or using other positioning techniques. Besides, by exchanging the position information, each node is able to obtain positions of its

neighbor nodes [15]. The source usually can obtain the position of the destination by using the location service. Thus, the position of the destination can be recorded in data packets transmitted from the source. The node that receives data packets can use positions of the destination and its neighbor nodes to determine the next node for relaying data packets. However, it is difficult to implement the exchanging of positions of a node and its neighbor ones, and large overhead may be generated. Thus, it is required to select relay nodes distributedly. A group of nodes that receive data packets can exploit their own positions and the positions of the source and destination to send control packets back to the previous node to contend for being selected as the relay node. Compared with topology-based schemes, there is no need to establish the route before data packet forwarding. However, the hardware complexity is increased by equipping GPS or using other positioning techniques.

1.2.2 Proactive Routing Schemes

In this subsection, we describe two typical proactive routing schemes: destination-sequence distance-vector (DSDV) and wireless routing protocol (WRP).

1.2.2.1 Destination-Sequence Distance-Vector Protocol

DSDV [16] is typically a table-driven routing protocol. Every node establishes a routing table which records the number of hops required to reach all available nodes in the topology. A sequence number originated by the destination is tagged to each table entry. This number determines the freshness of a route. When selecting one route among two, the route which has a greater sequence number is preferable. If the two sequence numbers are equal, the route with a lower metric will be selected. Every node periodically exchanges and updates the routing table information with each other. But, when the topology changes fast, the newest routing information can not be caught and updated immediately. As a result, according to the old routing table, the data will probably be forwarded to the destination through a broken route. This condition will cause large packet loss in the presence of high

mobility.

1.2.2.2 Wireless Routing Protocol

In WRP [17], by receiving acknowledgments and other messages, each node can obtain the existence information of its neighbor nodes. To confirm the connectivity, a HELLO message must be sent within a specified time period by each node if there is no data packet transmissions. If no HELLO messages are received, the wireless link is judged as a failure link. After a node receives the HELLO message from another new node, it adds the information of the new node into its routing table and sends the routing table to the new node. In WRP, each node must obtain four routing tables. They are distance table, routing table, link-cost table, and message retransmission list (MRL) table. The number of hops of a route between a node and the destination is recorded in the distance table. The routing table records the next node. The link delay is obtained in the link-cost table. The MRL table records four items. They are the sequence number of the update message, a retransmission counter, a flag vector that indicates the requirement of an acknowledgment, and a list of updates that are sent in the update message. The updates that need to be retransmitted and the neighbors that should acknowledge the retransmission are obtained by the MRL table. A node periodically sends update messages to its neighbor nodes to keep the route information accurate. The update message has a list of updates that includes the destination, the distance to the destination, and the predecessor of the destination. In addition, a list of responses indicating the nodes that need to acknowledge the update is also included in the update message. After processing the update message received from neighbor nodes or when a change of links is detected, a node transmits update message. When a node detects the failure of a link, it will send update messages to its neighbors nodes. Then, the distance tables of those neighbor nodes will be modified, and novel possible routes will be confirmed.

1.2.3 Reactive Routing Schemes

In this subsection, we describe two typical reactive routing schemes: dynamic source routing (DSR) and ad hoc on-demand distance vector (AODV).

1.2.3.1 Dynamic Source Routing

DSR [18] searches the route from the source to the destination in an on-demand way. Each node obtains the information of the route from the source to it in its route cache, and the route information is updated continuously to learn new routes. DSR consists of two phases: route discovery and route maintenance. When the source wants to transmit data packets, it will first check if there is already an unexpired route in its route cache. If there exists such a route, the source will use this route to transmit data packets. Otherwise, the route discovery is initiated, and the source broadcasts a route request packet. The addresses of the source and the destination and a unique identification number are included in the route request packet. Each node that receives the route request packet checks if it has a route to the destination. If it does not, its own address will be added to the route record of the route request packet, and the route request packet will be further broadcasted. To limit the number of route request packets broadcasted from a node, a node broadcasts the route request packet only when it has not seen this route request packet, and its address has not appeared yet in the route record. When an intermediate node that has a route to the destination receives the route request packet or when the destination receives it, a route reply packet will be generated and sent back to the source. When the node that receives the route request packet is an intermediate node that has a route to the destination, it will add its cached route to the route record and copy this new route record into the route reply packet. When the node that receives the route reply packet is the destination, the route record will be copied into the route reply packet. Fig. 1.2 illustrates propagations of the route request and reply packets. Route error packets and acknowledgments are used for the route maintenance. A node generates route error packets when a serious transmission

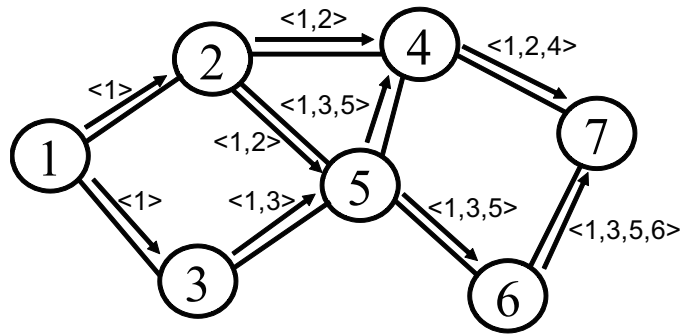

(a)

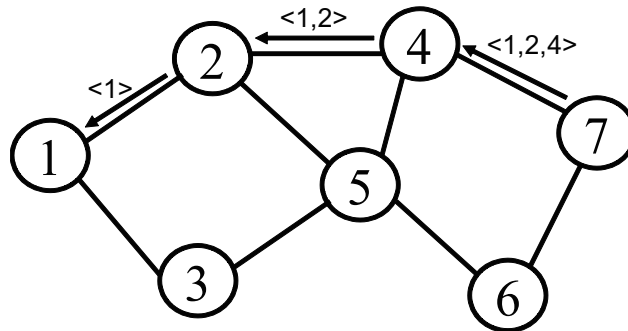

(b)

Figure 1.2: (a) Propagation of the route request packet. (b) Propagation of the route reply packet.

failure problem happens. After a node receives a route error packet, it will remove the hop with errors from its route cache and truncate all routes associated with that hop. Acknowledgments are used to confirm successful receptions of data packets.

1.2.3.2 Ad Hoc On-Demand Distance Vector Routing

AODV [19] routing protocol discover a transmission path based on the on-demand fashion. Specifically, the nodes that do not act as routers or intermediate stations along an established link have no obligation to perform any path searching or maintenance operation defined in the routing protocol. The path discovery procedure will only be initiated when two nodes need to communicate. We now briefly

describe the routing mechanism. As the path discovery is started, a packet called route request (RREQ) is broadcasted by the source node to neighbors. This kind of packet will be transmitted hop-by-hop until reaching a node which has a route to the destination. Note that an intermediate node may receive multiple duplicates of the same RREQ. If this happens, the node will drop this RREQ instead of broadcasting it again. A reverse path will be automatically established when the RREQ passes through the intermediate nodes. When the RREQ arrives at a node having an available link to the destination, this node will send a packet called route reply (RREP) back to the source node along the pre-constructed reverse path. A forward pointer giving the direction where the RREP comes from will be set up when the RREP goes through every node along the reverse path. Fig. 1.3 illustrates the route discovery of AODV. Once the source node receives the RREP, the data transmission will be started. On the other hand, if any node along the transmitting path fails to communicate, a special RREP will be broadcasted to notify every active source node. The source node can then initiate another path discovery procedure if it still needs to communicate to the destination.

1.2.4 Hybrid Routing Schemes

In this subsection, we describe two typical reactive routing schemes: zone routing protocol (ZRP) and cluster based routing protocol.

1.2.4.1 Zone Routing Protocol

ZRP [20], [21] searches the route by using a combination of proactive and reactive ways. In addition, the area is divided into multiple routing zones, and there are a zone head and other member nodes in a routing zone. A routing zone can be overlapped by other ones. Every node can act as a zone head and a member node of a zone. The intrazone routing protocol (IARP) is used to let a node have a route to all the other nodes in a zone. The proactive link-state or distance-vector routing is employed to implement IARP. If the destination is not in the zone of the

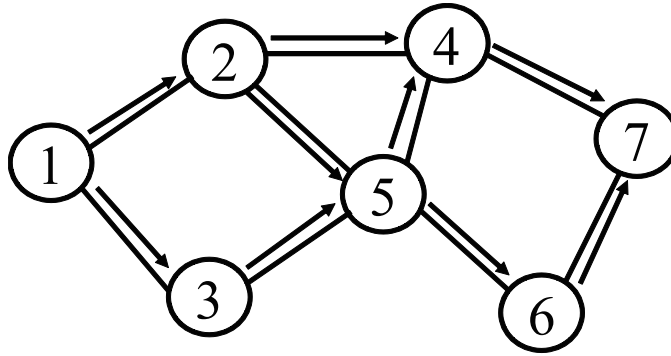

(a)

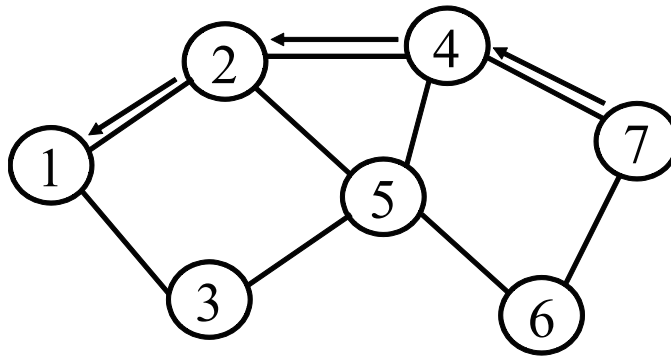

(b)

Figure 1.3: Route discovery of ADOV.

source, the interzone routing protocol (IERP) is exploited to find a route to a node that is in the other zone. IERP operates in an on-demand fashion. Due to the operation of different routing protocols, it is difficult to sustain a stable routing in ZRP.

1.2.4.2 Cluster-Based Routing Protocols

In [22], the optimal routing and the ad hoc routing (AHR) have been proposed to search the route with the minimum end-to-end outage in cluster-based multihop networks. Here, we introduce these two routing algorithms, when they are applied to search the route that requires the minimum transmission power to achieve the

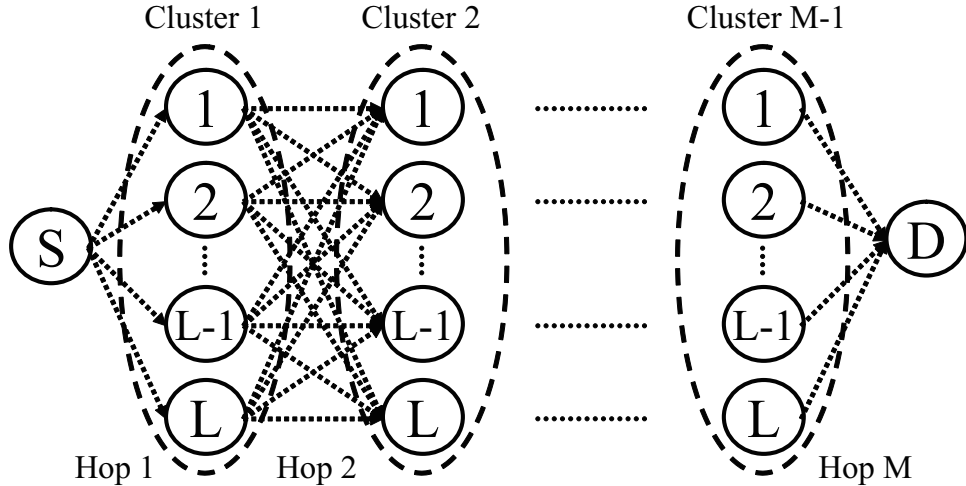

Figure 1.4: Network topology with $M - 1$ clusters and L nodes in each cluster.

end-to-end throughput. Besides, we give a note on the throughput of each link.

We consider a M -hop network topology in which $M - 1$ clusters randomly fulfill the space between the source and the destination. Each cluster consists of L nodes. Fig. 1.4 illustrates the network topology. We assume that the clusters are previously formed by the known schemes proposed in [23]. The problem of the cluster formation is not considered here. Let $P_{S,j,1}$ and $P_{j,D,M}$ represent the transmission power required to achieve the object throughput of the links between the source and node j in cluster 1 and between node j in cluster $M - 1$ and the destination, respectively. Let $P_{i,j,m}$ denote the transmission power required to achieve the object throughput of the links between node i in cluster $m - 1$ and node j in cluster m , where $i = 1, \dots, L$, $j = 1, \dots, L$, and $m = 2, \dots, M - 2$.

In the optimal routing, the optimal route is discovered by the well known Viterbi algorithm. Let $P_{j,m}^{min}$ and $P_{D,M}^{min}$ be the transmission power required to achieve the object throughput of the optimal route from the source to node j in cluster m and the destination, respectively, where $i = 1, \dots, L$ and $m = 1, \dots, M - 1$. Let $N_{j,m}^{min}$ represent the node that is in cluster $m - 1$ and passed by the optimal route from the source to node j in cluster m , where $j = 1, \dots, L$ and $m = 2, \dots, M - 1$. Let $N_{D,M}^{min}$ denote the node that is in cluster $M - 1$ and passed by the optimal

route from the source to the destination. For hop $m = 1$, let $P_{j,m}^{min} = P_{S,j,1}$, where $j = 1, \dots, L$. Because the optimal route to each node in cluster 1 is from the source, we have $N_{j,1}^{min} = S$, where $j = 1, \dots, L$. For hop $m = 2, \dots, M - 1$, let $P_{j,m}^{min} = \min_{i=1, \dots, L} P_{i,m-1}^{min} + P_{i,j,m}$, $i^* = \arg \min_{i=1, \dots, L} P_{i,m-1}^{min} + P_{i,j,m}$, and $N_{j,m}^{min} = i^*$, where $j = 1, \dots, L$. For the last hop M , let $P_{D,M}^{min} = \min_{i=1, \dots, L} P_{i,M-1}^{min} + P_{i,D,M}$, $i^* = \arg \min_{i=1, \dots, L} P_{i,M-1}^{min} + P_{i,D,M}$, and $N_{D,M}^{min} = i^*$, where $j = 1, \dots, L$. The final step is to output the nodes memorized in $N_{j,m}^{min}$. Let N_m be the node passed by the optimal route in cluster m , where $m = 1, \dots, M - 1$. For cluster $m = M - 1$, $N_{M-1} = N_{D,M}^{min}$. For cluster $m = M - 2, \dots, 1$, $N_m = N_{N_{m+1}, m+1}^{min}$. Then, the optimal route can be written as $\{S, N_1, \dots, N_{M-1}, D\}$.

Optimal routing can be implemented only when there is a central controller obtaining the CSI of all links of all possible routes. From the algorithm described above, we can get that total $2(M-2)L^2 - (M-4)L - 1$ comparisons are performed at the central controller. When M and L are large, the computational complexity is quite high. Besides, the total number of all links of all possible route is $2L + (M-2)L^2$. When M and L are large, estimating the CSI of all links of all possible routes and sending the results to the central controller cause quite high computational complexity and large overhead.

In order to reduce the computational complexity and the overhead of the optimal routing, the AHR which performs in a hop-by-hop fashion is proposed. In the AHR, for hop $m = 1$, among the links from the source to each node in cluster 1, the link whose object throughput is achieved by the the minimum required transmission power is selected. That is, $j^* = \arg \min_{j=1, \dots, L} P_{S,j,1}$, where j^* is the selected receiver in cluster 1. For hop $m = 1, \dots, M - 2$, among the links from the sender i^* in cluster $m - 1$ to each node in cluster m , the link whose object throughput is achieved by the minimum required transmission power is selected. That is $j^* = \arg \min_{j=1, \dots, L} P_{i^*,j,m}$, where j^* is the selected receiver in cluster m . To select the node in cluster $M - 1$, we first calculate $P_{i^*,j,M-1} + P_{j,D,M}$ that represents the transmission power required to achieve the object throughput of the path passing through node j in cluster $M - 1$ between the sender i^* in cluster $M - 2$ and the destination, where $j = 1, \dots, L$. The

path whose object throughput is achieved by the minimum required transmission power is selected. That is, $j^* = \arg \min_{j=1,\dots,L} P_{i^*,j,M-1} + P_{j,D,M}$, where j^* is the selected passing node in cluster $M - 1$.

The AHR can be implemented in a distributed or centralized way. We will present a distributed implementation in Chapter 4. When the AHR is implemented in a centralized way, from the algorithm described above, we can get that total $M(L - 1) + 1$ comparisons are performed at the central controller. Besides, the CSI of ML links must be estimated and sent to the central controller. Compared to the optimal routing, implementing the AHR in a centralized way requires less computational complexity and overhead.

In order to reduce the computational complexity and the overhead of the optimal routing, the AHR which performs in a hop-by-hop fashion is proposed. In the AHR, for hop $m = 1$, among the links from the source to each node in cluster 1, the link whose object throughput is achieved by the the minimum required transmission power is selected. That is, $j^* = \arg \min_{j=1,\dots,L} P_{S,j,1}$, where j^* is the selected receiver in cluster 1. For hop $m = 1, \dots, M - 2$, among the links from the sender i^* in cluster $m - 1$ to each node in cluster m , the link whose object throughput is achieved by the minimum required transmission power is selected. That is $j^* = \arg \min_{j=1,\dots,L} P_{i^*,j,m}$, where j^* is the selected receiver in cluster m . To select the node in cluster $M - 1$, we first calculate $P_{i^*,j,M-1} + P_{j,D,M}$ that represents the transmission power required to achieve the object throughput of the path passing through node j in cluster $M - 1$ between the sender i^* in cluster $M - 2$ and the destination, where $j = 1, \dots, L$. The path whose object throughput is achieved by the minimum required transmission power is selected. That is, $j^* = \arg \min_{j=1,\dots,L} P_{i^*,j,M-1} + P_{j,D,M}$, where j^* is the selected passing node in cluster $M - 1$.

The AHR can be implemented in a distributed or centralized way. We will present a distributed implementation in Chapter 4. When the AHR is implemented in a centralized way, from the algorithm described above, we can get that total $M(L - 1) + 1$ comparisons are performed at the central controller. Besides, the CSI of ML links must be estimated and sent to the central controller. Compared

to the optimal routing, implementing the AHR in a centralized way requires less computational complexity and overhead.

The throughput of each link must be equal to the objective end-to-end throughput. Otherwise, it is possible that the end-to-end throughput of the selected route from the source to the destination is not equal to the objective end-to-end throughput. If only one link of the selected route from the source to the destination has the throughput that is lower than the objective end-to-end throughput, the end-to-end throughput of the selected route from the source to the destination reduces to the throughput of that link. If more than one link of the selected route from the source to the destination have the throughput that is lower than the objective end-to-end throughput, the end-to-end throughput of the selected route from the source to the destination reduces to the minimum of the throughput of those links. If no link of the selected route from the source to the destination has the throughput that is lower than the objective end-to-end throughput, and at least one link of the selected route from the source to the destination has the throughput that is higher than objective end-to-end throughput, the transmission power required to achieve the end-to-end throughput of the selected route from the source to the destination is increased and thus not minimum.

1.2.5 Position-Based Routing Schemes

In this Subsection, we introduce two typical position-based routing schemes: the most forward within radius R (MFR) [24] and greedy forwarding [25]. As aforementioned, each node can obtain its own position by using the equipped GPS or other positioning techniques, and the source can have the position of the destination. In addition, due to the information exchange with neighbor nodes, each node can obtain positions of its neighbor nodes.

In the most forward within radius R scheme, the data packet is transmitted in a hop-by-hop way. Figure 1.5 illustrates the relay selection of MFR. Nodes S and D represent the source and destination, respectively. Let M denote the number of hops. R_i is the relay on the route, where $i = 1, \dots, M-1$. d_0 denotes the transmission

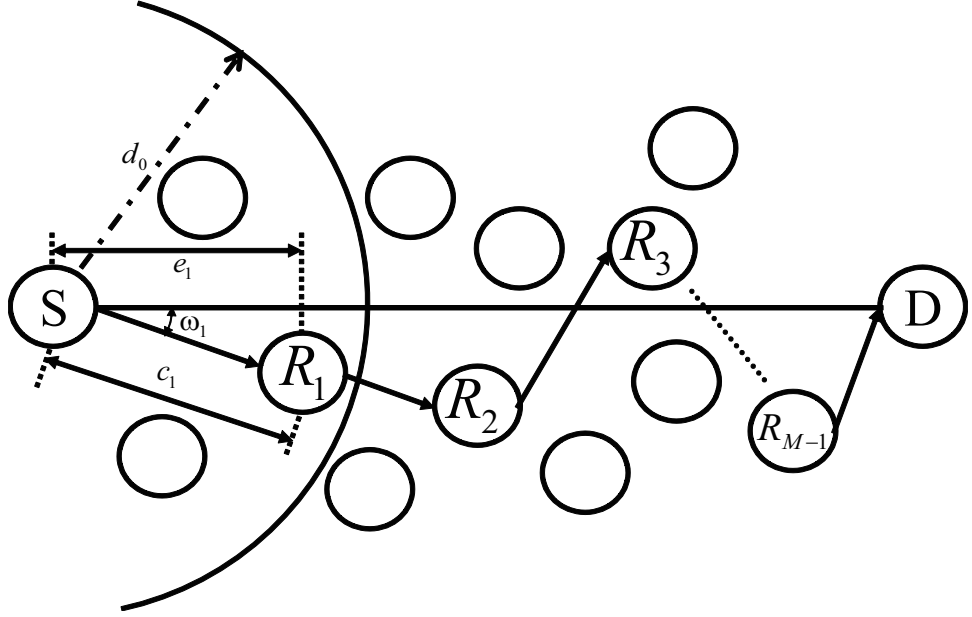

Figure 1.5: Relay selection of MFR.

distance of the source. c_1 represents the distance between the source and node R_1 . ω_1 is $\angle(R_1 - S - D)$. e_1 denotes the length of the projection of c_1 on the line between the source and destination and can be calculated as $c_1 \cos \omega_1$. Before the source starts to transmit data packet, it obtains the position of the destination by using the location service. The source also obtains positions of nodes locating in its transmission range by using information exchanges. All nodes locating in the transmission range of the source have corresponding angles between lines connecting the source and themselves and the line connecting the source and the destination. ω_1 is one of these angles. In addition, they also have corresponding lengths of projections of distances between the source and themselves on the line connecting the source and destination. e_1 is one of these lengths. The source can calculate these angles and lengths because it has positions of itself, the destination, and all nodes locating in its transmission range. Then, among all nodes locating in the transmission range of the source, the node that its corresponding length of projection is longest is selected as the relay to receive and forward data packets transmitted from the source. In Fig. 1.5, node R_1 is selected as the relay because its corresponding e_1 is longest among all nodes

locating in the transmission range of the source. The source will copy the position of the destination into data packets before they are sent to node R_1 . Thus, node R_1 can obtain the position of the destination after data packets are received from the source. Node R_1 can use the aforementioned relay selection method to find node R_2 . Then, R_1 will send data packets to node R_2 . The aforementioned operation is repeated until data packets reach node R_{M-1} whose one hop neighbor nodes include the destination. Finally, node R_{M-1} sends data packets to the destination.

In the greedy forwarding scheme, among nodes locating in the transmission range of the sender, the node that has the closest distance to the destination is selected as the receiver. To accomplish this, the source copies the position of the destination into data packets before they are sent. After the receiver is selected, the sender sends data packets to the selected receiver. The receiver selection and data packets transmission are repeated until data packets reach a node whose one hop neighbor nodes include the destination. Finally, data packets are sent to the destination.

1.3 Cooperative Transmissions and Networking

1.3.1 Introduction

For wireless communications and networking, transmitted signals suffer from the large scale pathloss and shadowing and small scale fading. The effects caused by these inherent characteristics of wireless channels can be mitigated by diversities provided in different domains including time, spatial, and frequency. In wireless ad hoc networks, due to the characteristic of dynamic topology and broadcast nature of wireless channels, abundant spatial diversity can be obtained and exploited. Relay-assisted or cooperative transmissions provide an efficient way to exploit spatial diversity to improve the system performance. Therefore, it is suitable to apply cooperative transmission in wireless ad hoc networks. Due to size and power limitations, mobile nodes are usually allowed to equip with only one single antenna. By grouping the single-antenna-based mobile nodes to form a virtual antenna ar-

ray, cooperative transmissions can achieve performance improvements brought by multi-input multi-output (MIMO) technique. With the broadcast nature of wireless channel, several neighboring nodes can overhear the signals transmitted from the source. These nodes then share their resources to process the signals and forward them to the destination. This collaborative operation can further improve data rates, extends transmission range, and relaxes the high transmitting power constraint for providing better reliability.

Originally, the idea of cooperative diversity was first addressed in the works of van der Meulen [26] and Cover and El Gamal [27] who investigated the information theoretic capacity of relay channels. Recently, Sendonaris et al. [28], [29] proposed the concept of user cooperation diversity and analyzed its capacity, outage probability, and coverage in an information theoretic way. The practical implementation issue and performance analysis of user cooperation in a low-rate code-division multiple-access (CDMA) system were also presented. Laneman et al. [30] proposed several efficient cooperative diversity protocols and investigated their outage probability performances and properties of diversity-multiplexing tradeoff. These cooperative diversity protocols can be classified into two groups: fixed relaying protocols and adaptive relaying protocols. In fixed relaying protocols, the whole transmission period consists of two phases. In the first phase, the source transmits the signals and all the relay nodes and the destination listen. In the second phase, all the relay nodes process the overheard signals and forward them to the destination. The most popular processing methods at relay nodes are amplify-and-forward (AF) and decode-and-forward (DF). In the AF, the relay simply amplifies and forwards the overheard signal. Thus, it is quite popular due to its low complexity for practical implementation. However, the destination suffers from the noise amplification, especially when the received SNR at the relay is poor. In contrast to the AF, when the DF is applied, the overheard signal at the relay is decoded, and the decoded one is re-encoded. Then, the re-encoded signal is forwarded to the destination. The DF is able to remove the noise effect at the expense of the processing delay and the high complexity for practical implementation.

Because the whole transmission period is divided into two phases, and the same information is transmitted two times, fixed relaying protocols have the disadvantage of low throughput. When the SNR of the wireless channel between the source and destination is high, most of data packets transmitted from the source can be decoded successfully at the destination in the first phase, and thus, the channel resource of the second phase is wasted. This causes that the problem of low throughput becomes more serious. Adaptive relaying protocols overcome this problem by using the channel resource adaptively. Selective and incremental relaying are two popular adaptive relaying protocols. In selective relaying, the relay decodes and forwards the data packet overheard from the source when the SNR of the signal received at the relay is higher than a defined threshold. Otherwise, the relay remains idle. In incremental relaying, the relay or the source retransmits the data packet only when the destination cannot decode the data packet transmitted from the source successfully. To accomplish this, it is necessary to construct a feedback channel from the destination to the relay or the source. Thus, the implementation complexity is increased.

1.3.2 Transmission Model

An ad hoc network where three nodes form a cooperative transmission is shown in Fig. 1.6. Node S, R, and D represent the source, relay, and destination, respectively. P_s and P_r denote the transmission power of the source and relay, respectively. h_{sd} , h_{sr} , and h_{rd} represent the Rayleigh fading coefficients of wireless channels between the source and the destination, the source and the relay, and the relay and the destination, respectively. Zero-mean, independent, circularly symmetric complex Gaussian random variables with variances σ_{sd}^2 , σ_{sr}^2 , and σ_{rd}^2 are used to model h_{sd} , h_{sr} , and h_{rd} , respectively. Each node is assumed to have a single antenna due to size and power constraint. Only half duplex is considered. This means that each node cannot transmit and receive data packets simultaneously. The effects of the short term Rayleigh fading are considered in the channel model of each link. Over one frame interval, we assume the channel coefficients are static and change

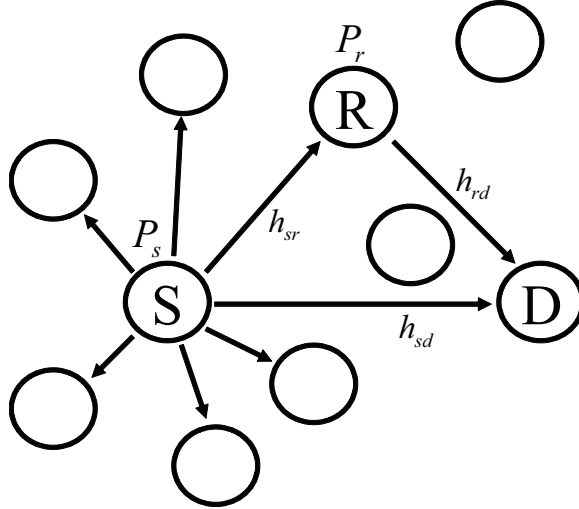

Figure 1.6: An ad hoc network where three nodes form a cooperative transmission.

independently from one frame interval to another.

1.3.3 Fixed Relaying Protocols

1.3.3.1 Amplify-and-Forward Relaying Protocol

In AF, the relay simply amplifies and forwards the overheard signal to the destination. For simplicity, we assume that the source and the relay use the same transmission power P . In the first time slot, the source transmits signal x , and the received signals y_r and $y_{d,1}$ at the relay and the destination can be presented as

$$y_r = \sqrt{P}h_{sr}x + n_{sr} \quad (1.1)$$

$$y_{d,1} = \sqrt{P}h_{sd}x + n_{sd} \quad (1.2)$$

where n_{sr} and n_{sd} are additive noise observed at the relay and the destination when the source is the sender, respectively, and modeled as zero mean complex Gaussian random variables with variance N_0 . In the second time slot, the relay amplifies the received signal y_r and transmits it to the destination. The received signal $y_{d,2}$ at the destination can be formulated as

$$y_{d,2} = \sqrt{P}h_{rd}\beta y_r + n_{rd} \quad (1.3)$$

where β denotes an amplification factor, and n_{rd} is additive noise observed at the destination when the relay is the sender and modeled as zero mean complex Gaussian random variables with variance N_0 . β is defined such that the fading effect of the wireless channel between the source and the relay is equalized. This can be done by letting β equal to $\sqrt{P/(P|h_{sr}|^2 + N_0)}$.

To obtain the mutual information between the source and the destination, we must calculate the instantaneous SNR observed at the destination. The destination uses the Maximal Ratio Combining (MRC) technique to combine the signals transmitted from the source and the relay resulting in a virtual multi-input single-output (MISO) system. The instantaneous SNR observed at the destination can be calculated as

$$\gamma_d = \gamma_{sd} + \frac{\gamma_{sr}\gamma_{rd}}{\gamma_{sr}\gamma_{rd} + 1}, \quad (1.4)$$

where $\gamma_{sd} = P|h_{sd}|^2/N_0$, $\gamma_{sr} = P|h_{sr}|^2/N_0$, and $\gamma_{rd} = P|h_{rd}|^2/N_0$. Therefore, the mutual information between the source and the destination can be written as

$$I_{AF} = \frac{1}{2} \log \left(1 + \gamma_{sd} + \frac{\gamma_{sr}\gamma_{rd}}{\gamma_{sr}\gamma_{rd} + 1} \right). \quad (1.5)$$

From (1.5), the outage probability at high SNR can be approximated as [30]

$$Pr(I_{AF} < R) \sim \left(\frac{\sigma_{sr}^2 + \sigma_{rd}^2}{2\sigma_{sd}^2\sigma_{sr}^2\sigma_{rd}^2} \right) \left(\frac{(2^{2R} - 1)N_0}{P} \right)^2, \quad (1.6)$$

where R is the transmission rate in each time slot.

1.3.3.2 Decode-and-Forward Relaying Protocol

In DF, the relay decodes the overheard signal and re-encodes the decoded one. Then, the relay forwards the re-encoded signal to the destination. For simplicity, we assume that the source and the relay use the same transmission power P . In the first time slot, the source transmits signal x , and the received signals y_r and $y_{d,1}$ at the relay and the destination can be presented as

$$y_r = \sqrt{P}h_{sr}x + n_{sr} \quad (1.7)$$

$$y_{d,1} = \sqrt{P}h_{sd}x + n_{sd} \quad (1.8)$$

where n_{sr} and n_{sd} are additive noise observed at the relay and the destination when the source is the sender, respectively, and modeled as zero mean complex Gaussian random variables with variance N_0 . After decoding and re-encoding the overheard signal, in the second time slot, the relay forwards signal \hat{x} that is the decoded result to the destination. The received signal $y_{d,2}$ at the destination can be formulated as

$$y_{d,2} = \sqrt{P}h_{rd}\hat{x} + n_{rd} \quad (1.9)$$

where n_{rd} is additive noise observed at the destination when the relay is the sender and modeled as zero mean complex Gaussian random variables with variance N_0 . Although DF has the advantage of removing the noise effect at the relay, it is possible that the incorrect decoding result is forwarded to the destination, and thus, the error propagation occurs to degrade the performance. Subject to the requirement that the relay forwards signal x to the destination only when it correctly decodes signal x from the overheard signal, the mutual information between the source and the destination can be given by

$$I_{DF} = \frac{1}{2} \min\{\log(1 + \gamma_{sr}), \log(1 + \gamma_{sd} + \gamma_{rd})\}. \quad (1.10)$$

From (1.10), the outage probability at high SNR can be approximated as [30]

$$Pr(I_{DF} < R) \sim \frac{(2^{2R} - 1) N_0}{\sigma_{sr}^2 P}, \quad (1.11)$$

where R is the transmission rate in each time slot.

1.3.4 Adaptive Relaying Protocols

Fixed relaying protocols need twice the time to transmit one data packet from the source to the destination compared to the direct transmission. As a result, the throughput of adaptive relaying protocols is only half of that of the direct transmission. In addition, when the destination can correctly decode the data packets transmitted from the source in the first time slot, the channel resource of the second time slot exploited by the relay is wasted. This condition occurs when the SNR of the wireless channel between the source and the destination is high. To combat this

problem, adaptive relaying protocols that efficiently use the channel resource are proposed. In the following, we describe two adaptive relaying protocols: selective DF relaying and incremental relaying.

1.3.4.1 Selective DF Relaying

In the selective DF relaying, the relay performs the decoding, re-encoding, and forwarding process if the SNR of the received signal at the relay is higher than a defined threshold. Otherwise, the relay remains idle. In the fixed DF relaying, the relay forwards the re-encoded signal to the destination even when the decoded result of the overheard signal is incorrect. Thus, the performance is degraded due to the error propagation. Compared to the fixed DF relaying, the selective DF relaying can improve the performance because the threshold can be defined such that the relay is probably able to correctly decode the overheard signal. When both the source and the relay use transmission power P to transmit, the mutual information between the source and the destination can be expressed as

$$I_{SDF} = \begin{cases} \frac{1}{2} \log(1 + 2\gamma_{sd}), & |h_{sr}|^2 < (2^{2R} - 1) P/N_0, \\ \frac{1}{2} \log(1 + \gamma_{sd} + \gamma_{sr}), & |h_{sr}|^2 \geq (2^{2R} - 1) P/N_0, \end{cases} \quad (1.12)$$

where $\gamma_{sd} = P|h_{sd}|^2/N_0$, $\gamma_{sr} = P|h_{sr}|^2/N_0$, $\gamma_{rd} = P|h_{rd}|^2/N_0$, R is the transmission rate in each time slot, and N_0 is the variance. From (1.12), the outage probability at high SNR can be approximated as [30]

$$Pr(I_{SDF} < R) \sim \left(\frac{\sigma_{sr}^2 + \sigma_{rd}^2}{2\sigma_{sd}^2\sigma_{sr}^2\sigma_{rd}^2} \right) \left(\frac{(2^{2R} - 1) N_0}{P} \right)^2. \quad (1.13)$$

1.3.4.2 Incremental Relaying

In the incremental relaying, the relay forwards the information in the second time slot only when the destination cannot correctly decode the information transmitted in the first time slot. To accomplish this, the destination needs to inform its decoding result to the source and the relay. Thus, it is necessary to construct a feedback channel. If the decoding at the destination is correct, in the second time slot,

the source transmits new information, and the relay remains idle. Thus, the spectral efficiency is improved compared to the fixed relaying protocols. The transmission rate of the system is a random variable depending on whether the destination can successfully decode the signal received from the source or not. Let R denote the transmission rate in each time slot. The transmission rate of the system is R if the destination correctly decodes the signal received from the source. If the destination cannot perform the correct decoding of the signal received from the source, the transmission rate of the system is $R/2$. As a result, the average transmission rate can be written as

$$\begin{aligned}\bar{R} &= RPr[|h_{sd}|^2 \geq (2^{2R} - 1)P/N_0] + \frac{R}{2}Pr[|h_{sd}|^2 < (2^{2R} - 1)P/N_0] \\ &= \frac{R}{2} \left[1 + \exp\left(-\frac{(2^R - 1)N_0}{P}\right) \right],\end{aligned}\quad (1.14)$$

where P is the transmission power of the source and the relay, and N_0 is the variance of the complex Gaussian random variable. When the relay needs to forward the information in the second time slot, it can use any of the fixed relaying protocols. When the AF relaying technique is used, the outage probability at high SNR can be approximated as [30]

$$Pr(I_{IAF} < R) \sim \left(\frac{\sigma_{sr}^2 + \sigma_{rd}^2}{2\sigma_{sd}^2\sigma_{sr}^2\sigma_{rd}^2} \right) \left(\frac{(2^{\bar{R}} - 1)N_0}{P} \right)^2. \quad (1.15)$$

1.3.5 Hybrid Relaying Schemes

According to the previous research works, the performances of cooperative system adopting the AF and the DF relaying are totally different for a given SNR. The performance of AF relaying highly relates to the channel condition of the source-to-relay link. On the other hand, the performance of DF relaying is determined by whether or not the relay terminal can decode the overheard signal correctly. Therefore, it is necessary to consider the hybrid relaying schemes that can adaptively deploy the relaying protocol.

In the literature, several hybrid relaying schemes have been proposed to adaptively employ the AF or the DF at the relay to further improve the system per-

formance. In [31], if the instantaneous SNR condition of the source-to-relay link is good, the relays select the DF. Otherwise, the AF is performed. However, according to the BER analysis provided by [32] and [33], the performances of the AF and the DF are affected by not only the SNR condition of the source-to-relay link but also the SNR conditions of the source-to-destination and the relay-to-destination links. Therefore, in [34], considering the SNR conditions of all links, a hybrid forwarding scheme in orthogonal frequency division multiplexing (OFDM) based networks was proposed to choose the relaying protocol which can achieve the minimum BER on per sub-carrier. In [35], the relaying protocol was selected based on whether or not the relay candidate can decode the overheard data correctly. The relay candidates that succeed in the decoding will be set to use the DF and the others will be set to use the AF. Finally, the relay candidate that achieves the maximum destination SNR will be selected to forward the data.

1.3.6 Single Relay Selection Schemes

In [36], for the multiple relay based cooperative networks, the authors propose the distributed space-time-coded protocol that coordinates the data retransmissions from a group of relays such that full diversity is obtained. However, in wireless ad hoc networks, it is hard to implement this protocol due to its required knowledge of the global CSI and coordination between the participated relays. In [37], it is demonstrated that the single relay selection and the distributed space-time-coded protocol proposed in [36] achieve the same diversity-multiplexing tradeoff. In addition, implementing the single relay selection generates less signal overhead and does not require the distributed space-time coding or the cooperative beamforming.

Various single relay selection schemes have been proposed in [38]-[41]. For the cellular multihop networks, [38] presented the relay terminal selections based on the physical distance and the pathloss. In [39], the idea of exploiting the harmonic mean of channel quality to select the best relay terminal was addressed. For the indoor wireless local area networks (WLANs), a nearest neighbor selection scheme was presented in [40]. In [41], the authors first studied the optimal power allocation

for the all-participate AF (AP-AF) network and then proposed the selection-AF scheme that outperforms the conventional all-participate approach with and without the optimal power allocation. The problem of all the work mentioned above is that the practical implementation problem is not considered. To address the practical relay selection problem, the hybrid-ARQ-based intracluster geographic relaying (HARBINGER), the timer-based single relay selection, the busy-tone-based single relay selection, and the contention-based single relay selection have been proposed in [42], [37], [43], and [44], respectively. We introduce them in the following.

1.3.6.1 HARBINGER

Before the data transmission, the original information is encoded into the codeword which consists of many blocks. Then, the source sends the first block of the codeword. At the destination, if the recovery of the original information is successful, the acknowledgement (ACK) packet is replied back. Otherwise, the relay which is closest to the destination and able to recover the original information is selected to send the second block of the codeword. All nodes are equipped with the GPS receiver. At each relay, besides its own position information, the position information of the source and the destination is also available. If the GPS receiver is not available, the ACK packet transmitted from the destination is exploited to estimate the distance between each relay and the destination. The relay selection period consists of I time slots, where I represents the number of relays. Let r_1 and r_I denote the relay which is closest and farthest to the destination, respectively. If the relay r_i is able to decode the original information, it sends the ACK packet in the time slot i , otherwise it does nothing, where $i = 1, \dots, I$. The relay that is closest to the destination and able to decode original information firstly sends the ACK packet to inform all the other relays that it is selected. Then, it sends the second block of the codeword. The source will send the second block of the codeword if no relay sends the ACK packet during the selection period. However, this relay selection requires that each relay must obtain the distances between itself and the destination and between all other relays and the destination. In [42], how to implement this

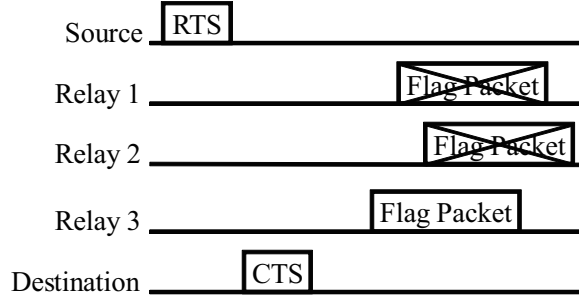

Figure 1.7: An example of the timer-based single relay selection.

requirement is not addressed. Besides, sometimes the other relays can not always successfully overhear the ACK packet. The relay that can not successfully overhear the ACK packet thus does not know there is one relay that has been selected. This is called hidden node problem.

1.3.6.2 Timer-Based Single Relay Selection

Before the data transmission, the source first transmits the Request-to-Send (RTS) packet to the destination. Due to the broadcast nature of wireless channel, each relay j can overhear the RTS packet. Each relay j then uses the received RTS packet to estimate the instantaneous channel h_{sj} of the link between the source and it. After receiving the RTS packet, the destination replies the Clear-to-Send (CTS) packet back to the source. Each relay j can also overhear the CTS packet. Each relay j then uses the received CTS packet to estimate the instantaneous channel h_{jd} of the link between it and the destination. After that, the timer at each relay j is started. The length of the timer at each relay j is inverse to its parameter p_j . There are two methods to have the value of the parameter p_j . In the method 1, $p_j = \min(|h_{sj}|^2, |h_{jd}|^2)$. In the method 2, $p_j = 2|h_{sj}|^2|h_{jd}|^2/(|h_{sj}|^2 + |h_{jd}|^2)$. After the timer is reduced to zero, each relay j then sends the flag packet. The relay with the maximum p_j firstly sends the flag packet. All the other relays back off after overhearing the flag packet. Figure 1.7 illustrates an example of the time-based single relay selection. After the timer of relay 3 is reduced to zero, it sends the flag

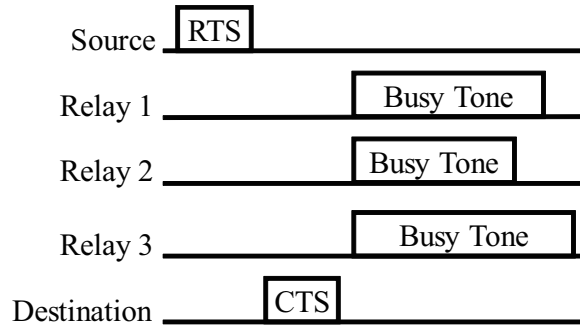

Figure 1.8: An example of the busy-tone-based single relay selection.

packet. By overhearing the flag packet, relays 1 and 2 stop to count down their timers and will not send flag packets. By receiving the flag packet, the source knows that relay 3 is the best relay for the cooperative transmission. However, when the flag packet sent from the relay 3 arrives at relay 1 after relay 1 sends the flag packet or relay 1 cannot overhear the flag packet sent from relay 3, the flag packets from relays 1 and 3 will collide with each other. The later condition is called hidden node problem. When all relays can not overhear from each other, the destination sends a short broadcast packet to all relays after receiving the flag packet.

1.3.6.3 Busy-Tone-Based Single Relay Selection

After receiving the CTS sent from the destination, each relay starts to send the busy tone signal continuously for a period of time. A relay with a better channel condition is assigned with a longer period of time. Each relay listens to the channel after its busy tone transmission finishes. If a relay finds that there is no collision, and the channel is idle, that relay informs the source that it is the best relay. Figure 1.8 illustrates an example of the busy-tone based single relay selection. After sending the busy tone signals, relays 1, 2, and 3 listen to the channel. Relay 2 finds that the collision of the busy tone signals transmitted from some relays happen. Relay 1 finds that there is the busy tone signal transmitted from a relay. Relay 3 find that the channel is idle. Thus, it informs the source that it is the best relay. For wireless ad hoc or sensor networks where energy saving is important, sending the busy tone

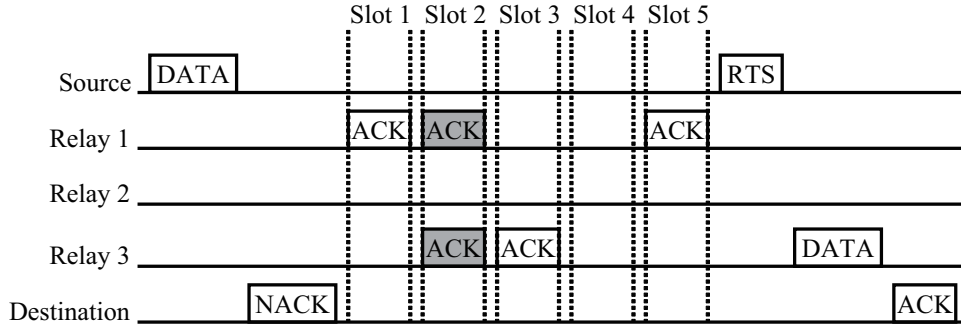

Figure 1.9: An example of the contention-based single relay selection.

signal continuously may cause large energy consumption.

1.3.6.4 Contention-Based Single Relay Selection

Before the data transmission, the source encodes its original information i into the codeword $\mathbf{x}(i)$. The source transmits $\mathbf{x}_1(i)$ which is the transmitted signal of some part of the codeword $\mathbf{x}(i)$. At the first time slot, the received signals at the relay j and the destination can be written as

$$\mathbf{y}_j^{(1)} = h_{sj}^{(1)} \mathbf{x}_1(i) + \mathbf{n}_{sj}^{(1)} \quad (1.16)$$

and

$$\mathbf{y}_d^{(1)} = h_{sd}^{(1)} \mathbf{x}_1(i) + \mathbf{n}_{sd}^{(1)}, \quad (1.17)$$

respectively, where $h_{sj}^{(1)}$ and $h_{sd}^{(1)}$ represent the Rayleigh fading coefficients of the channel between the source and relay j and between the source and the destination, respectively, at the first time slot, and $\mathbf{n}_{sj}^{(1)}$ and $\mathbf{n}_{sd}^{(1)}$ are additive white Gaussian noise with variance N_0 at the first time slot. At the destination, if the recovery of the original information i is successful, the ACK packet is replied back to the source. Otherwise, as shown in Fig. 1.9, the Negative Acknowledgement (NACK) packet is sent. After receiving the NACK packet, each relay uses it to estimate the channel gain between the destination and itself. If the channel gain is higher than a threshold η^{con} , each relay starts to send the ACK packet containing its address back to the source with a probability p^{con} continuously for k times. Otherwise, each relay

remains quiet. Between any two consecutive transmissions of the ACK packets, a guard interval with the length of the propagation delay of the network is inserted to prevent collisions. During each slot, if only one ACK packet is received, source will memorize the address contained in it. In other cases, the multiple ACK packets collide with each other or all the relays do not send the ACK packet. If no address exists, the source will send the signal again. If more than one address exists, the source randomly selects one relay candidate to join the cooperative transmission. In the example shown in Fig. 1.9, the ACK packets sent from relays 1 and 3 collides with each other in time slot 2, but the source still successfully receives the ACK packets sent from relay 1 in time slots 1 and 5 and the ACK packet sent from relay 3 in time slot 3. Then, the source randomly selects the relay for performing the cooperative transmission from survived relays 1 and 3. After the relay is chosen, the RTS packet containing the address of the selected relay (relay 3) is broadcasted to all relay candidates. Then, the selected relay transmits the signal $\mathbf{x}_2(i)$ to the destination. The received signal at the destination in the second time slot can be expressed as

$$\mathbf{y}_d^{(2)} = h_{jd}^{(2)} \mathbf{x}_2(i) + \mathbf{n}_{jd}^{(2)}, \quad (1.18)$$

where $h_{rd}^{(2)}$ represents the Rayleigh fading coefficient of the channel between relay j and the destination at the second time slot, and $\mathbf{n}_{rd}^{(2)}$ is an additive white Gaussian noise with variance N_0 . The destination will combine the received signal with the one transmitted previously from the source and recover the original signal. If the decoding is successful, the ACK packet is replied back to the source.

1.3.7 Cooperative Routing Schemes

Cooperative transmissions can also be used at upper layers such as the combination of cooperation and routing algorithms. The authors in [45] first addressed the concept of cooperative routing which exploits Wireless Broadcast Advantage (WBA) to realize Wireless Cooperative Advantage (WCA). The WBA indicates that the information sent from the source can also be received by other nodes locat-

ing in the transmission range of the source due to the broadcast nature of wireless channel. The WCA indicates that multiple nodes obtaining the same information cooperatively transmit the information through independent channels to other nodes to achieve energy saving. In [45], a dynamic-programming-based algorithm is also proposed to find the energy minimized route. However, it is NP hard. As a result, the authors proposed two centralized heuristic algorithms: cooperation along the minimum energy non-cooperative path (CAN-L) and progressive cooperation (PC-L). In [46], the authors propose the Cooperative Shortest Path (CSP) algorithm which combines the Dijkstra's algorithm with cooperative diversity. In [47], heuristic cooperative routing along truncated non-cooperative route (CTNCR) and source node expansion routing (SNER) are proposed to select the minimum power route subject to the requirement of the fixed transmission rate. It is assumed that the perfect channel information is obtained by both the transmitter and receiver by using a centralized method. In [48], the authors propose relay-by-flooding, relay-assisted routing, and relay-enhanced routing. In the relay-by-flooding, the flooding and multiple hops are used to propagate the message from the source to the destination. In the relay-assisted routing, first, a route is established, and then, the nodes that are associated to the route are used to perform the cooperative transmission. In the relay-enhanced routing, nodes are selected and added to a pre-selected route to exploit cooperative diversity to improve the performance. Node are selected based on local information such that there is no large increase of complexity. Instead of the energy minimization, [49] presents the cooperative energy aware routing algorithm which maximizes the network lifetime. In [50], for the decode-and-forward cooperative coding, the nearest neighbor algorithm (NNA), the nearest neighbor set algorithm (NNSA), and the maximum sum-of-received-power algorithm (MSPA) were proposed to find the rate maximized route. On a pre-defined route, in [51], the energy aware power allocation strategies among the cooperatively transmitting nodes were addressed, and the performance was evaluated in terms of network lifetime.

Although many cooperative routing schemes have been proposed, in most of

them, the shortest route is first found, and then, the cooperative route is constructed based on the found shortest route. The problem of implementing in this way is that the cooperative diversity cannot be fully exploited because the optimal cooperative route may be totally different from the shortest one. Another problem is that it is difficult to implement most of the schemes in wireless networks where there is no centralized infrastructure because a central unit is necessary to collect global information of the network for selecting the best route.

1.4 Cognitive Radio Communications and Networking

1.4.1 Introduction

Due to highly developed wireless, semiconductor, and material technologies, low-cost wireless mobile devices with capabilities of providing high QoS becomes more and more popular. This popularity imposes many challenges on design and management of wireless mobile networks. One of these challenges is the scarcity problem of the limited radio spectrum resource. Conventionally, spectrum regulators adopted the fixed spectrum access (FSA) strategy to manage the usage of the spectrum resource. In FSA, the spectrum is allocated to be used by licensed users. Other users cannot use the allocated spectrum even the licensed users are not using it. Adopting the FSA strategy makes the scarcity problem more serious when the population of wireless users significantly increase. On the other hand, recent results of the measurement of the spectrum utilization indicate that a large portion of the licensed spectrum is rarely used, and the spectrum scarcity is largely caused by the inflexible spectrum allocation strategy. Thus, it is necessary to develop flexible spectrum access technologies to improve the efficiency of the spectrum utilization.

Dynamic Spectrum Access (DSA) [52], [53] has been recognized as a promising technology to improve the efficiency of the spectrum utilization. Users for accessing the spectrum are divided into two groups: primary users (PUs) and cognitive users (CUs). The CUs are equipped with the Cognitive Radio (CR) techniques to sense and learn the surrounding radio environments. The spectrum is allocated to the

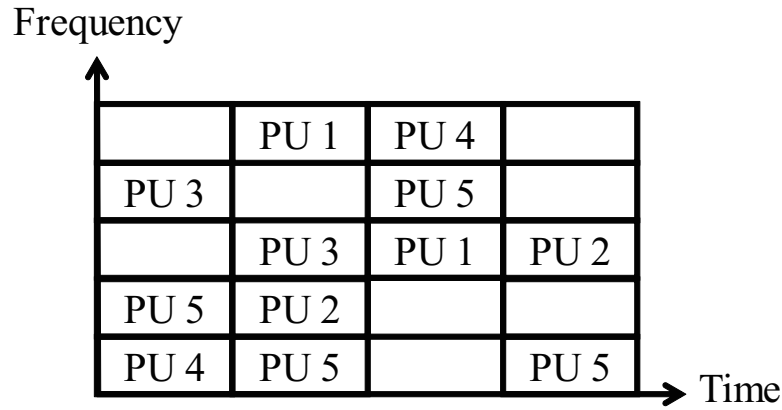

Figure 1.10: Overlay spectrum access.

PUs, and they have the first priority to use it. However, when the PUs are not using the allocated spectrum, the CUs can also use it. This access method is referred as the overlay access [54] or opportunistic spectrum access. Figure 1.10 illustrates the overlay spectrum access. There are five PUs using the allocated spectrum. They are assigned to different frequency bands in different time slots according to the specific resource allocation policy. However, some frequency bands in some time slots are not used by any PU. These used spectrum slots are called spectrum holes. The CUs need to use the signal detection technique to find them for transmitting data. However, an increase of the implementation complexity of the CU is caused by requiring the signal detection technique. In addition, the CU must be able to monitor the whole spectrum and quickly terminate its data transmission when the PU returns to use the spectrum. This requirement makes the design of this access method challenging. Another problem is that when the high primary traffic occurs, the number of unused spectrum holes becomes small.

In addition to the overlay spectrum access that exploits spectrum holes, the PUs and CUs can use the spectrum concurrently. This access method is referred as underlay access [54] or spectrum sharing. In the underlay access, the primary and the cognitive transmissions occur simultaneously at the specified spectrum slot that belongs to the PUs. To achieve this coexistence, the transmission power of the cognitive source (CS) must be lower than a certain threshold such that the QoS

requirement of the primary transmission is satisfied.

To implement DSA in cognitive radio networks (CRNs), the physical (PHY), MAC, and network layers have different functionalities [55]. In the PHY layer, not only the spectrum sensing techniques but also the environmental learning techniques are necessary. The CUs employ spectrum sensing techniques to efficiently search the available spectrum holes and quickly terminate their data transmissions when the PUs restart to use the spectrum. The environmental learning techniques allow the CUs to learn the knowledge of the surrounding environment such as the positions of the PUs, the channel gain, and the channel state information. By exploiting these information, the transceiver of the CU optimizes its parameters to achieve the overlay or underlay spectrum access. In the MAC layer, the sensing scheduling and the spectrum-aware MAC are required to schedule the sensing operation and control the CUs to access available spectrum holes, respectively. These two functions are jointly coordinated by a controller. In the network layer, spectrum aware routing protocols need to be designed to carefully consider various aspects such as the mobility, the PU activity, the QoS control, the route maintenance, and the topology changing. Finally, due to the interactions between these layers, a cross-layer approach for managing all the functions is necessary to allow the CUs to efficiently use the spectrum resources.

1.4.2 Routing Schemes in CRNs

The main challenging task of routing for the CUs in CRNs is how to let the CUs be aware of the spectrum knowledge because the spectrum awareness significantly affects the operations of the route discovery, the next node selection, the route maintenance, etc. Basically, there are two ways. One is that there is a central control unit collecting all the spectrum usage information, and the CUs can access that unit to obtain the global spectrum information of the network. This approach achieves high performance that comes at the cost of large overhead of information exchange. The other one is that each CU obtain the spectrum information locally by distributed or local sensing operation. This approach degrades the performance to

have a lower complexity for practical implementation. As a result, routing schemes in CRNs can be mainly categorized into two folds: with full spectrum knowledge and with local spectrum knowledge. We describe them in the following.

1.4.2.1 Routing Schemes with Full Spectrum Knowledge

Recently, federal communications commission (FCC) promoted spectrum data bases collecting the spectrum information to let the CU opportunistically exploit the spectrum below 900 MHz and in the 3 GHz bandwidth [56]. By accessing spectrum data bases, each CU can obtain the full spectrum knowledge to decide the channel for data transmissions.

Classical routing schemes use graph abstraction and route calculation to select the route for wireless multihop networks. Graph abstraction exploits the logical graph to represent the physical networks topology. A graph structure associated with the number of nodes, the number of edges, and the weights assigned to all edges is generated. Route calculation stands for searching a route between the source and the destination from the generated graph structure. Mathematical programming tools are used for route calculation. We describe various routing schemes with full spectrum knowledge in the following

- Layered-Graph Approach: In [57], [58], the authors propose to jointly consider the channel assignment and routing in semi-static multihop CRNs. The routing design for CUs can be statically treated because it is assumed that the dynamics of the PU activity is low. A multiple-layered graph structure is constructed. The number of layers equals to the number of available channels. Each CU is denoted by multiple nodes that locates in their associated layers. After the graph structure is constructed, searching a route from the source to the destination in the graph structure can solve the channel assignment and routing problem. In [58], based on the calculation of shortest routes, the author proposes a path-centric route calculation algorithm. Although the multiple-layered graph approach can deal with the channel assignment and

routing problem, the global network information is required to construct the graph structure. This approach suffers from large signaling overhead when the network size is large. In addition, because the proposed route calculation is a greedy based approach, the found route is suboptimal.

- **Colored-Graph Approach:** The authors in [59] propose the colored-graph approach to construct the graph structure. A CU is denoted by a vertex. Two vertices are connected by multiple edges that represents the available channels. The number of edges equals to the number of available channels. The method in [58] is used to implement the route calculation algorithm. The disadvantages of this approach is same as those of the layered-graph one.
- **Conflict-Graph Approach:** In [60], the authors decouple the channel assignment and routing problems. A centralized matching algorithm using the conflict-graph is proposed to find the best combination of the routing and the channel assignment. The global network information is necessary, and thus, this approach has the disadvantage of large signaling overhead when the network size is large.
- **Optimization Approach:** By obtaining the global network information and spectrum availability, optimization algorithms can be exploited to find routes in CRNs. The authors in [61], [62] focus on the design of efficient spectrum sharing. A mixed integer non-linear programming (MINLP) formulation is proposed to maximize the spectrum reuse factor. This maximization is equivalent to the minimization of the overall bandwidth usage. Major aspects including link capacity, interference, and routing are considered. This approach allows the packet to be routed through multiple routes. However, in packet switched networks, it is difficult to realize this approach. A linear relaxation is applied to the MINLP formulation, and the resulting formulation can be solved in polynomial time. Although the proposed scheme provides the nearly optimal solutions, it requires to obtain the global network information.

1.4.2.2 Routing Schemes with Local Spectrum Knowledge

Although routing schemes with full spectrum knowledge can provide the upper bound of the performance, it is difficult to implement them in real networks due to the large signaling overhead caused by the collection of the global network information. The practical approach is that the spectrum knowledge is obtained in a distributed manner. In the following, we describe various routing schemes that locally manage the radio resource based on the partial network information.

- **Minimum Power Routing:** In [63], the authors propose to find the route with the minimum weight for cognitive wireless ad hoc networks. The system is divided into operation system and communication system. For accessing different wireless systems such as cellular and WLANs, different wireless interfaces are used. The operation system is in charge of deciding the wireless interface at a given period. The CUs communicate with each other by using the common link control radio (CLCR) to perform cognitive radio functionalities. The neighbor discovery and route discovery and establishment are the main purposes of using CLCR. A route with the minimum routing weight based on the required transmission power is locally found. However, no route maintenance is proposed to correspond to the PU activity. In addition, this scheme is insufficient for dealing with challenges of CRNs because only the power minimization is considered.
- **Minimization of Bandwidth Footprint:** The scheduling, power control, and routing problem are jointly considered by a distributed scheme proposed in [64]. The routing is operated based on the metric of the bandwidth footprint product (BFP). The footprint denotes the interference area associated with a given transmission power. A node use different transmission power to transmit in various frequency bands. Thus, each frequency band has its corresponding footprint. The objective is to minimize the sum of BFPs of all nodes. The link scheduling, power allocation, and route selection are preformed by a conservative iterative procedure (CIP) and an aggressive iterative procedure (AIP).

Although the upper bound of the MINLP formulation can be approached by the iterative operation, the available spectrum is not allowed to be changed during the iterative operation.

- **Routing with Controlled Interference:** In [65], the authors address the routing problem for CRNs where the CUs adopt the underlay access strategy. In such networks, the transmission power of the CU must be lower than a certain threshold in order to satisfy the QoS requirement of the PU. Consequently, subject to the QoS requirement of the CU, the CU has a maximum transmission distance. The authors derive this maximum transmission distance, and proposed two routing algorithms: nearest-neighbor routing (NNR) and farthest neighbor routing (FNR). In FNR, among the nodes in a defined sector with a radius equaling to the maximum transmission distance of the cognitive sender, the node that is farthest away from the cognitive sender is selected as the cognitive receiver. On the other hand, the node that is closest to the cognitive sender is selected as the cognitive receiver. Simulation results show that FNR has better performance in terms of the reliability and channel utilization, and NNR has better performance in terms of energy efficiency. Although the performance in terms of various QoS metrics is investigated, only the static PU activity is considered.
- **Delay Based Schemes:** Delay is an important metric for designing routing schemes for multimedia applications. In [66]-[69], delay-aware routing schemes are proposed. In addition to the classical delay parameters such as the transmission and propagation delays, new delay parameters need to be considered. They are the switch and medium access delays. The switch delay stands for the time required for the CU to switch from one frequency band to another. The medium access delay denotes the time spent by the medium access method employed in a frequency band. A newly defined queueing delay also needs to be considered. It is based on the transmission capacity of the CU transmitting in a frequency band.

- **Throughput Based Schemes:** The authors in [70] propose the spectrum aware mesh routing (SAMER) to consider both the long term and short term spectrum availability. The route with higher spectrum availability is used to relay data. First, periodically collected global network information is used to search candidate routes, and each candidate route is associated with the path spectrum availability (PSA) metric that can be calculated as the throughput. The route with the highest PSA metric is used to opportunistically relay data. In [71], ROSA protocol is proposed to exploit spectrum opportunities to find the route that maximizes the spectrum utility. The spectrum utility is defined as the maximum differential backlog.
- **Link Quality and Stability Based Schemes:** In CRNs, the set of available channels of a CU usually changes due to the dynamic activity of the PU, and the change between two CUs may be correlated or uncorrelated. As a result, the proposed solutions must be able to deal with the problem of the disconnection of the route due to the presence of the PU activity. In [72], spectrum-aware routing (SPEAR) is proposed to exploit the spectrum heterogeneity to maximize the throughput by joint considering the spectrum availability, link quality, and time schedule of the flow. In [73], the authors propose spectrum tree based on demand routing protocol (STOD-RP) to cooperatively consider the route selection and spectrum decision. The handoff scheduling and routing are considered in the algorithm proposed in [74]. The authors show that minimizing latency of spectrum handoff is a NP-hard problem and developed a centralized and a distributed heuristic algorithms. In [75], the link stability that is associated with the overall route connectivity is considered, and a routing scheme called Gymkhana is proposed to delivery information by using the routes that do not go through the area where the stable and high connectivity are not guaranteed. In [76], the authors propose a route stability based routing protocol. The route stability is newly defined based on the route maintenance cost that denotes the efforts spent on maintaining the end-to-end connectivity.

In [15], the spectrum aware routing for cognitive ad-hoc networks (SEARCH) routing protocol is proposed. The mobility of the CU is considered, and the PU avoidance is exploited to select the route and channel. The greedy forwarding is used to select the next hop node. Multiple routes are found, and the destination combines them to construct a route that minimizes the number of hops.

- Probabilistic Schemes: Due to the difficulty of obtaining exact activities of PUs, spectrum aware routing decisions can be made in a probabilistic manner. The authors in [77] propose a routing scheme that exploits a probabilistic metric to find a route that satisfies the given bandwidth demand. The probabilistic metric is defined as the probability distribution of the interference received at the CU in a channel. The interference is caused by transmissions of PUs.

1.5 Positions, Contributions and Outline of This Dissertation

Figure 1.11 summarizes positions and contributions of this dissertation. For cooperative transmissions, several hybrid relaying schemes have been proposed to adaptively employ different relaying protocols to improve the system performances. However, most of them treated the problem from the perspective of theoretical analysis and ideally assumed that the CSIs are available. The practical problems concerned to the implementation of those ideas have not been addressed. Therefore, in Chapter 1, we propose a practical IEEE 802.11 based approach to implement the hybrid relaying function and the semi-distributed relay selection in an ad hoc network where each relay candidate adaptively employs the AF or the DF or the no relaying (direct transmission). Unlike the previous works that selected the relaying protocol based on only the channel condition of the source-to-relay link, each relay candidate adopts the relaying protocol, which minimizes the theoretical BER based on the estimated CSIs of the source-to-relay, the relay-to-destination, and the source-to-destination links.

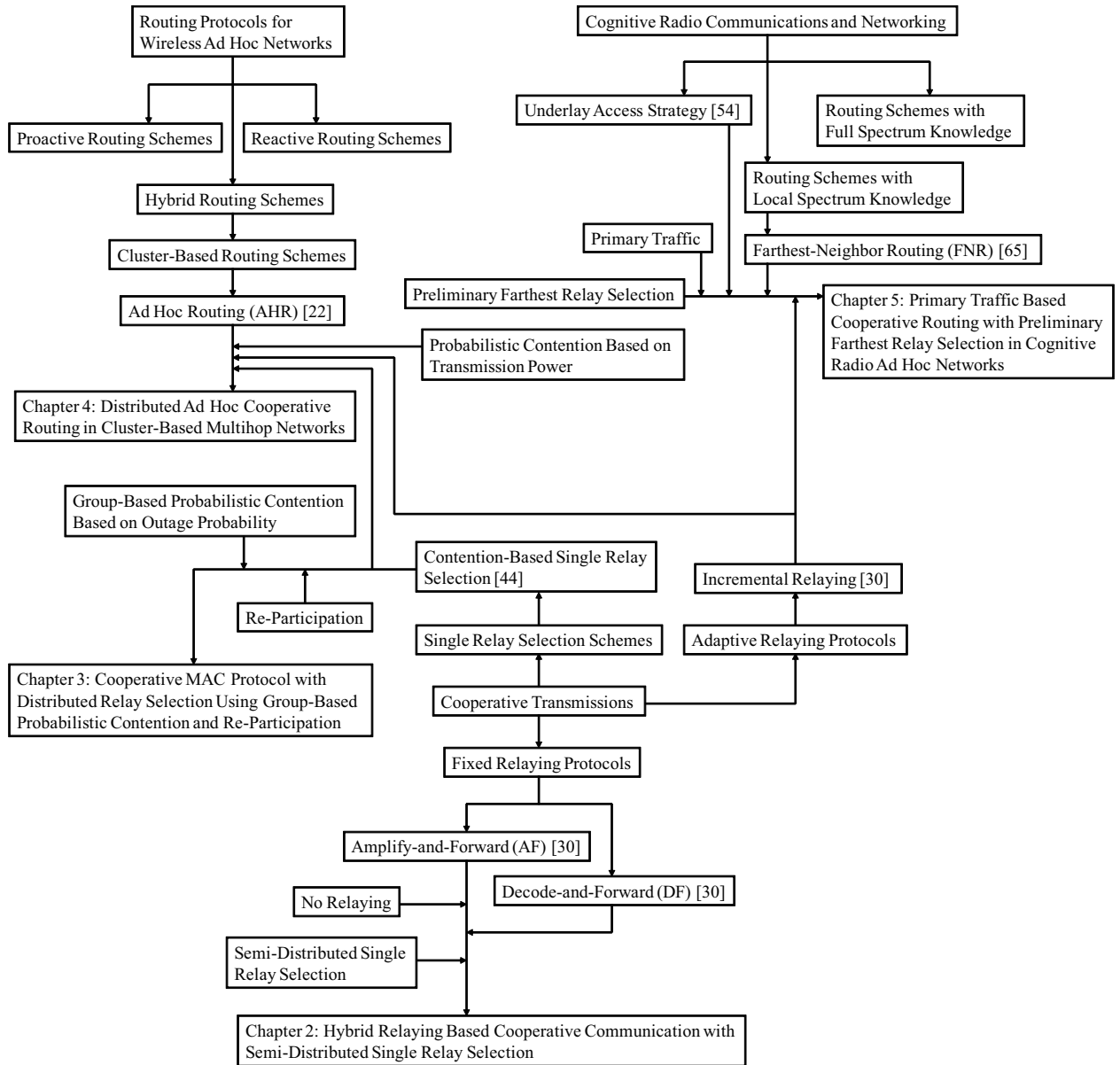

Figure 1.11: Positions and contributions of this dissertation.

Relay selection for cooperative transmissions is another important issue due to its large effects on the system performance. Although several practical relay selection schemes have been proposed, many problems of them still remain unsolved. In [44], by using probability based ACK packet contention, the authors propose an opportunistic relay selection scheme that aims at selecting the relay with the best channel condition. Each relay candidate compares its channel gain with a predefined threshold, and if the channel gain of the relay candidate is higher than the predefined threshold, the relay uses a probability to send the ACK packet back to the source. This kind of contention is repeated for a number of times. In each contention, if a relay candidate survives, the source will memorize its information. After the contention, the source randomly selects one relay for resending the overheard data from the source to the destination. If no relay exists, the source will resend the data to the destination. However, there are two problems in this conventional scheme. First, in each contention, all the relay candidates with the channel gains that are higher than the threshold participate. When the number of relay candidates is large, high collision probability of ACK packets occurs, and therefore, large transmission power of ACK packets is wasted. Second, each relay candidate uses the same probability to send ACK packets in each contention. This means that the same opportunity is given to each relay candidate without considering the channel gain of each relay candidate. However, the relay candidate with higher channel gain should use a higher probability to send the ACK packet to gain more opportunity of being selected.

To overcome the above problems, in Chapter 3, we propose a MAC protocol that exploits group-based probabilistic contention and re-participation to implement distributed relay selection. Our aim is to select the relay with the minimum outage probability. By dividing the relay candidates into multiple groups, those ones with lower outage probabilities contend for being selected as the relay earlier. In addition, in one contention slot, a higher contention probability is assigned to a relay candidate with a lower outage probability, and a relay that does not contend can contend in the next contention slot. Once a relay candidate survives, the contention process

is terminated. As a result, compared to the conventional scheme, the proposed one improves the outage probability and reduces the number of ACK packets for contention and the number of contention slots.

In wireless ad hoc networks, practical routing protocols have been proposed to reduce the high computational complexity of optimal ones. However, this complexity reduction comes at the cost of the performance degradation. In cluster-based multihop networks, considering energy minimized routing, the optimal route can be discovered by searching all possible routes from the source to the destination [22]. However, this searching requires that the CSI of all links between any two nodes is available at a central controller. In order to reduce the implementation complexity, AHR which performs in a hop-by-hop fashion is also proposed in [22]. However, an increase in the required transmission power occurs due to the complexity reduction. Besides, when the conventional distributed relay selection is applied to implement AHR, the receiver selection error causes another increase in the required transmission power. As a result, in Chapter 4, we propose Ad Hoc Cooperative Routing (AHCR) that exploits the cooperative transmission to reduce the difference between the required transmission power of AHR and that of optimal routing. Besides, we present Distributed Ad Hoc Cooperative Routing (DAHCR) scheme 1 that exploits the cooperative transmission to reduce the difference between the required transmission power of distributed ad hoc routing (DAHR) and that of AHR. After that, the problem of DAHCR scheme 1 is addressed, and DAHCR scheme 2 is proposed. In these proposed approaches, the sender selects the receiver and the relay in a distributed way, and the cooperative transmission is performed.

When practical routing protocols are operated by using the underlay access strategy in a cognitive radio environment, the coexistence of primary and secondary users also degrade the performance. In CRAHN, FNR algorithm using underlay access has been proposed to find a multihop route from the CS to the cognitive destination (CD) [65]. In FNR, for each hop, first, the maximum transmission distance of the cognitive relay is calculated, and an area is specified. Then, from the cognitive nodes in the specified area, the cognitive node that is farthest from the

cognitive relay that sends data is selected as the cognitive relay that receives data. However, in FNR, the primary traffic pattern is not considered, and it is assumed that the primary source (PS) is always transmitting data to the primary destination (PD).

When the primary traffic pattern is considered in FNR, first, the status of the primary transmission is detected, and if the PS is transmitting data to the PD, the maximum transmission distance of the cognitive relay subject to the QoS requirement of the primary transmission is calculated. If the PS is not transmitting data to the PD, the maximum transmission distance of the cognitive relay equals to the maximum transmission distance subject to the QoS requirement of the cognitive transmission. For each hop, among the cognitive nodes in the area identified by the maximum transmission distance, the cognitive node that is farthest from the cognitive relay that sends data is selected as the cognitive relay that receives data. In this dissertation, we call this relaying algorithm primary traffic based farthest neighbor routing (PTBFNR).

In conventional PTBFNR, the transmission distances of the cognitive relays become shorter due to the lower transmission power caused by the coexistence of the primary and cognitive transmissions. Therefore, the number of cognitive relays on the route from the CS to the CD is increased. For a multihop route, the end-to-end reliability can be defined as the probability of the successful reception of a packet at all cognitive relays on the route and the CD and can be given by [65]

$$\rho = \prod_{i=1}^K \beta_c^{(i)}, \quad (1.19)$$

where K denotes the number of cognitive relays on the route between the CS and CD, and $\beta_c^{(i)}$ represents the probability of the successful reception of a packet at the i th cognitive relay interfered by the PS. From (1), we can know that a large K or small $\beta_c^{(i)}$ will degrade the end-to-end reliability significantly. The increase of the number of cognitive relays may result in a large K , and thus, a lower end-to-end reliability is caused.

To improve the end-to-end performance of PTBFNR, in Chapter 5, we develop

a primary traffic based routing algorithm with cooperative transmission (PTBR-CT). It uses the successful reception probability of a packet as the routing metric and enlarges the shorter transmission distances of the cognitive relays found by PTBFNR to reduce the average number of cognitive relays. When the PS transmits data to the PD in the current time slot, a cognitive node that is farthest away from the cognitive sender in the reliability constrained area is selected as the cognitive relay in advance. The incremental relaying based cognitive cooperative transmission is performed when the PS still transmits data to the PD in the next time slot. Thus, the shorter hop transmission distance caused by the coexistence of the primary and cognitive traffic is extended. Tables 1.1 and 1.2 give the outline of our work.

Table 1.1: Outlines of Chapters 2 and 3.

Chapter 2	Topic	Hybrid Relaying Based Cooperative Communication with Semi-Distributed Single Relay Selection
	Problem of conventional schemes	Practical problems concerned to the implementation have not been addressed.
	Proposed scheme	A practical IEEE 802.11 based approach is proposed to implement the hybrid relaying function and the semi-distributed relay selection in an ad hoc network where each relay candidate adaptively employs the AaF or the DaF or the no relaying.
	Effects of the proposed scheme	The proposed hybrid relaying scheme provides performance gains over the AF, the DF relaying, and the direct transmission.
Chapter 3	Topic	Cooperative MAC Protocol with Distributed Relay Selection Using Group-Based Probabilistic Contention and Re-Participation
	Problem of the conventional scheme	When the number of relay candidates is large, high collision probability of ACK packets occurs, and therefore, large transmission power of ACK packets is wasted. In addition, the same opportunity is given to each relay candidate without considering the channel gain of each relay candidate.
	Proposed scheme	The group-based probabilistic contention and re-participation are exploited to implement the distributed relay selection.
	Effects of the proposed scheme	The outage probability is improved, and the number of ACK packets for contention and the number of contention slots are reduced.

Table 1.2: Outlines of Chapters 4 and 5.

Chapter 4	Topic	Distributed Ad Hoc Cooperative Routing in Cluster-Based Multihop Networks
	Problem of conventional schemes	The required transmission power is increased due to the complexity reduction and receiver selection error.
	Proposed scheme	The cooperative transmission is exploited to reduce the required transmission power. A higher contention probability is assigned to a node with lower required sender transmission power. Besides, the difference between any two qualified contention probabilities is increased by re-distributing all qualified contention probabilities. Thus, the node with the highest contention probability will have more opportunity to be selected.
	Effects of the proposed scheme	Simulation results show that compared to conventional schemes, proposed routing schemes reduce the required transmission power but increase the complexity.
Chapter 5	Topic	Primary Traffic Based Cooperative Routing with Preliminary Farthest Relay Selection in Cognitive Radio Ad Hoc Networks
	Problem of the conventional scheme	The transmission distance of the cognitive relay is shortened by the coexistence of the primary and secondary traffic, and thus the number of cognitive relays on the multihop route is increased. The end-to-end reliability degrades due to the increased number of cognitive relays on the multihop route.
	Proposed scheme	The successful reception probability of a packet is used as the routing metric. The cooperative transmission is exploited to enlarge shorter transmission distances when the primary traffic occurs in two successive time slots.
	Effects of the proposed scheme	The proposed scheme outperform the conventional one in terms of the average end-to-end reliability, throughput, required transmission power, and transmission latency.

Chapter 2

Hybrid Relaying Based Cooperative Communication with Semi-Distributed Single Relay Selection

2.1 Introduction

Although several hybrid relaying schemes have been proposed to adaptively employ different relaying protocols to improve the system performance, most of them treated the problem from the perspective of theoretical analysis and ideally assumed that the channel state information (CSI) is available. How to implement those ideas has not been addressed. Therefore, in this chapter, we propose a practical IEEE 802.11 based approach to implement the hybrid relaying function and the semi-distributed relay selection in an ad hoc network where each relay candidate adaptively employs the amplify-and-forward (AF) or the decode-and-forward (DF) or the no relaying (direct transmission). In the conventional centralized scheme, the source decides the relaying protocol of each relay candidate and selects the relay node based on the local and global minimized theoretical bit error rate (BER), respectively. As a result, the source must obtain the global CSI including signal-to-noise ratios (SNRs) of links between the source and all relay candidates, between all relay candidates and the destination, and between the source and destination. In the proposed semi-distributed scheme, by exploiting the multicast request-to-send (RTS) and the clear-to-send (CTS) signaling, each relay candidate not only estimates the channel conditions of its links to the source and the destination but also obtains the channel condition of the source-to-destination link. Therefore, no global CSIs are required at the source, the relay, and the destination. By utilizing the BEACON packet, the achieved theoretical BER of each relay candidate is sent back to the source. Then, the relay candidate with the minimum theoretical BER is chosen by the source to employ the predetermined relaying protocol to join the cooperative

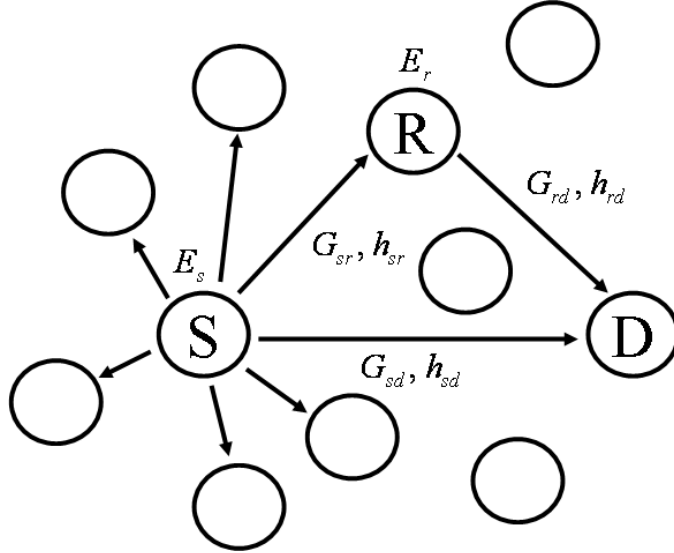

Figure 2.1: An example of cooperative communication.

communication. We investigate the performances of the proposed scheme, the AF, the DF relaying, and the direct transmission (no relaying) by computer simulations.

This chapter is organized as follows. In Section 2.2, we describe the transmission model. The proposed approach is presented in Section 2.3. In Section 2.4, the performance of our proposed approach is evaluated. This chapter is concluded in Section 2.5.

2.2 Transmission Model

We consider an ad hoc network where each source tries to find a partner located in its transmission range to help to relay the overheard information to the destination. An example is shown in Fig. 2.1. Each node is assumed to have a single antenna due to size and power constraint. All the signals are modulated by the binary phase shift keying (BPSK). The effects of the long term free space path loss and short term Rayleigh fading are jointly considered in the channel model of each link. The free space path loss is expressed as:

$$G = \left(\frac{4\pi}{\lambda}\right)^2 \left(\frac{1}{d}\right)^\alpha \quad (2.1)$$

where G denotes the channel gain, λ is the radio wavelength, d represents the transmission distance, and α denotes the path loss exponent. Over one frame interval, we assumed the channel coefficients are static and change independently from one frame interval to another. The whole transmission period is divided into two time slots. In the first time slots, the source sends the data to the destination. Due to the broadcast nature of wireless channel, the same data can also be heard by the the relays located in the transmission range of the source. In the second time slot, the overheard data is processed and forwarded to the destination. The destination uses the Maximal Ratio Combing (MRC) technique to combine the signals transmitted from the source and the relay resulting in a virtual multi-input single-output (MISO) system.

2.2.1 Amplify-and-Forward Relaying Protocol

Normally, in AF, there is no memory for the relay to store received data. Thus, data is amplified and forwarded in only one time slot. However, in AF of cooperative transmission, it is assumed that the relay has the memory to obtain received data in the first time slot and amplify and forward them in the second time slot [30]. With the AF, the relay simply amplifies and forwards the overheard signal to the destination. In the first time slot, the source transmits the signal x and the received signals y_r and $y_{d,1}$ at the relay and the destination can be presented as:

$$y_r = \sqrt{E_s G_{sr}} h_{sr} x + n_{sr} \quad (2.2)$$

$$y_{d,1} = \sqrt{E_s G_{sd}} h_{sd} x + n_{sd} \quad (2.3)$$

where E_s denotes the transmitted energy per bit at the source, G 's represent the channel gains between the source, relay, and destination, h 's represent the Rayleigh fading coefficients, and n 's are zero mean complex Gaussian random variables. In the second time slot, the relay amplifies the received signal y_r and transmits it to the destination. The received signal $y_{d,2}$ at the destination can be formulated as:

$$y_{d,2} = \sqrt{E_r G_{rd}} h_{rd} \alpha y_r + n_{rd} \quad (2.4)$$

where E_r represents the transmitted energy per bit at the relay and α denotes an amplification factor.

At the destination, using the MRC technique to combine the received signals $y_{d,1}$ and $y_{d,2}$, the SNR of the combined signal can be given by:

$$\gamma_d = \gamma_{sd} + \frac{\gamma_{sr}\gamma_{rd}}{\gamma_{sr}\gamma_{rd} + 1} \quad (2.5)$$

where $\gamma_{sd} = G_{sd}E_s\sigma_{sd}^2/N_0$, $\gamma_{sr} = G_{sr}E_s\sigma_{sr}^2/N_0$, and $\gamma_{rd} = G_{rd}E_r\sigma_{rd}^2/N_0$. σ^2 's are variances of the Rayleigh fading coefficients. The theoretical BER of the combined signal at the destination can be obtained as follows:

$$P_b = Q\sqrt{2(\gamma_d)} \quad (2.6)$$

In [32], the authors further derived the theoretical approximation of the above equation. When the signal is modulated by BPSK and the channel suffers from Rayleigh fading, the asymptotic average BER for high SNR can be expressed as:

$$P_b = \frac{3}{16\gamma_{sr}\gamma_{sd}} + \frac{3}{16\gamma_{rd}\gamma_{sd}} \quad (2.7)$$

2.2.2 Decode-and-Forward Relaying Protocol

Generally, for the DF, the operation can be categorized into two ways: fixed and adaptive. With the fixed DF, the received data at the relay is first decoded. No matter on whether the decoding is correct or not, the relay re-encodes and forwards the decoded data to the destination. Contrarily, for the adaptive DF, the relay uses the cyclic redundancy check (CRC) to inspect the correctness of the decoded data and decides whether or not to re-encode and relay it to the destination. In this paper, we consider the adaptive DF that the relay periodically applies the CRC to check the correctness of each B -bit data frame.

In [33], the authors analyzed the theoretical BER performance of the adaptive DF based on quadrature signaling. The BPSK modulation is used and the data transmitted from the source and the relay are combined and detected by the MRC technique and the maximum likelihood (ML) rule, respectively. The asymptotic

average BER for high SNR can be formulated as:

$$P_b = \frac{K_N}{16\gamma_{sr}\gamma_{sd}} + \frac{3}{16\gamma_{rd}\gamma_{sd}} - \frac{3K_N}{64\gamma_{sr}\gamma_{rd}\gamma_{sd}} \quad (2.8)$$

where $K_N = \sum_{n=1}^B (1/n)$ for a B -bit data frame.

2.2.3 No Relaying (direct transmission)

Here, the no relaying (direct transmission) means that the relay does not process and forward the overheard signal to the destination. Only the signal transmitted from the source is received at the destination. When the distance between the source and the destination is short, cooperative communication may not perform better than the direct transmission. Thus, we also consider that no relaying is another option that can be selected by the relay. In the case of BPSK modulation and Rayleigh fading, the theoretical BER of the direct transmission from the source to the destination can be expressed as:

$$P_b = \frac{1}{2} - \frac{1}{2} \sqrt{\frac{\gamma_{sd}}{1 + \gamma_{sd}}} \quad (2.9)$$

2.3 Proposed Approach

In this section, we present our proposed IEEE 802.11 based hybrid relaying scheme with semi-distributed single relay selection. The whole communication procedure consists of four phases: 1) multicast RTS and CTS packets exchange 2) relaying protocol setting 3) semi-distributed single relay selection 4) data transmission which will be described detailedly in the following subsections. A simplified communication procedure is illustrated in Fig. 2.2.

2.3.1 Phase 1: Multicast RTS and CTS Packets Exchange

The idea of multicast RTS was first addressed in [78] which studied the medium access control (MAC) and scheduling problems in rate adaptive wireless local area networks (WLANs). In this chapter, we exploit the multicast RTS and the normal

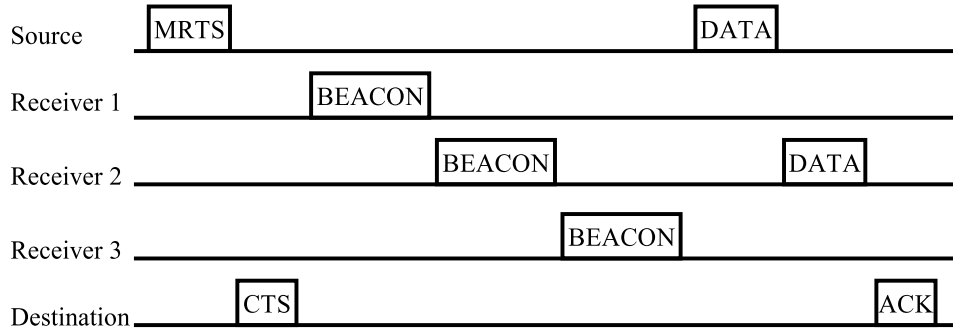

Figure 2.2: Simplified communication procedure.



Figure 2.3: Multicast RTS packet format.

CTS exchange to search the set of relay candidates and estimate the SNR of each link. A multicast RTS packet is illustrated in Fig. 2.3. Due to the nature of ad hoc network, each mobile node always receives the packets transmitted from the surrounding nodes and checks if the received packet belongs to itself or not. Thus, when the source has packets to transmit, it starts to write the addresses of the surrounding nodes into the multicast RTS packet and sends it to the destination. Note that this packet can also be received by the surrounding nodes located in the transmission range of the source due to the broadcast nature of wireless channel. The destination uses the received multicast RTS packet to estimate the SNR of the source-to-destination link and record the result into the CTS packet. Then, the CTS packet is replied back to the source. Similarly, the surrounding nodes near the destination can also receive the CTS packet. Only those nodes that receive both the multicast RTS and CTS packets are selected to be the relay candidates. Then, each relay candidate uses the received multicast RTS and CTS packets to estimate the SNRs of its links to the source and the destination. Note that the SNR of the source-to-destination link is already contained in the received CTS packet. Thus, each relay candidate obtains not only the SNRs of its link to the source and the

destination but also the SNR of the source-to-destination link.

2.3.2 Phase 2: Relaying Protocol Selection

After each relay candidate obtains the SNR values between the source, itself, and the destination, the theoretical BER of applying the AF, the DF, and the no relaying can be calculated according to (2.7), (2.8), and (2.9), respectively. Each relay candidate then selects the relaying protocol, which minimizes the theoretical BER for processing the overheard data.

2.3.3 Phase 3: Semi-distributed Single Relay Selection

After the relaying protocol selection, each relay candidate records the minimized theoretical BER into the BEACON packet and checks itself's order from the previously received multicast RTS packet. Then, the BEACON packets are sent back to the source continuously based on the defined order. By this way, the achievable theoretical BERs of all relay candidates are known at the source. Then, the source selects the relay candidate, which minimizes the theoretical BER from the set of relay candidates to participate the cooperative communication.

2.3.4 Phase 4: Data Transmission

In the first time slot, the source sends the data packet that contains the transmitted information and the selected relay's identification (ID) to the destination. Due to the broadcast nature of wireless channel, the data packet is also heard by the surrounding nodes in the transmission range of the source. Each of these nodes uses the ID contained in the data packet to check if it is selected as the relay. In the second time slot, only the selected relay can employ the predefined relaying protocol to process and forward the overheard data to the destination. At the destination, the received packets from the source and the relay are combined by the MRC technique. Then, the destination replies the ACK packet back to the source if the information can be decoded correctly.

Table 2.1: Simulation Parameters.

parameter	value
simulation area	500m \times 500m
number of nodes	10, 15, and 20
transmission frequency	2.4 GHz
path loss exponent α	3
data frame size B	128 bits
variances of the Rayleigh fading coefficients σ^2 's	1

2.4 Performance Evaluation

The simulation parameters summarized in Table 2.1 are used to investigate the performances of the proposed scheme, the AaF, the DaF relaying, and the direct transmission (no relaying). We assume that the SNR decreases to 0 dB at the place that is 250m far from the transmitter. We generate 1000 random node distributions. For each node distribution, two randomly selected mobile nodes act as the source and the destination.

Figure 2.4 to 2.6 illustrate the location distribution of the selected relays with adopted relaying protocols with different d_{sd} (γ_{sd}). The number of nodes is fixed to 10. Note that each selected relay is associated with a minimum theoretical BER achieved by the AF or the DF or the no relaying. Due to the property of the triangular formed by the source, the relay candidate, and the destination, the selected relays can only be distributed in the pentagon area. From Fig. 2.4, it is observed that the minimum theoretical BER is achieved by the AF at most of the selected relays. However, when d_{sr} is less than 200m and d_{rd} is larger than 200m, the DF dominates and achieves the minimum theoretical BER. In addition, when both d_{sr} and d_{rd} exceed 200m, the minimum theoretical BER is achieved by the no relaying. Simulation results in Fig. 5 reveal that the AF still achieves the minimum

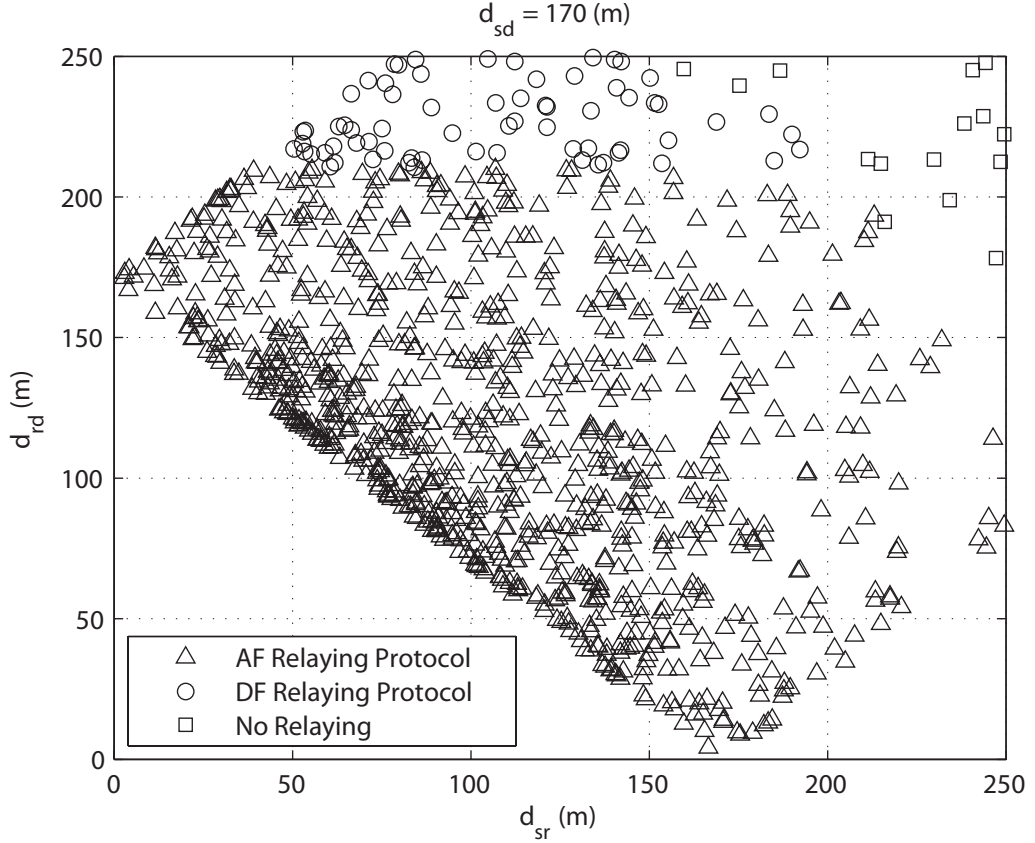

Figure 2.4: Location distribution of the selected relays with adopted relaying protocols with $d_{sd} = 170\text{m}$ ($\gamma_{sd} = 5$ dB).

theoretical BER at most of the selected relays. Besides, the DF still dominates and achieves the minimum theoretical BER when d_{sr} is less than 200m and d_{rd} is larger than 200m. The no relaying achieves the minimum theoretical BER at some selected relays located in the distribution area that d_{sr} and d_{rd} exceed 200m and 150m, respectively. The similar distributions of the AF, the DF, and the no relaying are also presented in Fig. 6. Observing from Fig. 4 to 6, we can conclude the DF and the no relaying dominate and achieve the minimum theoretical BER when d_{rd} exceeds 200m.

The location distributions of the selected relays with adopted relaying protocol with fixed d_{sd} (γ_{sd}) but different number of nodes are similar to Fig. 2.4 to 2.6. Thus, instead of showing the location distribution, we list the number of times that

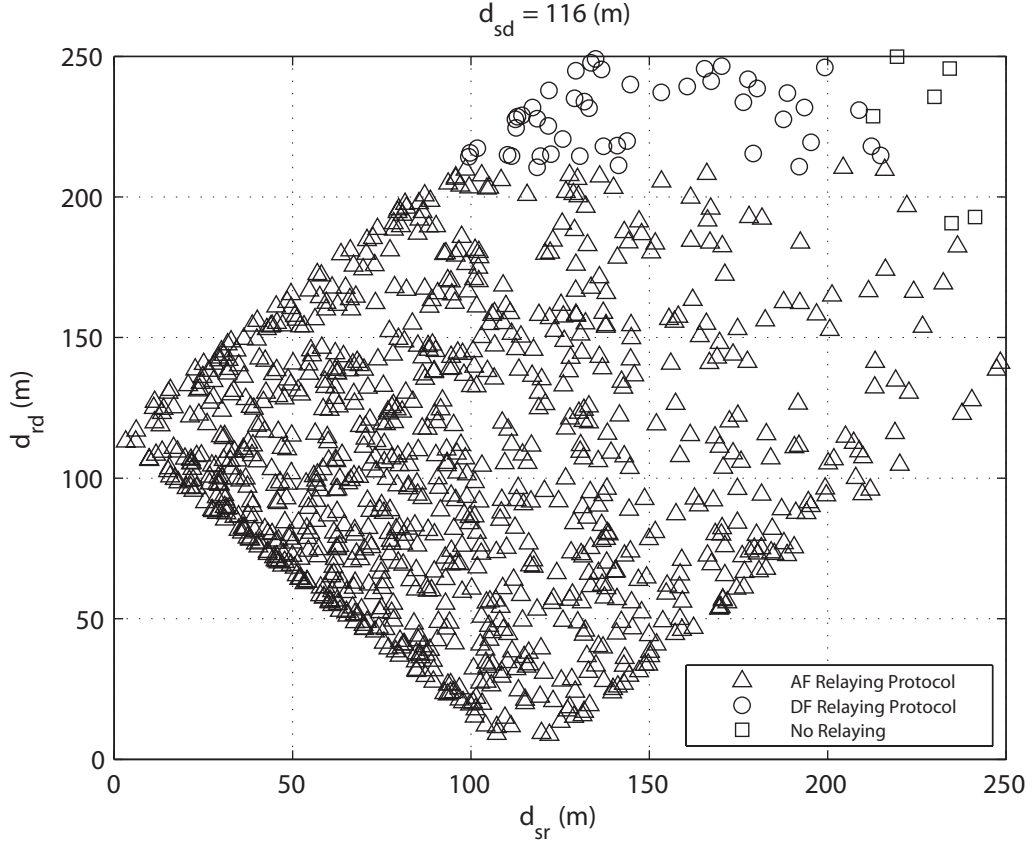

Figure 2.5: Location distribution of the selected relays with adopted relaying protocols with $d_{sd} = 116\text{m}$ ($\gamma_{sd} = 10\text{ dB}$).

various relaying protocols achieve the minimum theoretical BER in Table 2.2. We observe that when the number of nodes increases, the number of times the minimum theoretical BER achieved by the DaF and the no relaying decreases, and that of the AF increases. The reason is that when the number of nodes increases, more relay candidates will adopt the AF due to its larger distribution area. Thus, the larger diversity gain brought by more relay candidates increases the probability that the AF achieves the minimum theoretical BER.

Figure 2.7 compares the BER performances of various relaying schemes for the network of 10, 15, and 20 nodes. The results shown in Fig. 2.7 are the average of over 1000 randomly generated node distributions. At the BER of 10^{-3} for the network of 10 nodes, the proposed scheme outperforms the AF, the DF relaying,

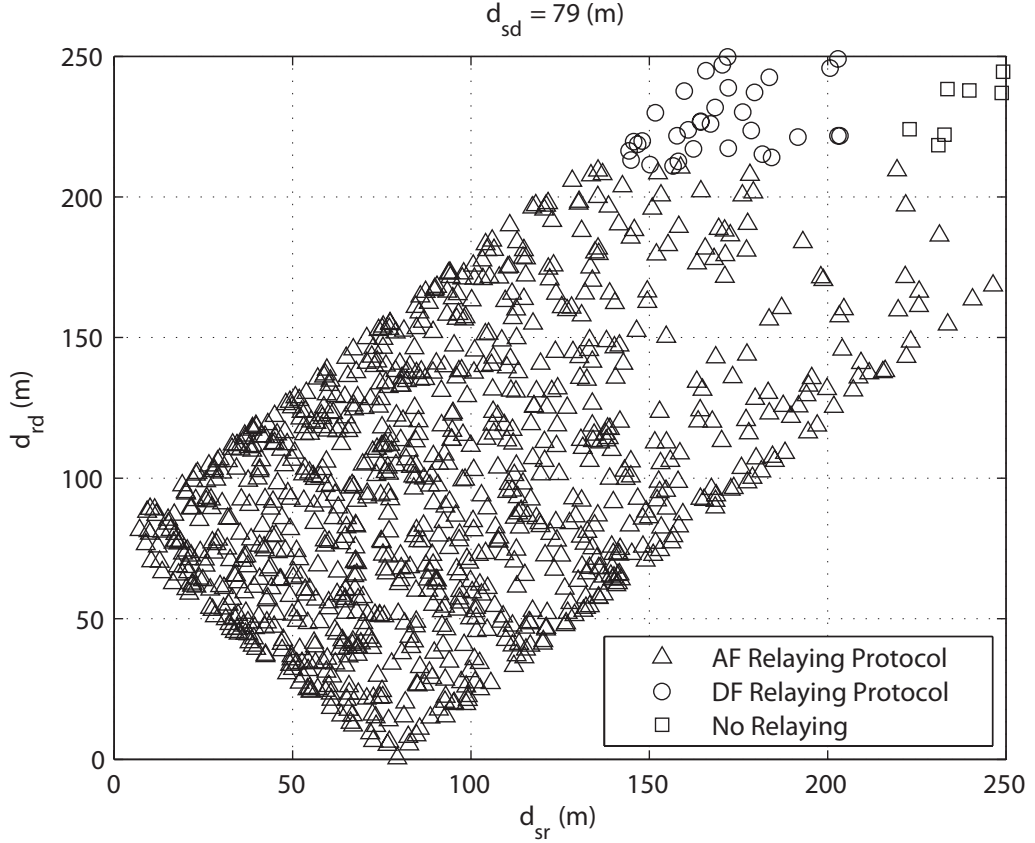

Figure 2.6: Location distribution of the selected relays with adopted relaying protocols with $d_{sd} = 79\text{m}$ ($\gamma_{sd} = 15\text{ dB}$).

and the direct transmission by 0.38, 0.77, and 7.88 dB, respectively. For the same BER, the performance gain of the proposed scheme over the AF, the DF relaying, and the direct transmission is 0.29, 0.96, and 9.81 dB for the network of 15 nodes and 0.29, 0.77, and 10.96 dB, respectively, for the network of 20 nodes.

In the conventional centralized scheme, the source node decides the relaying protocol of each relay candidate and selects the relay node that has the minimized theoretical BER. Therefore, the source must obtain the global CSI by using the feedback method. The global CSIs include SNRs of the source-to-destination, source-to-relay, and relay-to-destination links. Let M denote the number of relay candidates. The amount of the CSI feedback will be $2M + 1$. In the proposed semi-distributed scheme, by exploiting the IEEE 802.11 control frame exchange, each relay candi-

Table 2.2: Number of times that various relaying protocols achieve the minimum theoretical BER with different number of nodes.

number of nodes	AaF	DaF	no relaying
10	917	68	15
15	948	44	8
20	969	27	4

date obtains SNRs of its links to the source and destination and the SNR of the link between the source and destination. Then, each relay candidate calculates the theoretical BER of each relaying protocol and adopts the relaying protocol that has the local minimized theoretical BER. The BEACON packet is used to send the theoretical BER of each relay candidate to the source. Then, the source selects the relay that has the global minimized theoretical BER to perform the cooperative transmission. Therefore, the amount of the theoretical BER feedback is M . Compared to the conventional centralized scheme, the proposed semi-distributed one reduces the amount of the feedback information by $M + 1$.

2.5 Conclusion

We have proposed and investigated a practical hybrid relaying based cooperative communication scheme. Simulation results reveal that the AF achieves the minimum theoretical BER at most of the selected relays. However, when d_{rd} exceeds 200m, the DF and the no relaying dominate and achieve the minimum theoretical BER. Besides, when the number of nodes increases, the number of times the minimum theoretical BER achieved by the DF and the no relaying decreases, and that of the AF increases. Finally, we show that the proposed hybrid relaying scheme provides performance gains over the AF, the DF relaying, and the direct transmission.

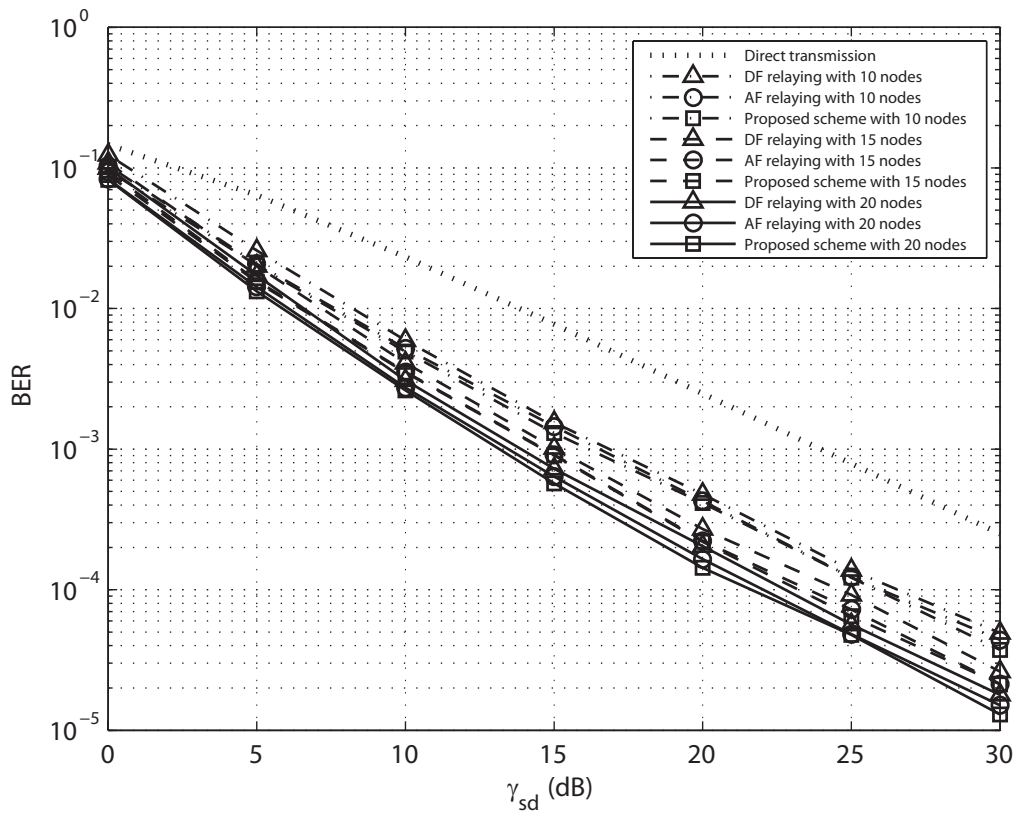

Figure 2.7: BER performances of various relaying schemes for the network of 10, 15, and 20 nodes.

Chapter 3

Cooperative MAC Protocol with Distributed Relay Selection Using Group-Based Probabilistic Contention and Re-Participation

3.1 Introduction

In Chapter 2, the relay is selected in a semi-distributed way. However, when the number of relay candidates is large, the delay caused by the transmissions of the control packets will be long. As a result, in this chapter, we focus on the contention-based relay selection scheme that the delay caused by the transmissions of the control packets is a fixed value. In the conventional approach, large transmission power of control packets is wasted when the number of relay candidates is large. In addition, the relay is selected without considering the channel condition. To overcome these problems, a medium access control (MAC) protocol that exploits group-based probabilistic contention and re-participation is proposed to implement distributed relay selection. The relay candidates contend in a group-by-group way. Each group is defined by a specified range of the outage probability. Each relay candidate finds the group that it belongs to according to its outage probability. The relays in a group with lower outage probability range contend earlier. Each relay in the same group sends the acknowledgement (ACK) packet back to the source based on the probability calculated by the outage probability. A higher contention probability is assigned to a relay candidate with a lower outage probability. In addition, for the relay candidate that does not send the ACK packet in the current time slot, it is allowed to contend one more time in the next time slot by using a probability that is higher than those of the other relay candidates. After one group contention, if only one relay candidate sends the ACK packet back to the source, that relay is selected, and the source includes this information in the request-to-send (RTS) packet and sends it to the selected relay. This RTS packet also

terminates the group contention to avoid unnecessary transmissions of ACK packets for contention. Simulation results show that the proposed scheme improves the outage probability, shortens the contention period, and reduces the number of ACK packets for contention compared to the conventional one.

This chapter is organized as follows. The system model is described in Section 3.1. Section 3.2 introduces the decode-and-forward incremental relaying protocol. The protocol design is presented in Section 3.3. The performance evaluations are described in Section 3.4. Section 3.5 gives the conclusion.

3.2 System Model

We consider a wireless ad hoc network where each node adopts half-duplex mode and is equipped with only one antenna because of the size and the energy consumption constraints. The short term Rayleigh fading is used to model the wireless channel. We assume that during one data packet transmission, the channel coefficients are the same. A relay with the minimum outage probability is selected to assist the source to transmit the data packet to the destination, if the destination can not recover the data packet received at the first time. The relay selection scheme is developed by exploiting the legacy IEEE 802.11 distributed coordination function (DCF) that adopts carrier sense multiple access with collision avoidance (CSMA-CA). We use the outage probability to evaluate the quality-of-service (QoS) of the system. The outage probability is defined as the probability that the receiver fails to decode the received data packet, and this happens when the signal-to-noise ratio (SNR) observed at the receiver is lower than a certain threshold. From [79], we can know that under the Rayleigh fading channel and without any other interferer, the probability that the SNR observed at the receiver is higher or equal to a certain threshold can be calculated as

$$\Pr(SNR \geq \gamma) = \exp\left(-\frac{\gamma N_0}{P_0 d_0^{-\alpha}}\right), \quad (3.1)$$

where γ represents the SNR threshold, N_0 is the noise variance, P_0 denotes the sender transmission, d_0 represents the distance between the sender and the receiver,

and α is the path loss exponent. Therefore, the outage probability can be calculated as

$$p^O = 1 - \exp\left(-\frac{\gamma N_0}{P_0 d_0^{-\alpha}}\right). \quad (3.2)$$

Let $d_{a,b}$ and $h_{a,b}$ represent the distance between node a and node b and the Rayleigh fading coefficients of the wireless channel between node a and node b , respectively. Let $n_{a,b}$ denote the additive noise measured at node b when node a is the sender and be modeled as a zero mean complex Gaussian random variable with variance N_0 .

3.3 Decode-and-Forward Incremental Relaying Protocol

We implement the cooperative transmission by using the decode-and-forward incremental relaying protocol proposed in [30]. Two time slots are required for the cooperative transmission. Let node S , R , D represent the source, the relay, and the destination, respectively. In the first time slot, node S transmits the data to node D . Node R can also receive this data due to the broadcast nature of the wireless channel. The received data signal at node D and R in the first time slot can be expressed as

$$y_{D,1} = \sqrt{P_S d_{S,D}^{-\alpha}} h_{S,D} x_S + n_{S,D} \quad (3.3)$$

and

$$y_R = \sqrt{P_S d_{S,R}^{-\alpha}} h_{S,R} x_S + n_{S,R}, \quad (3.4)$$

respectively, where P_S and x_S represent the transmission power and the transmitted data signal of node S . If node D can not decode the data successfully, it will ask node R to send the data overheard from node S again. Otherwise, the transmission procedure finishes. In the second time slot, node R will send the data overheard data from node S to node D only if the decoding of the overheard data from node S is successful at node R . The received data signal at node D in the second time slot can be written as

$$y_{D,2} = \sqrt{P_R d_{R,D}^{-\alpha}} h_{R,D} x_R + n_{R,D}, \quad (3.5)$$

where P_R and x_R are the transmission power and the transmitted data signal of node R .

By using the scheme in [40], the outage probability of the decode-and-forward incremental relaying protocol can be calculated as

$$p^O = \Pr(\text{outage}|SNR_{D,1} < \gamma) \times \Pr(SNR_{D,1} < \gamma), \quad (3.6)$$

where $SNR_{D,1}$ represents the SNR observed at node D after node D receives the data transmitted from node S in the first time slot. The conditional failure probability in the right hand side of (3.6) can be calculated as

$$\begin{aligned} \Pr(\text{outage}|SNR_{D,1} < \gamma) &= \Pr(SNR_R < \gamma) \\ &+ \Pr(SNR_R \geq \gamma) \\ &\times \Pr(SNR_{D,2} < \gamma|SNR_{D,1} < \gamma), \end{aligned} \quad (3.7)$$

where SNR_R is the SNR observed at node R after the data transmitted from node S is received at node R in the first time slot, and $SNR_{D,2}$ denotes the SNR observed at node D after the data transmitted from node R is received at node D in the second time slot. Because of the independence between the event $SNR_{D,2} < \gamma$ and the event $SNR_{D,1} < \gamma$, (3.7) can be calculated as

$$\begin{aligned} \Pr(\text{outage}|SNR_{D,1} < \gamma) &= \Pr(SNR_R < \gamma) \\ &+ \Pr(SNR_R \geq \gamma) \times \Pr(SNR_{D,2} < \gamma). \end{aligned} \quad (3.8)$$

By substituting (3.8) into (3.6) and replacing $\Pr(SNR_R \geq \gamma)$ with $1 - \Pr(SNR_R < \gamma)$, we can obtain

$$\begin{aligned} p^O &= \Pr(SNR_R < \gamma) \times \Pr(SNR_{D,1} < \gamma) \\ &+ \Pr(SNR_{D,2} < \gamma) \times \Pr(SNR_{D,1} < \gamma) \\ &- \Pr(SNR_R < \gamma) \times \Pr(SNR_{D,2} < \gamma) \\ &\times \Pr(SNR_{D,1} < \gamma). \end{aligned} \quad (3.9)$$

From (3.1), we can get

$$\Pr(SNR_R < \gamma) = 1 - \exp\left(-\frac{\gamma N_0}{P_S d_{S,R}^\alpha}\right), \quad (3.10)$$

$$\Pr(SNR_{D,1} < \gamma) = 1 - \exp\left(-\frac{\gamma N_0}{P_S d_{S,D}^{-\alpha}}\right), \quad (3.11)$$

and

$$\Pr(SNR_{D,2} < \gamma) = 1 - \exp\left(-\frac{\gamma N_0}{P_R d_{R,D}^{-\alpha}}\right). \quad (3.12)$$

By substituting (3.10), (3.11), and (3.12) into (3.9), we have

$$\begin{aligned} p^O &= 1 - \exp\left(-\frac{\gamma N_0}{P_S d_{S,D}^{-\alpha}}\right) - \exp\left(-\frac{\gamma N_0}{P_S d_{S,R}^{-\alpha}}\right) \\ &\quad \times \exp\left(-\frac{\gamma N_0}{P_R d_{R,D}^{-\alpha}}\right) + \exp\left(-\frac{\gamma N_0}{P_S d_{S,R}^{-\alpha}}\right) \\ &\quad \times \exp\left(-\frac{\gamma N_0}{P_R d_{R,D}^{-\alpha}}\right) \times \exp\left(-\frac{\gamma N_0}{P_S d_{S,D}^{-\alpha}}\right). \end{aligned} \quad (3.13)$$

3.4 Protocol Design

The protocol consists of three transmission phases: source-to-destination transmission phase, relay selection phase, and relay-to-destination transmission phase. In source-to-destination transmission phase, first, the source transmits the data to the destination. Then, if the destination fails to decode the received data, the destination will reply the negative acknowledge (NACK) packet to activate the relay selection phase that uses group-based probabilistic contention to select the best relay. In relay-to-destination transmission phase, the selected relay retransmits the data overheard from the source to the destination. An example of the proposed cooperative MAC protocol is illustrated in Fig. 3.1.

3.4.1 Source-to-Destination Transmission Phase

Before data transmissions, the exchange of the RTS and clear-to-send (CTS) is performed. After receiving the RTS packet from the source, each relay starts to avoid to access the medium for the network allocation vector (NAV) period. Besides, each relay estimates the distance between the source and itself by using the received RTS packet and saves the result. Before replying the CTS packet back to the destination, the destination estimates the distance between the source and itself

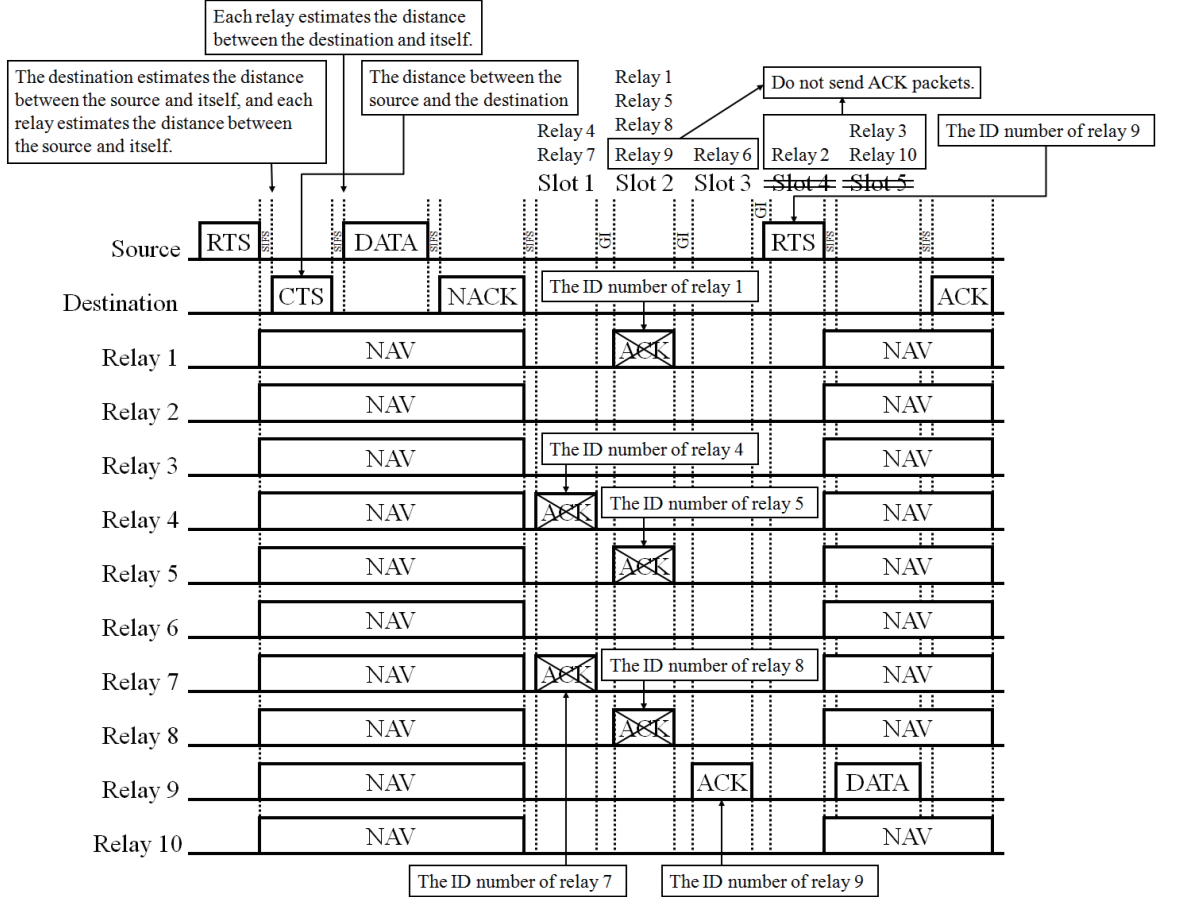

Figure 3.1: An example of the proposed cooperative MAC protocol with $K = 5$.

by using the received RTS packet and writes the result into the CTS packet. After receiving the CTS packet from the destination, each relay uses it to estimate the distance between the destination and itself and saves the result. In addition, each relay obtains the distance between the source and the destination. The distance is estimated by using the empirical path loss formula and can be calculated as

$$d = \left(\left(\frac{4\pi}{\lambda} \right)^2 \frac{P_t}{P_r} \right)^{\frac{1}{\alpha}}, \quad (3.14)$$

where P_r represents the received signal power that can be obtained by the received signal strength indicator (RSSI), P_t is the transmitted signal power, λ denotes the radio wavelength, and d denotes the distance between the transmitter and the receiver. The source transmits the data to the destination RTS after receiving the CTS packet from the destination. If the destination can decode the data successfully,

the ACK will be replied back to the source, and the communication finishes. Otherwise, as shown in Fig. 3.1, the NACK packet is replied back to the source, and each relay enters into relay selection phase after receiving the NACK packet from the destination.

3.4.2 Relay Selection Phase

According to (3.13), with the predefined knowledge of all parameters except distances, each relay uses the obtained distances between the source and itself, between the destination and itself, and between the source and the destination to calculate the outage probability of cooperative transmission. The calculated outage probability is compared to a predefined threshold η , and only those relays with outage probabilities that are smaller than η will participate the group-based probabilistic contention. The outage probability range $[0, \eta)$ is equally divided into K sections, and the range of the k th section can be given by $[(k-1)\eta/K, k\eta/K)$. Initially, the number of times that the group-based probabilistic contention will be performed is set to K . At the k th time slot, where $k = 1, \dots, K$, each relay checks if its calculated outage probability is in the range $[(k-1)\eta/K, k\eta/K)$. If a relay has an outage probability that does not belong to that range, it does not do any actions. Otherwise, it generates a uniform random variable, and sends an ACK packet containing its identification (ID) number back to the source if the generated uniform random variable is smaller than or equal to its associated probability. By doing so, the risk of high collision probability in a time slot in the conventional scheme is released due to group-based contention. Besides, the contention of the relays belonging to a group with a lower outage probability range occurs earlier. The probability of sending an ACK packet of a relay is defined such that a relay with a lower outage probability is assigned with a higher sending probability. Let $R^{(k)}$ denote the set of relays that will send ACK packets in the k th time slot, where $k = 1, \dots, K$. At the k th time slot, the probability of sending an ACK packet of

relay i can be calculated as

$$p_i^{(k)} = \begin{cases} 1 - \frac{p_i^O}{\frac{\eta}{K}k}, & \forall i \in R^{(k)}, \\ 0, & \forall i \notin R^{(k)}. \end{cases} \quad (3.15)$$

In (3.15), the purpose of the term $(p_i^O K) / (\eta k)$ is to transfer an outage probability in the range $[(k-1)\eta/K, k\eta/K)$ to a probability in the range $[0, 1)$, and the calculation $1 - (p_i^O K) / (\eta k)$ achieves that a relay with a lower outage probability is assigned with a higher probability of sending an ACK packet.

If a relay does not send the ACK packet for contention in the current time slot, it is allowed to contend one more time because the outage probability of it is lower than those of the relay candidates that will contend in the next time slot. According to (3.15), the probability of sending an ACK packet of a relay that does not send an ACK packet in the current time slot will be higher than those of the relay candidates that will contend in the next time slot.

After the contention in one time slot is finished, if only one relay sends an ACK packet to the source, that relay wins the contention and is selected. Then, the source writes the ID number of the selected relay into a RTS packet and broadcasts it to all relays. This RTS packet is used to not only inform the selection result but also to terminate the contention procedure. Between any two contention time slots, a guard interval (GI) is inserted. The length of this GI equals to the sum of two times of the maximum delay of the network and the processing time before a RTS packet containing the ID number of the selected relay is broadcasted. If the relays that will contend in the next slot does not receive any RTS packets after a GI period is passed, those relays contend again in the next slot. After the contention procedure, if the source does not obtain any ID number of relay candidates, the source retransmits the data to the destination.

In the example shown in Fig. 3.1, the outage probability range $[0, \eta)$ is divided into five sections, and the relays are divided into five groups and contend in their corresponding time slots. The collision of ACK packets occurs in time slot 1 because both relay 4 and 7 send ACK packets containing their ID numbers to contend. After a GI period is passed, because relay 1, 5, 8, and 9 do not receive any RTS packet

from the source, they contend in time slot 2. Relay 1, 5, and 8 send ACK packets containing their ID numbers to contend, and thus, the collision of ACK packets also occurs in time slot 2. Due to not sending an ACK packet for contention in time slot 2 and not receiving any RTS packet from the source after a GI period is passed, relay 9 sends an ACK packet containing its ID number to contend in time slot 3. The source broadcasts a RTS packet containing the ID number of relay 9 to inform the selection result to relay 2, 3, 9, and 10. By receiving this RTS packet, relay 2, 3, and 10 stop to contend.

3.4.3 Relay-to-Destination Transmission Phase

After receiving the RTS packet containing the ID number of the selected relay, all relays except the selected relay start to avoid to access the medium for the NAV period, and the data overheard from the source is sent to the destination by the selected relay. The destination sends an ACK packet back to the source if it can decode the data successfully.

3.5 Performance Evaluations

We investigate the performance of the conventional and proposed schemes in terms of the outage probability, the length of the contention period, and the number of ACK packets used for distributed relay selection. Table 3.1 lists the simulation parameters. According to [44], the probability of sending ACK packets in the conventional scheme is set to be 0.3. The relay candidates are randomly distributed in the area covered by the transmission ranges of the source and destination. The simulation results are averaged over 10000 network scenarios. We assume that the control packets are transmitted by using a low data rate such that they will not suffer from errors.

Threshold η relates to the number of relay candidates that participate in the relay contention. When the threshold is large, the number of relay candidates that participate in the relay contention is large. As a result, it is difficult to select

Table 3.1: Simulation Parameters.

parameter	value
SNR threshold γ	3
SNR P_S/N_0 and P_R/N_0	10^8
number of contention slots K	5
maximum transmission distance d_{max}	100m
simulation area	200m \times 200m
threshold η	0.2
spectral efficiency of the direct transmission R	2 b/s/Hz
path loss exponent α	4

the relay due to the high collision probability caused by the large number of relay candidates participating in the relay contention. Contrarily, when the threshold is small, the number of relay candidates that participate in the relay contention is small. Therefore, the contention slot will be wasted because no relay candidate will send the control packet to contend. The number of groups relates to the delay caused by the relay contention and the probability that the relay can be selected. The number of groups equals to the number of contention slots K . When the number of groups is large, the probability that the relay can be selected is high because the number of contention chances is large, and less relay candidates contend in the same contention slot. However, the system will suffer from a long delay caused by the relay contention. Contrarily, when the number of groups is small, the probability that the relay can be selected is low because the number of contention chances is small, and more relay candidates contend in the same contention slot. However, the delay caused by the relay contention is short. Therefore, there is a tradeoff between the delay caused by the relay contention and the probability that the relay can be selected when the number of groups is defined. In addition, the number of

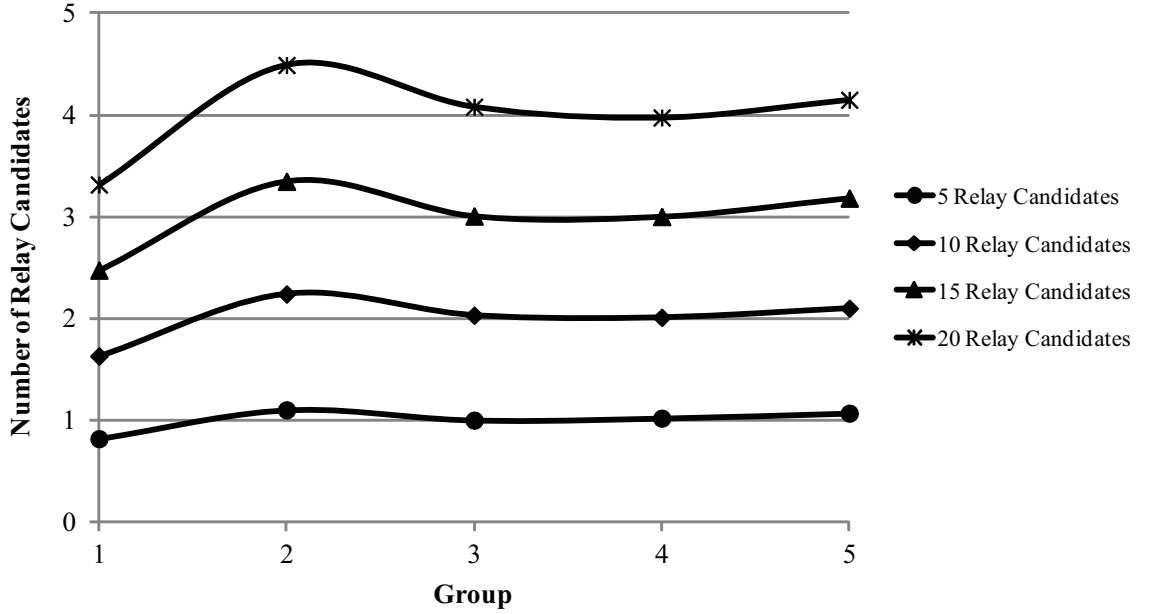

Figure 3.2: Number of relay candidates versus the group of the proposed scheme.

groups also relates to the usage efficiency of the contention slot. When the number of groups is large, the range of each group will be small. Thus, no relay candidate will belong to a contention slot and send control packets to contend. This causes the waste of the contention slot. Figure 3.2 shows the number of relay candidates versus the group of the proposed scheme. From Fig. 3.2, we can observe that by setting $K = 5$ and $\eta = 0.2$, each group has approximately the same number of relay candidates, and there is no blank group that has no relay candidate.

Figure 3.3 shows the outage probability versus the number of relay candidates of the conventional and proposed schemes. From Fig. 3.3, we can observe that the proposed scheme decreases the outage probability compared to the conventional one. This is because in the conventional scheme, after the contention finishes, the best relay is randomly selected from the relays that survive by using the same probability of sending the ACK packet for contention. As a result, the relay with the lowest outage probability may not be selected from the survived relays. However, in our proposed scheme, the relay with a lower outage probability uses a higher probability to send the ACK packet to contend earlier. Besides, the relay that does not send

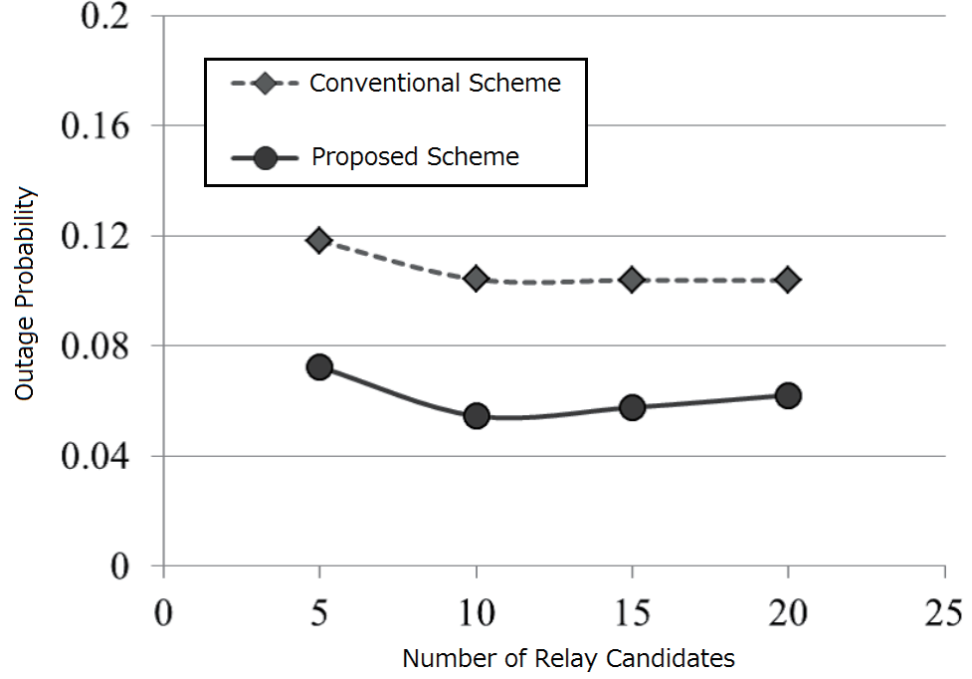

Figure 3.3: Outage probability versus the number of relay candidates.

the ACK packet in the current time slot can have one more time to contend, and its probability of sending the ACK packet is higher than those of the relay candidates that will contend in the next time slot. Therefore, a relay with a lower outage probability will be selected. Figure 3.3 also shows that when the number of relay candidates increases from 5 to 10 and from 10 to 20, the outage probability of the proposed scheme decreases and increases, respectively. The reason is described as follows. When the number of relay candidates increases, relays that participate in the contention will have lower outage probabilities due to the space diversity. In addition, the probability of the collision of ACK packets that are sent from relays with lower outage probabilities increases. Therefore, a relay with a higher outage probability may be selected.

Figure 3.4 shows the number of time slots in the contention period versus the number of relay candidates of the conventional and proposed schemes. It is shown that the proposed scheme spends less time to finish the contention period compared to the conventional scheme. The reason is that in the conventional scheme, the best

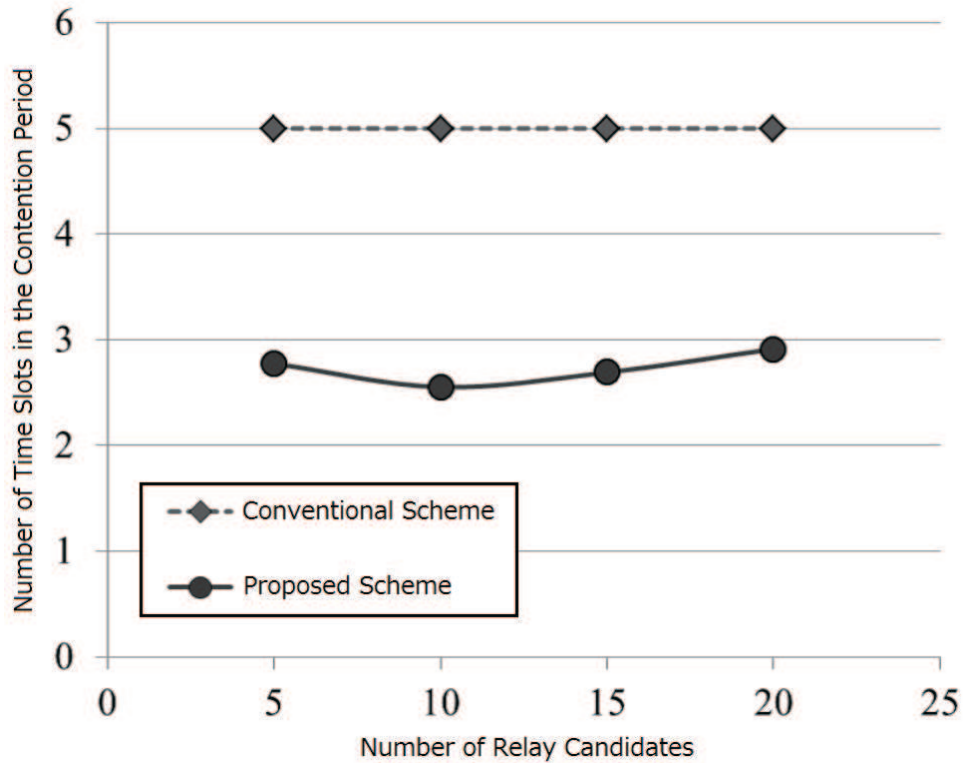

Figure 3.4: Number of time slots in the contention period versus the number of relay candidates.

relay is selected after the contention finishes. Thus, a fixed number of time slots is necessary until the contention finishes. However, in the proposed scheme, when only one relay sends the ACK packet in a time slot, the contention period is terminated. Therefore, the contention period can finish earlier.

Figure 3.5 shows the number of ACK packets used for contention versus the number of relay candidates of the conventional and proposed schemes. From Fig. 3.5, we can observe that when the number of relay candidates increases, the number of ACK packets increases. This phenomenon is caused by that more relays will have outage probabilities that are lower than η and participate in the contention when the number relay candidates increases. Figure 3.5 also shows that the proposed scheme uses less ACK packets to contend compared to the conventional one, and when the number of relay candidates increases, the number of ACK packets reduced by the proposed one increases. The first phenomenon is explained as follows. Due to

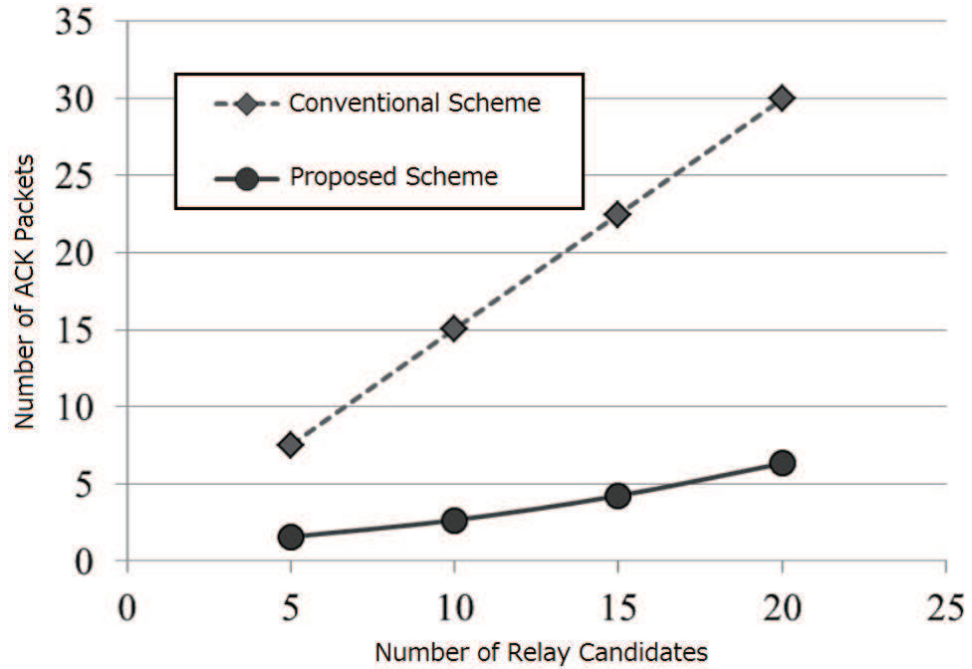

Figure 3.5: Number of ACK packets versus the number of relay candidates.

group-based relay contention and the avoidance of the unnecessary relay contention, compared to the conventional scheme, in the proposed one, less contention time slots are used, and less relays contend in each contention time slot. In addition, if once the relay sends the ACK packet, it can not participate the contention in the later time slot. Therefore, the number of ACK packets can be reduced. We explain the second phenomenon as follows. We know that when the number of relay candidates increases, more relays will contend. In all contention time slots of the conventional scheme, the numbers of relays that send ACK packets increase. However, in the proposed scheme, the numbers of relays that send ACK packets increase in fewer contention time slots compared to the conventional one.

3.6 Conclusion

By exploiting group-based probabilistic relay contention and unnecessary ACK packet avoidance and designing the contention probability based on the outage probability, we have proposed a cooperative MAC protocol that uses less number of ACK

packets to earlier select the best relay with a lower outage probability. In addition, due to the re-participation of the relay that does not send the ACK packet, the outage probability is further improved, and the time slot associated with no relay candidates is efficiently exploited. Simulation results validates the effectiveness of the proposed cooperative MAC protocol.

Chapter 4

Distributed Ad Hoc Cooperative Routing in Cluster-Based Multihop Networks

4.1 Introduction

In Chapters 2 and 3, the relay is selected to assist the one hop direct transmission. However, when the source locates far away from the destination, multihop transmissions are necessary. As a result, in this chapter, we focus on the case that cooperative transmissions are performed in multihop networks. In each hop, both the relay and receiver are selected.

In cluster-based multihop networks, ad hoc routing (AHR) that performs in a hop-by-hop fashion is proposed to reduce the implementation complexity of the optimal routing. However, the complexity reduction causes an increase of the required transmission power. In addition, when AHR is implemented by the conventional distributed relay selection, another increase of the required transmission power is caused by the receiver selection error. Thus, ad hoc cooperative routing (AHCR) is proposed to combine the cooperative transmission with AHR to reduce the difference between the required transmission power of AHR and that of optimal routing. In AHCR, the nodes with the minimum and the second minimum required sender transmission power are selected as the receiver and the relay, respectively, to perform the cooperative transmission. We also propose distributed ad hoc cooperative routing (DAHCR) scheme 1 to reduce the difference between the required transmission power of distributed ad hoc routing (DAHR) and that of AHR. In DAHCR scheme 1, each node uses the same probability to contend for being selected as the receiver and the relay, and two nodes are randomly selected to perform the cooperative transmission. To solve the problem of DAHCR scheme 1, DAHCR scheme 2 is proposed. In DAHCR scheme 2, a higher contention probability is assigned to a node with lower

required sender transmission power. Besides, the nodes with the minimum and the second minimum required sender transmission power are selected as the receiver and the relay, respectively, to perform the cooperative transmission. Simulation results show that the proposed routing schemes reduce the required transmission power. On the other hand, DAHCR scheme 1 increases the complexity by 43% compared to DAHR. Besides, DAHCR scheme 2 increases the complexity by 1.97% compared to DAHCR scheme 1.

The rest of this chapter is organized as follows. We present AHR and the conventional distributed relay selection in Section 4.2 and Section 4.3, respectively. Section 4.4 describes the system model including the transmission model, the direct and the cooperative transmissions, and the link analysis. Section 4.5 describes DAHR. Section 4.6 presents AHCR, DAHCR scheme 1 and its problem, and DAHCR scheme 2. The performance evaluation is presented in Section 4.7. Section 4.8 gives the conclusion.

4.2 System Model

4.2.1 Transmission Model

Each node is assumed to have a single antenna due to size and power constraints. The effects of the long term free space path loss and the short term Rayleigh fading are jointly considered in the channel of each link. The free space path loss is expressed as

$$G = \left(\frac{4\pi}{\lambda}\right)^2 \left(\frac{1}{d}\right)^\alpha, \quad (4.1)$$

where G denotes the channel gain, λ is the radio wavelength, d represents the transmission distance, and α denotes the path loss exponent. Over one frame interval, we assume that the channel coefficients are static and change independently from one frame interval to another.

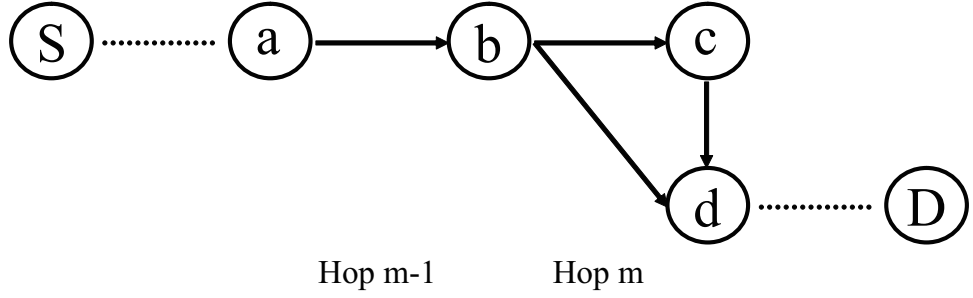

Figure 4.1: Direct and cooperative transmissions in hop $m - 1$ and m , respectively.

4.2.2 Direct and Cooperative Transmissions

For the direct transmission illustrated in hop $m - 1$ in Fig. 4.1, nodes a and b represent the sender and the receiver, respectively. The received signals at the receiver can be presented as

$$y_b = \sqrt{P_a G_{ab}} h_{ab} x + n_{ab}, \quad (4.2)$$

where P_a denotes the sender transmission power, G_{ab} represents the channel gain between the sender and the receiver, h_{ab} represents the Rayleigh fading coefficient, x is the data signal, and n_{ab} is an additive noise observed at receiver b when node a is the sender and modeled as a zero mean complex Gaussian random variable with variance N_0 .

For the cooperative transmission depicted in hop m in Fig. 4.1, nodes b , c , and d represent the sender, the relay, and the receiver, respectively. We adopt the decode-and-forward incremental relaying protocol proposed in [30]. The whole transmission period is divided into two time slots. In the first time slot, the sender sends its data signal to the receiver. Due to the broadcast nature of wireless channel, the transmitted data signal can also be heard by the relay. The received signals at the relay and the receiver can be presented as

$$y_c = \sqrt{P_b G_{bc}} h_{bc} x + n_{bc} \quad (4.3)$$

and

$$y_{d,1} = \sqrt{P_b G_{bd}} h_{bd} x + n_{bd}, \quad (4.4)$$

respectively, where n_{bc} and n_{bd} are additive noises observed at receiver c and receiver d when node b is the sender, respectively and modeled as zero mean complex Gaussian random variables with variance N_0 . After the first time slot, the receiver decodes its received signal. We assume that the decoding is correct if the received Signal-to-Noise Ratio (SNR) is higher than some defined threshold. If the decoding is successful, the receiver replies the acknowledgement (ACK) packet back to the sender. Otherwise, the negative acknowledgement (NACK) packet is sent back, and the relay transmits the data signal to the receiver in the second time slot if the decoding at the relay is correct. The received signal at the receiver can be formulated as

$$y_{d,2} = \sqrt{P_c G_{cd}} h_{cd} x + n_{cd}, \quad (4.5)$$

where n_{cd} is an additive noise observed at receiver d when node c is the sender and modeled as a zero mean complex Gaussian random variable with variance N_0 .

4.2.3 Link Analysis

Our objective is to find the power minimized route which achieves the required throughput. When applying the direct or the cooperative transmission, the minimum required transmission power for achieving the end-to-end required throughput is derived by using the scheme in [80]. The mutual information of the direct transmission can be described as

$$I_{ab} = \log\left(1 + \frac{P_a G_{ab} |h_{ab}|^2}{N_0}\right), \quad (4.6)$$

where N_0 represents the noise variance. The outage probability of the direct transmission is given by

$$p_{ab}^O = Pr(I_{ab} \leq R_{ab}), \quad (4.7)$$

where R_{ab} denotes the required transmission rate. By substituting (4.6) into (4.7), the outage probability can be expressed as

$$p_{ab}^O = Pr(|h_{ab}|^2 \leq \frac{(2^{R_{ab}} - 1)N_0}{P_a G_{ab}}). \quad (4.8)$$

Since the h represents the Rayleigh fading coefficient, the channel gain $|h_{ab}|^2$ is an exponential random variable, and its probability density function equals to $\exp(-|h_{ab}|^2)$ for $|h_{ab}|^2 \geq 0$. Thus, the outage probability can be written as

$$p_{ab}^O = 1 - \exp\left(-\frac{(2^{R_{ab}} - 1)N_0}{P_a G_{ab}}\right). \quad (4.9)$$

By substituting the probability of success p_{ab}^S which equals to $1 - p_{ab}^O$ into (4.9) and performing some calculations, the minimum required transmission power is presented as

$$P_a = -\frac{(2^{R_{ab}} - 1)N_0}{\log(p_{ab}^S)G_{ab}}. \quad (4.10)$$

The total outage probability of the cooperative transmission can be formulated as

$$\begin{aligned} p_{bcd}^O &= Pr(I_{bd} \leq R^C) \cdot Pr(I_{bc} \leq R^C) \\ &+ Pr(I_{bd} \leq R^C) \cdot Pr(I_{cd} \leq R^C) \\ &- Pr(I_{bd} \leq R^C) \cdot Pr(I_{bc} \leq R^C) \\ &\cdot Pr(I_{cd} \leq R^C), \end{aligned} \quad (4.11)$$

where R^C is the transmission rate in each time slot. For simplicity, we assume that the transmitted power of the sender equals to that of the relay. Thus, we can calculate the probability of success of the cooperative transmission as follows;

$$\begin{aligned} p_{bcd}^S &= \exp(-gG_{bd}^{-1}) + \exp(-g(G_{bc}^{-1} + G_{cd}^{-1})) \\ &- \exp(-g(G_{bc}^{-1} + G_{cd}^{-1} + G_{bd}^{-1})), \end{aligned} \quad (4.12)$$

where

$$g = \frac{(2^{R^C} - 1)N_0}{P^C}. \quad (4.13)$$

The probability that only the sender transmits is given by

$$p_b = 1 - \exp(-gG_{bc}^{-1}) + \exp(-g(G_{bc}^{-1} + G_{bd}^{-1})). \quad (4.14)$$

Besides, we can write the average transmission rate of the cooperative transmission as

$$R = R^C \cdot p_b + \frac{R^C}{2} \cdot (1 - p_b) = \frac{R^C}{2}(1 + p_b). \quad (4.15)$$

By using $\exp(-x) \approx 1 - x + x^2/2$ to approximate the exponential function in (4.12), g can be approximated by

$$g \approx \sqrt{\frac{1 - p_{bcd}^S}{G_{bd}^{-1}(G_{bc}^{-1} + G_{cd}^{-1})}}. \quad (4.16)$$

By using (4.13) and (4.16), the required transmission power per link is expressed as

$$P^C \approx (2^{R^C} - 1)N_0 \sqrt{\frac{G_{bd}^{-1}(G_{bc}^{-1} + G_{cd}^{-1})}{1 - p_{bcd}^S}}. \quad (4.17)$$

Finally, we can describe the total required transmission power of the cooperative transmission as

$$P = P^C \cdot p_b + 2P^C \cdot (1 - p_b) = P^C(2 - p_b). \quad (4.18)$$

4.3 Distributed Ad Hoc Routing (DAHR)

When implementing AHR proposed in [22], the distributed relay selection described in the previous section is modified and adopted in hop m , where $m = 1, \dots, M - 2$. An example of the transmission procedure for DAHR is shown in Fig. 4.2. When the sender in cluster $m - 1$ has data to transmit, it broadcasts the request-to-send (RTS) packet to all nodes in cluster m . After receiving the RTS packet, each node exploits it to estimate the channel gain between the sender and itself and calculates the required sender transmission power according to (4.10). If the required sender transmission power is lower than the threshold η^P , the node starts to contend by replying the ACK packet containing its identification (ID) address to the sender with a probability p_1^{pro} continuously for k times. Otherwise, different from the conventional distributed relay selection scheme, the node contends by a low probability p_{low} near zero to prevent the occurrence of the situation that no ACK packet is sent during the contention period because the required sender transmission power of each node is higher than the threshold η^P . Between any two

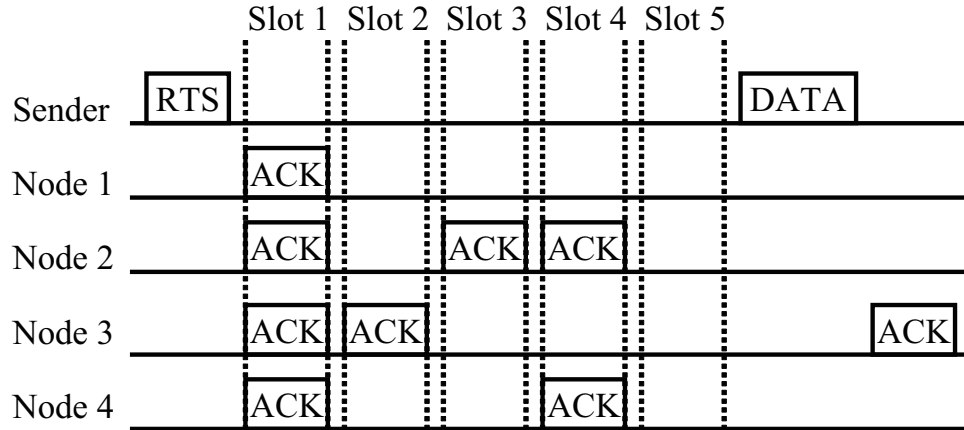

Figure 4.2: An example of the transmission procedure for the DAHR.

consecutive transmissions of the ACK packets, a guard interval with the length of the propagation delay of the network is inserted to prevent collisions. During each slot, if only one ACK packet is received, the sender in will memorize the ID address contained in it. In other cases, the multiple ACK packets collide with each other or all the nodes do not send the ACK packet. If the sender does not memorize any ID address during the contention period, the sender will transmit the RTS packet again to trigger another contention period. If more than one node's ID address exist, the sender randomly selects one node as the receiver. Then, the sender broadcasts the data packet containing the ID address of the selected node to all nodes. The selected node replies the ACK packet to the sender, after receiving the data packet. Note that when the required sender transmission power of the node is higher than the threshold η^P , if we do not let the node contend by the low probability p_{low} , the contention period will be triggered continuously.

4.4 Proposed Routing Schemes

4.4.1 Ad Hoc Cooperative Routing (AHCR)

We propose to integrate the cooperative transmission with AHR to reduce the difference between the required transmission power of AHR and that of optimal

routing. Besides the receiver that needs the minimum required sender transmission power, the node with the second minimum required sender transmission power is selected as the relay. For hop $m = 1, \dots, M - 2$, among the links from the sender i^* in cluster $m - 1$ to each node in cluster m , the link with the minimum $P_{i^*,j,m}$ is selected. That is $j^* = \arg \min_{j=1,\dots,L} P_{i^*,j,m}$, where j^* is the selected receiver in cluster m . Besides, the link with the second minimum $P_{i^*,j,m}$ is selected. That is $j^{**} = \arg \min_{j=\{1,\dots,L\}-\{j^*\}} P_{i^*,j,m}$, where j^{**} is the selected relay in cluster m . After the receiver and the relay are selected, the cooperative transmission is performed. There are two times slots in the cooperative transmission. In the first time slot, the sender sends the data packet to the receiver. Due to the broadcast nature of wireless channel, the relay can also receive this data packet. At the receiver, if the decoding of the overheard data packet is successful, the ACK packet is replied back to the sender and the relay, and the transmission procedure finishes. Otherwise, the receiver sends the NACK packet to the relay, and the relay sends the data packet to the receiver in the second time slot if the relay decodes the overheard data packet successfully in the first time slot. To select the node in cluster $M - 1$, we first calculate $P_{i^*,j,M-1} + P_{j,D,M}$ that represents the power of the path passing through node j in cluster $M - 1$ between the sender i^* in cluster $M - 2$ and the destination, where $j = 1, \dots, L$. The path with the minimum $P_{i^*,j,M-1} + P_{j,D,M}$ is selected. That is, $j^* = \arg \min_{j=1,\dots,L} P_{i^*,j,M-1} + P_{j,D,M}$, where j^* is the selected passing node in cluster $M - 1$. An example of AHCR with $M = 4$ and $L = 4$ is illustrated in Fig. 4.3.

4.4.2 Distributed Ad Hoc Cooperative Routing

(DAHCR)

4.4.2.1 Scheme 1

We propose to integrate the cooperative transmission with DAHR to reduce the difference between the required transmission power of DAHR and that of AHR. An example of the transmission procedure for DAHCR scheme 1 is illustrated in Fig.

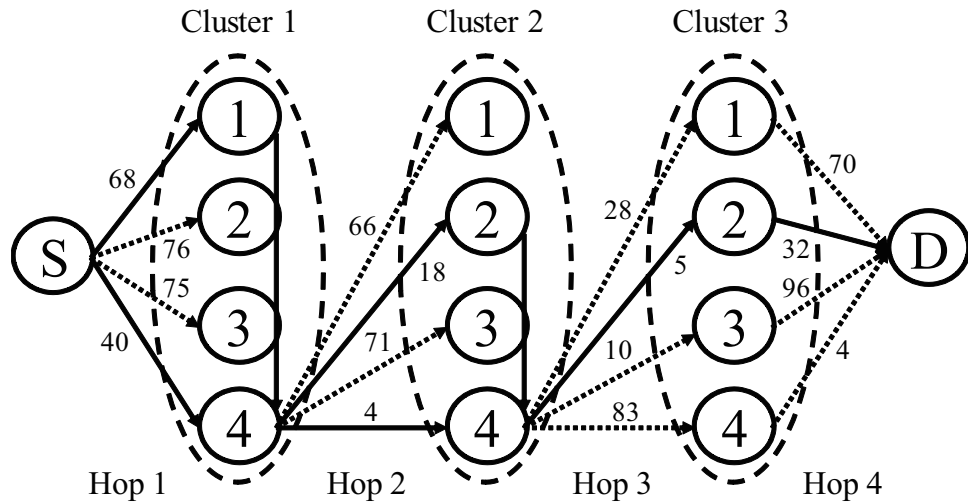

Figure 4.3: An example of AHCR with $M = 4$ and $L = 4$.

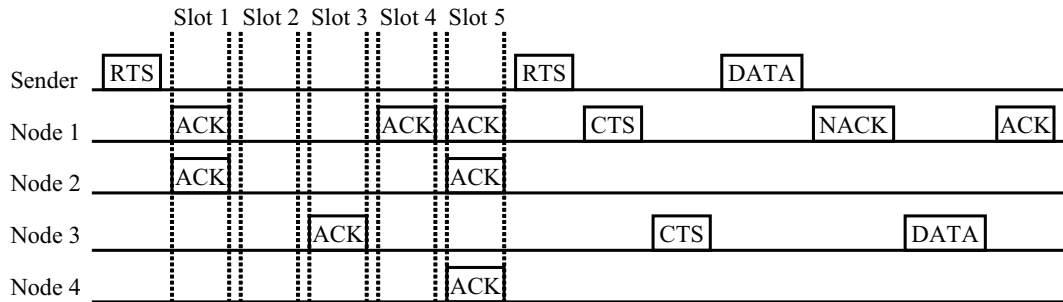

Figure 4.4: An example of the transmission procedure for DAHCR scheme 1 and DAHCR scheme 2.

4.4. The contention procedure is same as that of DAHR. Different from DAHR, after the contention procedure, the sender randomly selects one node as the receiver and another as the relay to implement the cooperative transmission. If only one node exists, it is still selected, and the RTS packet containing its ID address is sent to all nodes to inform the selection result and also request a new contention period. In the new contention period, that selected node will withdraw its contention.

When the receiver and the relay are selected, the sender broadcasts the RTS packet containing these two nodes' ID addresses to all nodes to inform the selection result. The sender also starts to count the time after broadcasting the RTS packet.

In the example shown in Fig. 4.4, nodes 1 and 3 are selected as the receiver and the relay, respectively. According to (4.17), the sender and the relay need to obtain G_{bd} , G_{bc} , and G_{cd} to calculate the required transmission power for performing the cooperative transmission. The sender uses the ACK packets received during the contention period to estimate G_{bd} and G_{bc} and memorizes them. The relay uses the RTS packet transmitted by the sender before the contention period to estimate G_{bc} and memorize it. In the similar way, the receiver obtains G_{bd} . To let the sender and the relay know G_{cd} and the relay know G_{bd} , the receiver sends the Clear-to-Send (CTS) packet containing G_{bd} to the relay. The relay exploits it to estimate G_{cd} and sends this information to the sender by another CTS packet. However, the relay is sometimes out of the transmission range of the receiver and can not receive the CTS packet containing the channel gain G_{bd} . In this case, the relay will also not reply the CTS packet containing the channel gain G_{cd} to the sender. Thus, if the sender does not receive the CTS packet until the time exceeds the timeout, the sender will use the required transmission power of the direct transmission obtained from (4.10) to send the data packet.

The sender uses the required transmission power obtained from (4.17) to send its data packet to the receiver. At the receiver, if the decoding of the received data packet is correct, the ACK packet is replied back to the sender. Otherwise, as shown in Fig. 4.4, the NACK packet is sent, and the relay also uses the required transmission power obtained from (4.17) to send another version of the overheard data packet to the receiver. The receiver replies the ACK packet back to the sender if the decoding of the received data packet is correct.

The main problem of the scheme 1 is that all nodes send the ACK packets for contention with the same probability p_1^{pro} , and the selected relay and receiver are decided randomly without considering the required sender transmission power. The same sending probability p_1^{pro} means that the nodes with higher and lower required sender transmission power have the same chance to contend in the node selection. However, the nodes with lower required sender transmission power should be given more opportunity to be selected as the receiver and the relay because they can

improve the system performance.

4.4.2.2 Scheme 2

We propose to define the contention probability p_2^{pro} based on the required sender transmission power. The node with less required sender transmission power is given a higher contention probability p_2^{pro} . In addition, each node contends by sending the modified ACK packet that the receiver address (RA) field is fulfilled with its ID address and required sender transmission power. By this way, the sender is able to select the two nodes with the minimum and the second minimum required sender transmission power for the cooperative transmission. The node with the minimum required sender transmission power is for the receiver and the other is for the relay.

The transmission procedure is same as that shown in Fig. 4.4. When the sender in cluster $m - 1$ has data to transmit, it broadcasts the RTS packet to each node in cluster m . After receiving the RTS packet, each node exploits it to estimate the channel gain between the sender and itself and calculates the required sender transmission power according to (4.10). Different from the scheme 1, the contention probability p_2^{pro} of each node is calculated as

$$p_2^{pro} = 1 - \frac{P_s}{P_{max}}, \quad (4.19)$$

where P_s and P_{max} denote the required sender transmission power and the maximum required sender transmission power, respectively. The maximum required sender transmission power is defined as the transmission power required for transmitting information over the maximum transmission distance to satisfy the required transmission rate and probability of success. The contention probability p_2^{pro} is then compared with the threshold η^p . Based on the result, another contention probability p_3^{pro} is defined for each node. If the contention probability p_2^{pro} is higher than the threshold η^p , the contention probability p_3^{pro} is calculated as

$$p_3^{pro} = p_{low} + \frac{(1 - p_{low})(p_2^{pro} - \eta_2^{pro})}{1 - \eta_2^{pro}}. \quad (4.20)$$

Otherwise, the contention probability p_3^{pro} will be set to the low probability p_{low} . This equation re-distributes the contention probabilities p_2^{pro} 's which locate between the threshold η^p and 1 to the range between p_{low} and 1. This approach increases the difference between any two p_2^{pro} 's which are larger than the threshold η^p and let the node with the highest p_2^{pro} have more opportunity to be selected.

After the calculation of the contention probability p_3^{pro} , each node uses it to continuously reply the modified ACK packet containing its ID address and required sender transmission power back to the sender for k times. In order to let the sending probability of the modified ACK packet be p_3^{pro} , each node generates a uniformly distributed random variable and compares it to the contention probability p_3^{pro} . If the uniformly distributed random variable is smaller than or equal to the contention probability p_3^{pro} , the node sends the modified ACK packet back to the sender. Otherwise, the node does not perform any action. Between any two consecutive transmissions of the modified ACK packet, a guard interval with the length of the propagation delay of the network is inserted to prevent collisions. During each contention slot, if only one modified ACK packet is received, the sender will memorize the ID address and the required sender transmission power contained in it. In other cases, the multiple modified ACK packets collide with each other or all the nodes do not send the modified ACK packet. If the sender does not memorize any ID address and required sender transmission power during the contention period, the sender will transmit the RTS packet again to trigger another contention period. If only one node exists, it is still selected, and the RTS packet containing its ID address is sent to all nodes to inform the selection result and also request a new contention period. In the new contention period, that selected node will withdraw its contention. Different from the scheme 1, instead of randomly selecting one node as the receiver and another as the relay, the scheme 2 selects the two nodes with the minimum and the second minimum required sender transmission power to implement a cooperative transmission. The node with the minimum required sender transmission power is for the receiver and the other is for the relay. After the receiver and the relay are selected, the sender, the relay, and the receiver perform the

Table 4.1: Simulation Parameters.

parameter	value
contention probability p_1^{pro}	0.3
maximum transmission distance d_{max}	100m
noise power N_0	-70 dbm
path loss exponent α	3
probability p_{low}	0.1
transmission frequency	2.4 GHz
transmission rate R^C	2 b/s/Hz
probability of success p^S	0.95

same transmission procedure described in scheme 1 to implement the cooperative transmission.

The channel gain estimation method is described as follows. After each node receives the control packet such as the RTS packet, the CTS packet, the ACK packet, the NACK packet, and etc., each node will obtain the received signal power P_r by the Received Signal Strength Indicator (RSSI) and estimate the channel gain G according to $G = P_r/P_t$, where P_t is the transmitted signal power of the control packet. P_t can be calculated and obtained at each node before the system operates.

4.5 Performance Evaluation

The simulation parameters are summarized in Table 4.1. We simulate the scenario that cluster m consists of L_m relays, where $m = 1, \dots, M - 1$. The value of L_m is randomly generated using a maximum value L_{max} . The distance between node i in cluster $m - 1$ and node j in cluster m is also randomly generated, where $i = 1, \dots, L_{m-1}$, $j = 1, \dots, L_m$, and $m = 1, \dots, M - 1$. The maximum required sender

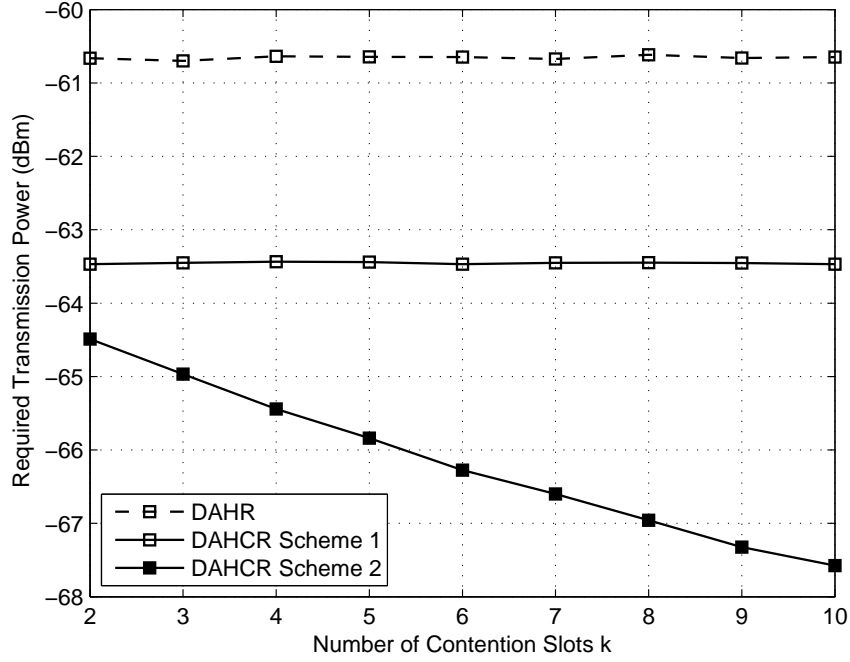

Figure 4.5: Required transmission power versus the number of contention slots k of the distributed routing schemes with $M = 10$, $L_{max} = 10$, $\eta^p = 0.75$, and $\tau = 1.9$.

transmission power is calculated as

$$P_{max} = -\frac{(2^{R^C} - 1)N_o}{\log(p^S)16\pi^2\lambda^{-2}d_{max}^{-\alpha}}. \quad (4.21)$$

The simulation results are averaged over 10000 network scenarios.

To decide the number of contention slots k , we evaluate the required transmission power and the delay caused by the contention procedure per hop at different numbers of contention slots k . Figure 4.5 and Fig. 4.6 show the required transmission power and the delay caused by the contention procedure per hop versus the number of contention slot k of the distributed routing schemes with $M = 10$, $L_{max} = 10$, $\eta^p = 0.75$, and $\tau = 1.9$, respectively, where τ represents the throughput and can be calculated according to $\tau = p^S \times R$, where p^S is the probability of success and can be calculated according to $p^S = 1 - p^O$, where p^O is the outage probability and can be calculated according to (4.9). To obtain the power threshold η^P , it is required to establish the relation between the power threshold η^P and the prob-

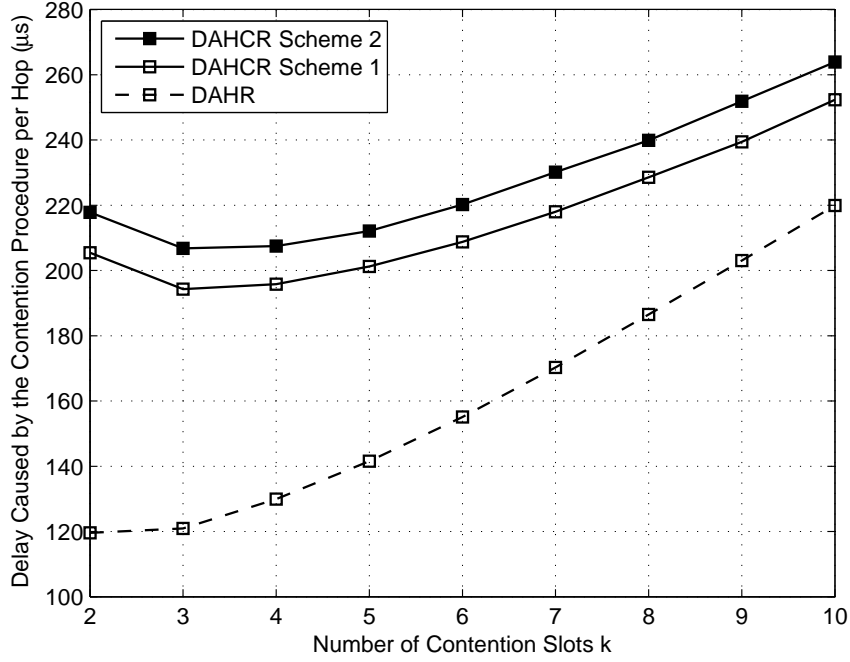

Figure 4.6: Delay caused by the contention period per hop versus the number of contention slots k of the distributed routing schemes with $M = 10$, $L_{max} = 10$, $\eta^p = 0.75$, and $\tau = 1.9$.

ability threshold η^p . The relation between the contention probability p_2^{pro} and the required sender transmission power P_s is expressed by (4.19). By substituting p_2^{pro} and P_s in (4.19) by η^p and η^P , respectively, and manipulating the equation, we can get $\eta^P = (1 - \eta^p)P_{max}$. According to the standard of IEEE 802.11a, the control packets including the RTS packet and the ACK packet are transmitted at 6 Mbps. Besides, the RTS packet size and the ACK packet size are 160 bits and 112 bits, respectively. The transmission time can be calculated by dividing the transmission size by the transmission rate. The transmission times of one RTS packet and one ACK packet require 2.67×10^{-5} s and 1.87×10^{-5} s, respectively. From Fig. 4.5, we can observe that when the number of contention slots k increases, the required transmission powers of DAHR and DAHCR scheme 1 remain almost constant, and that of DAHCR scheme 2 decreases. In DAHR, the required transmission power remains

almost constant because the receiver is randomly selected. In DAHCR scheme 1, the required transmission power remains almost constant because the receiver and the relay are both randomly selected. In DAHCR scheme 2, the nodes with the minimum and the second minimum required transmission power are selected. In addition, the occurrence probability of the event that the nodes with the minimum and the second minimum required transmission power survive increases when the number of contention slots k increases. As a result, the required transmission power of DAHCR scheme 2 decreases when the number of contention slots k increases. From Fig. 4.6, we can observe that when the number of contention slots k increases, the delay caused by the contention procedure per hop of DAHR, DAHCR scheme 1, and DAHCR scheme 2 increases except from $k = 2$ to 3 of DAHCR scheme 1 and DAHCR scheme 2. In DAHCR scheme 1 and DAHCR scheme 2, two nodes are selected. The number of contention periods at $k = 2$ is higher than that at $k = 3$. Therefore, in DAHCR scheme 1 and DAHCR scheme 2, the delay caused by the contention procedure per hop at $k = 2$ is higher than that at $k = 3$. The selection criteria of number of contention slots k is that in DAHCR scheme 2, among k having the minimum delay and those having the delays approaching the minimum, select k having the minimum required transmission power. From Fig. 8, we can observe that the delay caused by the contention procedure per hop of DAHCR scheme 2 at $k = 3$ is the minimum, and those at $k = 4$ and 5 approach that at $k = 3$. From Fig. 4.5, we can observe that among the required transmission power at $k = 5$ is the minimum among $k = 3, 4,$ and 5. Therefore, we set $k = 5$ to do other performance evaluation.

Figure 4.7 illustrates the required transmission power versus the threshold η^p of the distributed routing schemes with $M = 10$, $L_{max} = 10$, $\tau = 1.9$, and $k = 5$. Observing from the results, changing the threshold η^p has larger effect on the required transmission power of DAHCR scheme 2 than that of DAHR and DAHCR scheme 1. When the threshold η^p is increased, the required transmission power of DAHCR scheme 2 is also increased.

Figure 4.8 illustrates the number of contention periods per hop versus the

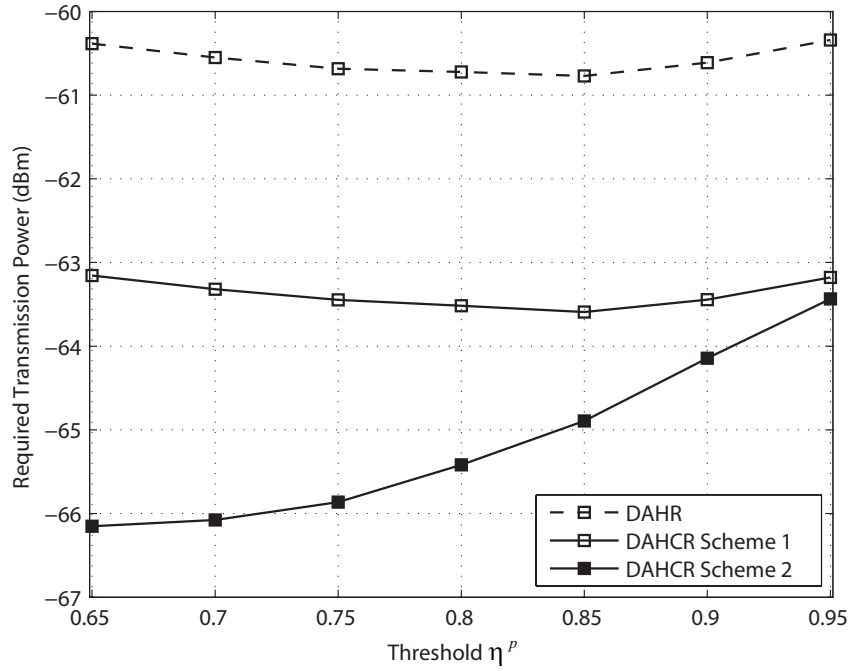

Figure 4.7: Required transmission power versus the threshold η^p of the distributed routing schemes with $M = 10$, $L_{max} = 10$, $\tau = 1.9$, and $k = 5$.

threshold η^p of the distributed routing schemes with $M = 10$, $L_{max} = 10$, $\tau = 1.9$, and $k = 5$. Same as the results shown in Fig. 4.7, the threshold η^p has larger effect on the required transmission power of DAHCR scheme 2 than that of DAHR and DAHCR scheme 1. The maximum number of contention period of DAHCR scheme 2 is decreased when the threshold η^p is increased.

Figure 4.9 shows the required transmission power versus the number of hops M of various routing schemes with $\eta^p = 0.75$, $L_{max} = 5$, $\tau = 1.9$, and $k = 5$. We can observe that the cooperative diversity can reduce the required transmission power. In the following, we describe the amounts of improvements achieved at $M = 20$. AHCR reduces the required transmission power by 33.49% compared to AHR and reduces the difference between the required transmission power of AHR and that of optimal routing by 54.96%. In addition, the cooperative diversity can achieve the power saving of 54.04% and reduce the difference between the required transmission

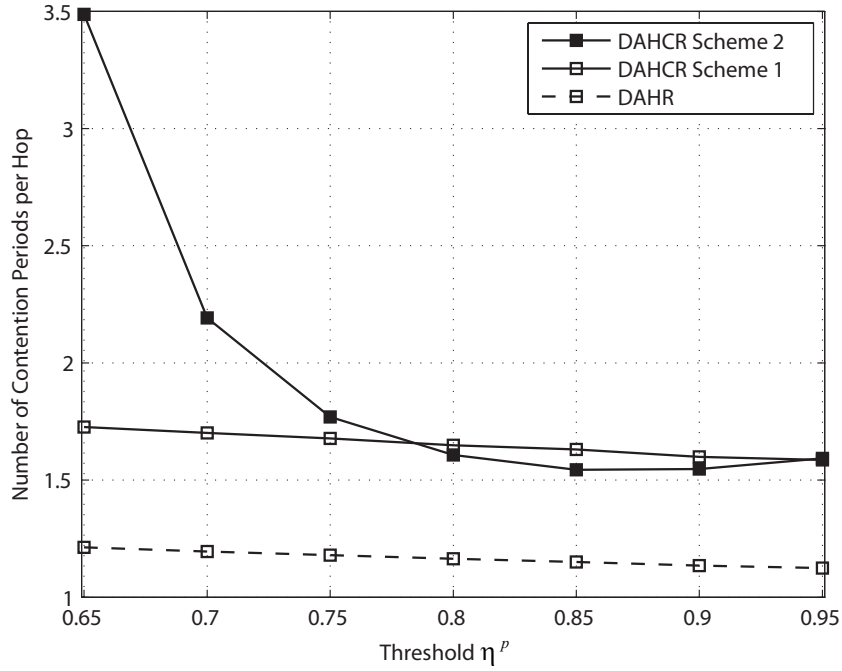

Figure 4.8: Number of contention periods per hop versus the threshold η^p of the distributed routing schemes with $M = 10$, $L_{max} = 10$, $\tau = 1.9$, and $k = 5$.

power of DAHR and that of AHR by 70.5% when it is applied with DAHR. DAHCR scheme 2 reduces the power by 40.38% compared to DAHCR scheme 1 and further reduces the difference between the required transmission power of DAHR and that of AHR by 24.21%.

Figure 4.10 illustrates the number of contention periods per hop versus the number of hops M of the distributed routing schemes with $\eta^p = 0.75$, $L_{max} = 5$, $\tau = 1.9$, and $k = 5$. At $M = 20$, DAHCR scheme 1 increases the complexity by 43% with respect to DAHR due to the selection of both the receiver and the relay. Besides, compared to DAHCR scheme 1, the complexity increasing of DAHCR scheme 2 is 1.97%. Fig. 4.10 also reveals that the increasing of the numbers of contention periods per hop of DAHCR scheme 1 and 2 starts to saturate from 10 hops.

Figure 4.11 depicts the required transmission power versus the maximum num-

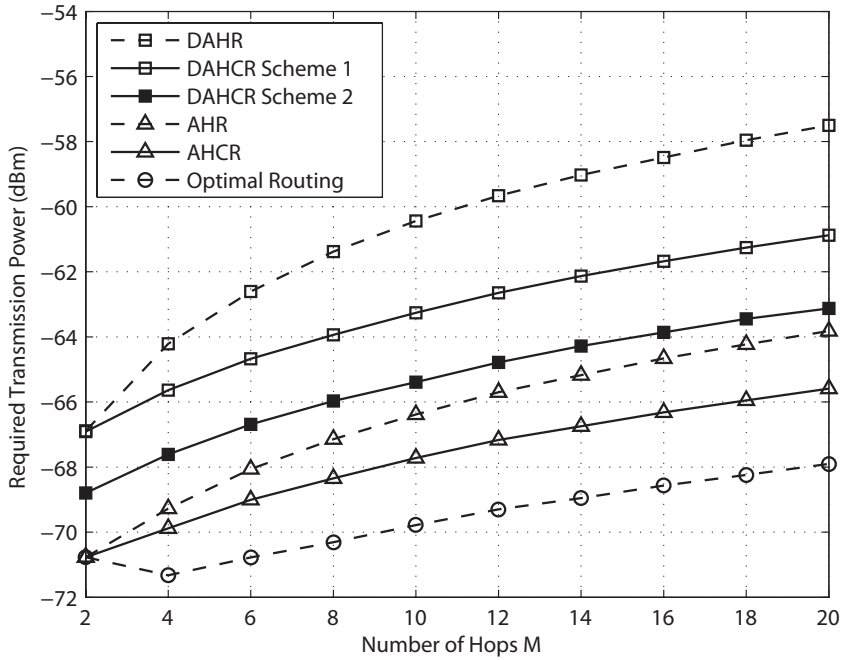

Figure 4.9: Required transmission power versus the number of hops M of various routing schemes with $\eta^p = 0.75$, $L_{max} = 5$, $\tau = 1.9$, and $k = 5$.

ber of nodes in each cluster L_{max} of various routing schemes with $\eta^p = 0.75$, $M = 10$, $\tau = 1.9$, and $k = 5$. The power saving can also be achieved by the cooperative diversity. The amounts of improvements achieved at $L_{max} = 10$ are described as follows. Compared to AHR, AHCR reduces the required transmission power by 23.77%. The cooperative diversity reduces the difference between the required transmission power of AHR and that of optimal routing by 35.62%. Besides, DAHCR scheme 1 achieves the power saving by 46.99% with respect to DAHR. The cooperative diversity reduces the difference between the required transmission power of DAHR and that of AHR by 55.33%. DAHCR scheme 2 saves the power by 42.29% with respect to DAHCR scheme 1 and further reduces the difference between the required transmission power of DAHR and that of AHR by 26.4%.

Figure 4.12 shows the number of contention periods per hop versus the maximum number of nodes in each cluster L_{max} of the distributed routing schemes with

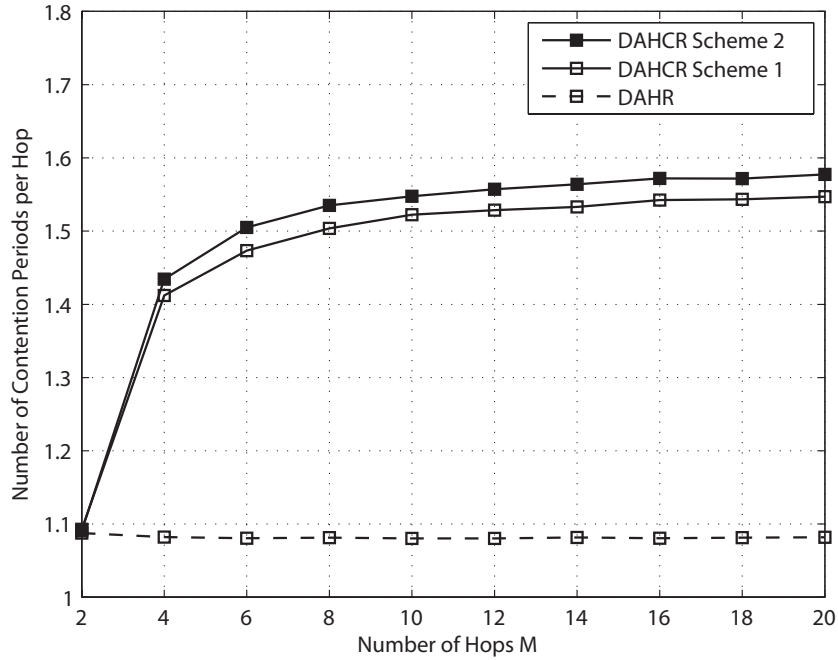

Figure 4.10: Number of contention periods per hop versus the number of hops M of the distributed routing schemes with $\eta^p = 0.75$, $L_{max} = 5$, $\tau = 1.9$, and $k = 5$.

$\eta^p = 0.75$, $M = 10$, $\tau = 1.9$, and $k = 5$. At $L_{max} = 10$, compared to DAHCR, DAHCR scheme 1 increases the complexity by 41.81% because the sender selects both the receiver and the relay. In addition, DAHCR scheme 2 increases the complexity by 6% with respect to DAHCR scheme 1.

From Fig. 4.12, when the maximum number of nodes in each cluster equals to 2, the numbers of contention periods per hop of DAHCR scheme 1 and 2 are particularly high. There are two reasons for this phenomenon. One reason is that in DAHCR scheme 1, the required sender transmission power of these two nodes is higher than the threshold γ . Thus, these two nodes contend by the low probability p_{low} . In DAHCR scheme 2, the contention probabilities p_2^{pro} 's of these two nodes are both lower than or equal to the threshold η^p . As a results, both the contention probabilities p_2^{pro} 's are reset to the low probability p_{low} . Consequently, in DAHCR scheme 1 and 2, these two nodes may almost not send the CTS packet during the

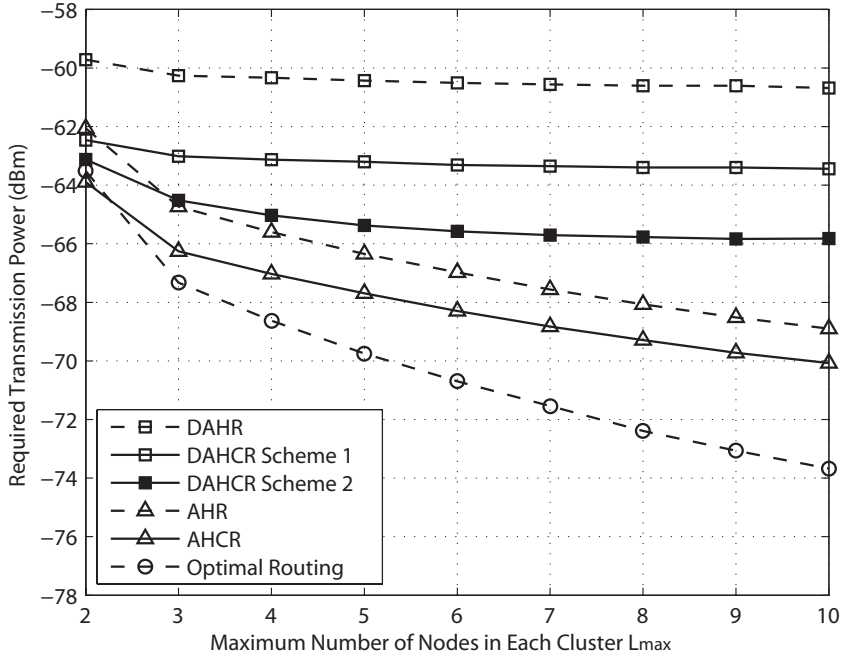

Figure 4.11: Required transmission power versus the maximum number of nodes in each cluster L_{max} of various routing schemes with $\eta^p = 0.75$, $M = 10$, $\tau = 1.9$, and $k = 5$.

whole contention period. This causes that it needs more contention periods to select the receiver and the relay. The other reason is that in DAHCR scheme 1, only one node contends by the low probability p_{low} . The other node with the contention probability p_1^{pro} will be probably first selected as the receiver. In DAHCR scheme 2, only one of the contention probabilities p_2^{pro} 's of these two nodes is reset to the low probability p_{low} . The other contention probability p_2^{pro} will be transformed to a new probability p_3^{pro} which is higher than the low probability p_{low} according to (20). If the contention probability p_3^{pro} is approximated to the low probability p_{low} , the consequence is same as that of the first reason. Otherwise, the node with the contention probability p_3^{pro} can be probably first selected as the receiver. In DAHCR scheme 1 and 2, the node that is selected as the receiver will withdraw its contention at the next contention period. However, the other node with the

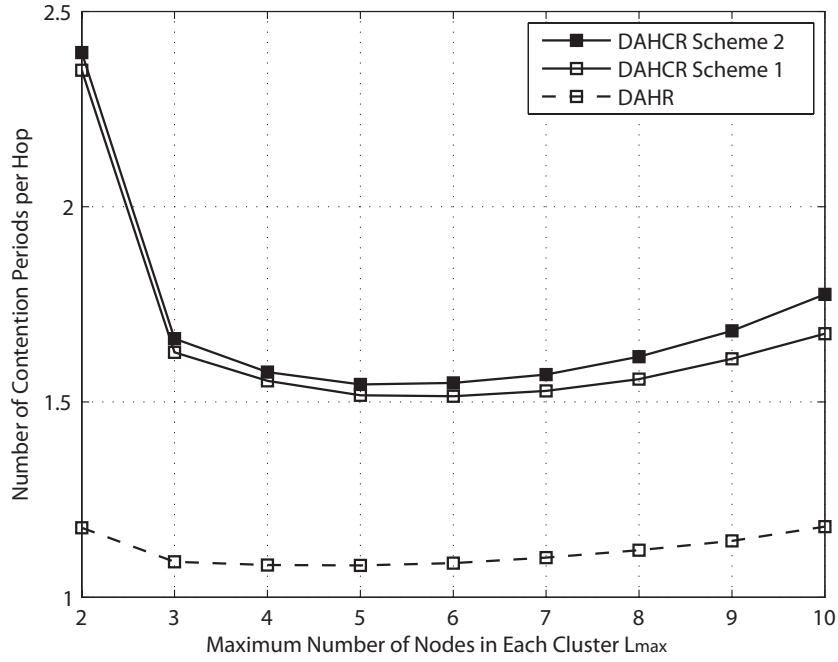

Figure 4.12: Number of contention periods per hop versus the maximum number of nodes in each cluster L_{max} of the distributed routing schemes with $\eta^p = 0.75$, $M = 10$, $\tau = 1.9$, and $k = 5$.

contention probability p_{low} may almost not send the CTS packet during the whole next contention period. As a result, it needs more contention periods to select the relay.

Figure 4.13 depicts the required transmission power versus the throughput τ of various routing schemes with $\eta^p = 0.75$, $M = 10$, $L_{max} = 5$, and $k = 5$. In the following, we state the amounts of improvements achieved at $\tau = 1.95$. When the cooperative diversity is applied with AHR, it saves the power by 39.62% and reduces the difference between the required transmission power of AHR and that of optimal routing by 72.92%. With respect to DAHR, the power reduction achieved by DAHCR scheme 1 is 58.52%. The cooperative diversity reduces the difference between the required transmission power of DAHR and that of AHR by 74.4%. DAHCR scheme 2 achieves the power saving of 24.62% compared to DAHCR

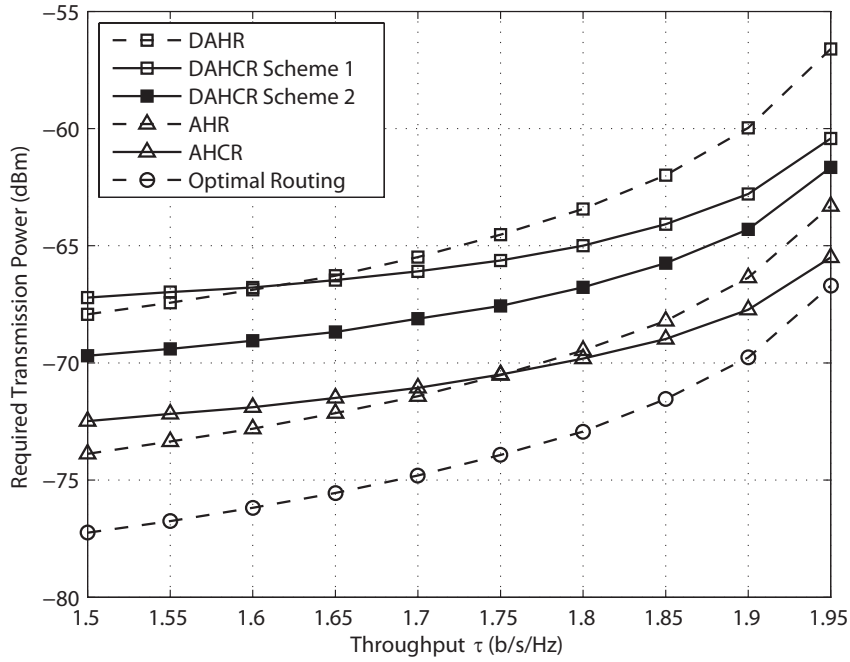

Figure 4.13: Required transmission power versus the throughput τ of various routing schemes with $\eta^p = 0.75$, $M = 10$, $L_{max} = 5$, and $k = 5$.

scheme 1 and further reduces the difference between the required transmission power of DAHR and that of AHR by 12.98%.

Figure 4.14 shows the number of contention periods per hop versus the throughput τ of the distributed routing schemes with $\eta^p = 0.75$, $M = 10$, $L_{max} = 5$, and $k = 5$. At $\tau = 1.95$, DAHCR scheme 1 increases the complexity by 50.28% compared to DAHR due to the selection of both the receiver and the relay. Besides, with respect to DAHCR scheme 1, DAHCR scheme 2 increases the complexity by 0.99%.

Figure 4.15 shows the required transmission energy of one transmission procedure per hop versus the data size of one transmission procedure of the distributed routing schemes with $\eta^p = 0.75$, $M = 10$, $L_{max} = 10$, and $\tau = 1.9$. According to the standard of the IEEE 802.11a, the control packets including the RTS packet, the CTS packet, the ACK packet, and the NACK packet are transmitted at 6 Mbps,

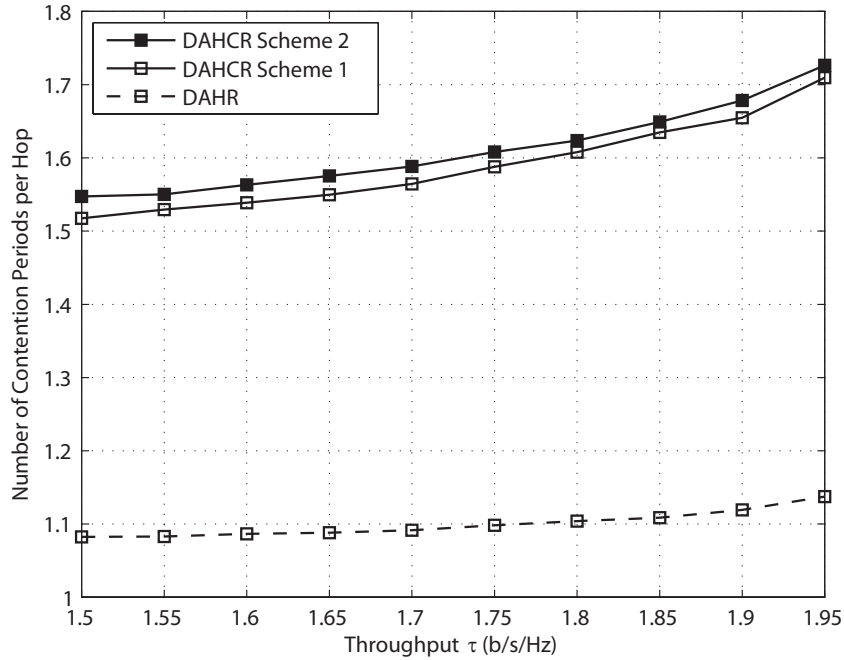

Figure 4.14: Number of contention periods per hop versus the throughput τ of the distributed routing schemes with $\eta^p = 0.75$, $M = 10$, $L_{max} = 5$, and $k = 5$.

and the transmission bandwidth is 20 MHz. Besides, the RTS packet size is 160 bits. The CTS packet size, the ACK packet size, and the NACK packet size are all 112 bits. We assume that the probability of success of transmitting the control packets is 0.99. By performing the calculation according to (4.10), we get that transmitting one control packet consumes 2.28×10^{-7} W. The transmission time can be calculated by dividing the transmission size by the transmission rate. Transmitting one RTS packet requires 2.67×10^{-5} s, and transmitting one CTS packet or one ACK packet or one NACK packet requires 1.87×10^{-5} s. The transmission energy can be calculated by multiplying the transmission power by the transmission time. Transmitting one RTS packet consumes 6.09×10^{-12} J, and transmitting one CTS packet or one ACK packet or one NACK packet consumes 4.26×10^{-12} J. From Fig. 4.15, we can observe that DAHCR scheme 2 outperforms DAHCR scheme 1, and DAHCR scheme 1 outperforms DAHR. DAHCR scheme 2 outperforms DAHCR

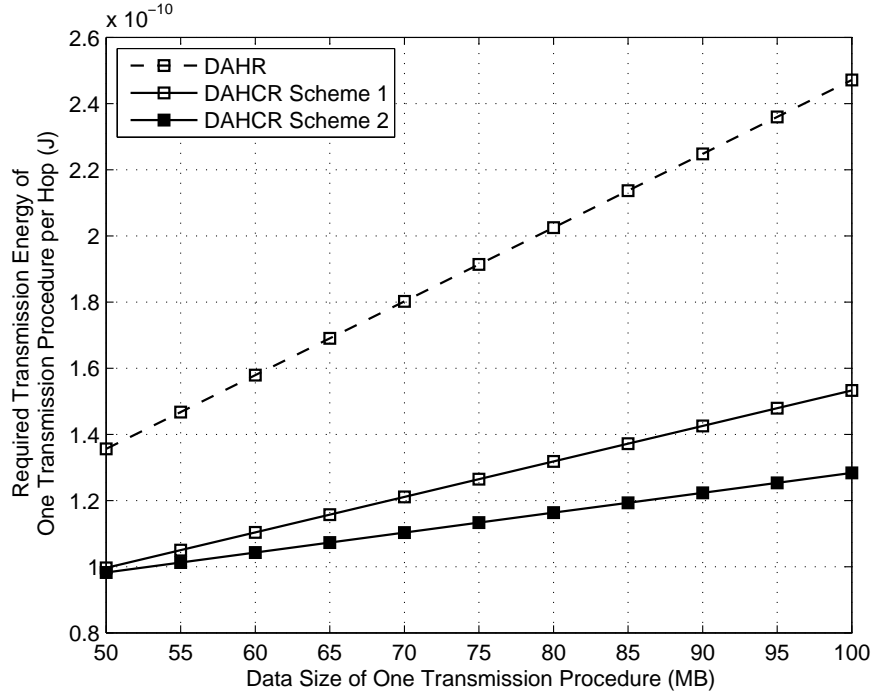

Figure 4.15: Required transmission energy of one transmission procedure per hop versus the data size of one transmission procedure of the distributed routing schemes with $\eta^p = 0.75$, $M = 10$, $L_{max} = 10$, and $\tau = 1.9$.

scheme 1 because the node with less required sender transmission power is given a higher contention probability, and the two nodes with the minimum and the second minimum required sender transmission power are selected as the receiver and the relay, respectively. DAHCR scheme 1 outperforms DAHR because the cooperative transmission is performed in DAHCR scheme 1. When the data size of one transmission procedure equals to 100 MB, DAHCR scheme 1 reduces the required transmission energy of one transmission procedure per hop by 37.98% compared to DAHR. Besides, DAHCR scheme 2 reduces the required transmission energy of one transmission procedure per hop by 16.25% compared to DAHCR scheme 1.

4.6 Conclusion

For AHR, AHCR has been presented to reduce the difference between the required transmission power of AHR and that of optimal routing. Besides, for DAHR, DAHCR scheme 1 has been proposed to reduce the difference between the required transmission power of DAHR and that of AHR. We then have addressed the problem of DAHCR scheme 1 and proposed DAHCR scheme 2. Simulation results show that in terms of the required transmission power, AHCR and DAHCR scheme 1 outperform AHR and DAHR, respectively. Besides, DAHCR scheme 2 outperforms DAHCR scheme 1. On the other hand, DAHCR scheme 1 increases the complexity by 43% compared to DAHR. Besides, DAHCR scheme 2 increases the complexity by 1.97% compared to DAHCR scheme 1.

Chapter 5

Primary Traffic Based Cooperative Routing with Preliminary Farthest Relay Selection in Cognitive Radio Ad Hoc Networks

5.1 Introduction

In Chapter 4, we consider the routing problem in cluster-based multihop networks. Although the diversity gain can be obtained in each hop, the number of hops from the source to the destination is fixed due to the cluster structure. As described in Subsection 1.5, when the number of hops is large, the end-to-end reliability degrades significantly. To minimize the number of hops, in cognitive radio ad hoc networks (CRAHN), farthest neighbor routing (FNR) algorithm using underlay access is proposed. However, in FNR, the primary traffic pattern is not considered, and it is assumed that the primary source (PS) is always transmitting data to the primary destination (PD). When the primary traffic pattern is considered in FNR, the coexistence of the primary and second traffic increases the number of cognitive relays on the multihop route. Thus, the end-to-end reliability degrades. To overcome this problem, a primary traffic based routing algorithm with cooperative transmission (PTBR-CT) is proposed. When the PS transmits data to the primary destination PD, besides the selected cognitive relay that receives data, another cognitive node is also selected as the cognitive relay that receives data of cognitive cooperative transmission. In the next time slot, when the PS still transmits data to the PD, cognitive cooperative transmission is performed to extend the shorter transmission distance caused by the coexistence of the primary and cognitive transmissions. On the other hand, when the PS has no data to transmit, the cognitive relay that receives data of the next hop transmission is selected, and the direct transmission is performed. The average number of cognitive relays on the route from the cognitive source (CS) to the cognitive destination (CD), the aver-

age end-to-end reliability, the average end-to-end throughput, the average required transmission power of transmitting data from the CS to the CD, and the average end-to-end transmission latency are investigated by computer simulations.

The rest of this chapter is organized as follows. In Section 5.2, the system model is described, and the description and analysis of the single hop cognitive transmission interfered by the PS and of the interference-free single hop cognitive transmission are presented. In addition, the description and analysis of the cognitive cooperative transmission interfered by the PS and the relaying algorithm are also presented. We investigate the performance of conventional primary traffic based farthest neighbor routing (PTBFNR) and proposed PTBR-CT in Section 5.3. In Section 5.4, this paper is concluded.

5.2 System Model

We consider an orthogonal frequency division multiple access (OFDMA) system that is mainly adopted in current cognitive radio networks. In each time slot of the OFDMA system, each primary user (PU) uses a pre-assigned frequency band to transmit data. When all the frequency bands are occupied by the PUs in different time slots, the cognitive user (CU) selects the same frequency band that is occupied by one of the PUs to transmit data. When an empty frequency band is available in a time slot, the CU uses it to transmit data. As a result, although there are multiple PUs, only one of them needs to be considered. Figure 5.1 shows an example of the spectrum usage of the OFDMA system. In this example, there are five frequency bands assigned with five PUs. Note that if the number of frequency bands is less than that of PUs, the condition that the PU has no frequency band to use may occur. Therefore, the number of frequency bands can not be less than that of PUs. In one time slot, first, the CU performs the signal detection in each frequency band to know if it is occupied by the PU. If there is an empty frequency band, the overlay access strategy is exploited, and the CU will use that empty frequency band to transmit data, e.g., time slots 1 and 4. Then, the signal detection terminates. If a

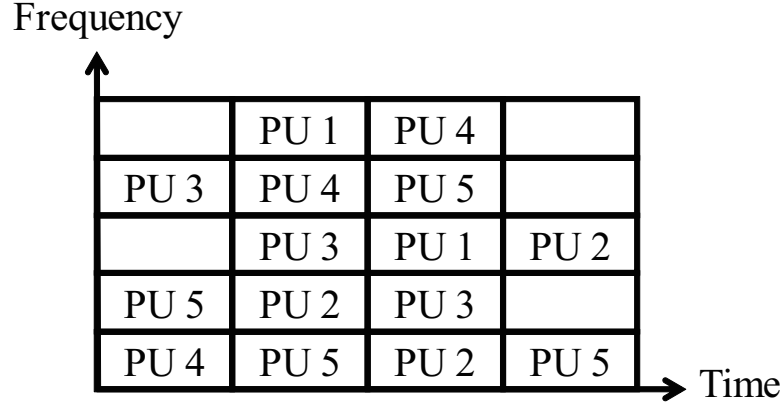

Figure 5.1: An example of the spectrum usage of the OFDMA system.

PU is detected to transmit data in a frequency band, and no transmission power of any PU is memorized in the CU, the CU will memorize the frequency band and the transmission power of that PU. If a PU with a pre-memorized transmission power is detected to transmit data in a frequency band, the CU will memorize that frequency band. After all frequency bands are examined, if all the frequency bands are occupied by the PSs, the underlay access strategy is exploited, and the CU will use the memorized frequency band to transmit data, e.g., time slots 2 and 3.

The network scenario shown in Fig. 5.2 is considered. It consists of a primary network (PN) and a CRAHN. In the PN, there are the PS and PD. In the CRAHN, there are the CS, the CD, and many other cognitive nodes. The cognitive nodes are uniformly distributed in a rectangular area. The CS and CD are assumed to be located on a line that is parallel to the x axis. Each node is assumed to have a single antenna because of the size and power constraints. The wireless channel fading is modeled by the short term Rayleigh fading. To distinguish between the relay of cooperative transmission and the general relay, the partner is used to represent the relay of cooperative transmission [81]. For the found route between the CS and CD, let M and N denote the number of cognitive relays and the number of cognitive partners, respectively. In Fig. 5.2, node A_i and node B_j represent the i th cognitive relay and the j th cognitive partner on the route, respectively, where $i = 1, 2, \dots, M$ and $j = 1, 2, \dots, N$. Let $d_{w,z}$ and $h_{w,z}$ denote the distance between node w and node

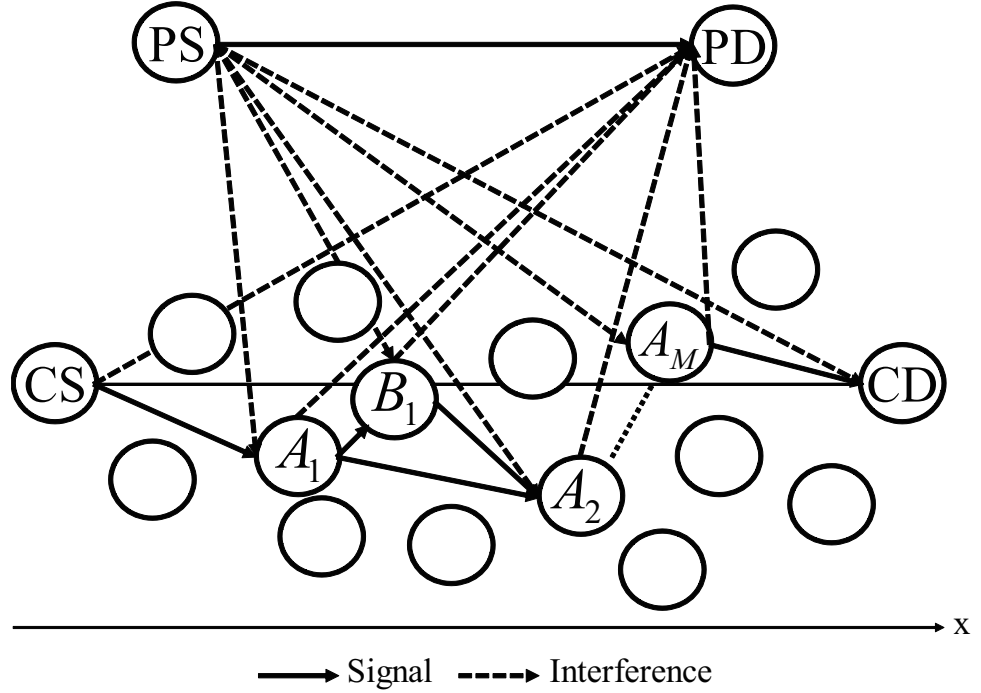

Figure 5.2: The primary transmission coexists with the multihop cognitive transmission.

z and the Rayleigh fading coefficients of the wireless channel between node w and node z , respectively. Let $n_{w,z}$ represent the additive noise measured at node z when node w is the sender and be modeled as a zero mean complex Gaussian random variable with variance N_0 .

We consider the interference from the cognitive relay that sends data and the cognitive partner at the PD and the interference from the PS at the cognitive partner and the cognitive relay that receives data. We do not consider the concurrency of the multihop relaying. We assume that at any time, data transmission occurs in only one hop that is between the cognitive relay that sends data and the cognitive relay that receives data or between the cognitive partner and the cognitive relay that receives data. As a result, at any time slot, only one cognitive relay that sends data or one cognitive partner interferes the PD. On the other hand, in any hop, the cognitive partner or the cognitive relay that receives data will be only interfered by the PS.

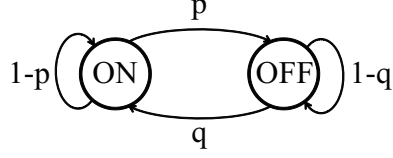

Figure 5.3: Two-state Markov chain process.

The successful reception probability of a packet is adopted to be the quality-of-service (QoS) metric. A packet is successfully received if the signal-to-interference-plus-noise ratio (SINR) observed at the receiver is higher than a certain threshold. In [79], when the wireless channel is modeled as the Rayleigh fading, the successful reception probability of a packet is derived as

$$\begin{aligned} \beta &= \Pr(\text{SINR} \geq \gamma) \\ &= \exp\left(-\frac{\gamma N_0}{P_0 d_0^{-\alpha}}\right) \times \prod_{u=1}^L \frac{1}{1 + \gamma \frac{P_u}{P_0} \left(\frac{d_0}{d_u}\right)^\alpha}, \end{aligned} \quad (5.1)$$

where γ is the SINR threshold, P_0 denotes the sender transmission power, d_0 represents the distance between the sender and receiver, α is the path loss exponent, L denotes the number of interferers, P_u represents the transmission power of the u th interferer, and d_u is the distance between the u th interferer and receiver.

We use the two-state Markov chain process shown in Fig. 5.3 to model the traffic pattern of the wireless link between the PS and PD. When the state is ON, the PS transmits data to the PD in the time slot. On the other hand, when the state is OFF, there is no data transmission between the PS and PD in the time slot. In Fig. 5.3, p and q denote the probability that the next state is OFF given that the current state is ON and the probability that the next state is ON given that the current state is OFF, respectively. The probability that the state is ON and the probability that the state is OFF can be calculated as $p_{on} = q/(p + q)$ and $p_{off} = p/(p + q)$, respectively.

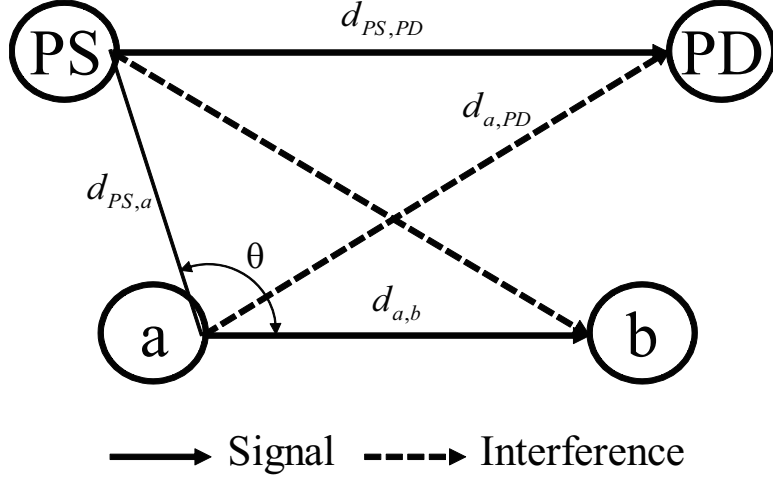

Figure 5.4: The primary transmission and the single hop cognitive transmission occur simultaneously.

5.3 Maximum Transmission Distance of the Single Hop Cognitive Transmission Interfered by the PS

Figure 5.4 depicts the scenario that the primary transmission and the single hop cognitive transmission occur simultaneously. In Fig. 5.4, node a and node b are the cognitive relay that sends data and the cognitive relay that receives data, respectively, and θ denotes $\angle(PS - a - b)$. The QoS requirement of the primary transmission interfered by the cognitive relay that sends data can be given by

$$\Pr(SINR_{PD} \geq \gamma_p) \geq \delta_p, \quad (5.2)$$

where $SINR_{PD}$ is the SINR observed at the PD, γ_p denotes the predefined SINR threshold of the primary transmission, and δ_p represents the QoS threshold of the primary transmission interfered by the cognitive users. When the PS transmits data to the PD, the transmission power of the cognitive relay that sends data must be lower than a certain threshold such that (5.2) can be satisfied. From (5.1), the successful reception probability of a packet at the PD that is interfered by the

cognitive relay that sends data can be written as

$$\Pr(\text{SINR}_{PD} \geq \gamma_p) = \frac{\exp\left(-\frac{\gamma_p N_0}{P_{PS} d_{PS,PD}^{-\alpha}}\right)}{1 + \gamma_p \frac{P_a}{P_{PS}} \left(\frac{d_{PS,PD}}{d_{a,PD}}\right)^\alpha}, \quad (5.3)$$

where P_{PS} and P_a are the transmission power of the PS and the cognitive relay that sends data, respectively. By substituting (5.3) into (5.2) and manipulating the equation, we can have

$$P_a \leq \frac{\beta_{SNR} - \delta_p}{\delta_p \gamma_p} \left(\frac{d_{a,PD}}{d_{PS,PD}}\right)^\alpha P_{PS}, \quad (5.4)$$

where

$$\beta_{SNR} = \exp\left(-\frac{\gamma_p N_0}{P_{PS} d_{PS,PD}^{-\alpha}}\right). \quad (5.5)$$

On the other hand, the QoS requirement of the single hop cognitive transmission interfered by the PS can be written as

$$\Pr(\text{SINR}_b \geq \gamma_c) \geq \delta_c, \quad (5.6)$$

where SINR_b is the SINR observed at the cognitive relay that receives data, γ_c denotes the predefined SINR threshold of the cognitive transmission, and δ_c represents the QoS threshold of the cognitive transmission. Subject to the constraint that the transmission power of the cognitive relay that sends data must be lower than a certain threshold shown in (5.4), there is a maximum value for the transmission distance of the cognitive relay that sends data such that (5.6) can be satisfied. By using the method in [65], the maximum transmission distance of the cognitive relay that sends data can be derived as

$$d_{a,b} \leq \frac{\eta d_{PS,a} \left(\eta \cos \theta - \sqrt{1 - \eta^2 \sin^2 \theta}\right)}{\eta^2 - 1}, \quad (5.7)$$

where

$$\eta = \left[\frac{\left(\delta_p - \exp\left(-\frac{\gamma_p N_0}{P_{PS} d_{PS,PD}^{-\alpha}}\right)\right) \log \delta_c}{\delta_p \gamma_p \gamma_c} \right]^{\frac{1}{\alpha}} \frac{d_{a,PD}}{d_{PS,PD}}. \quad (5.8)$$

In order to reduce the number of cognitive relays as many as possible, the transmission power of the cognitive relay that sends data is defined as

$$P_a = \frac{\beta_{SNR} - \delta_p}{\delta_p \gamma_p} \left(\frac{d_{a,PD}}{d_{PS,PD}}\right)^\alpha P_{PS}. \quad (5.9)$$

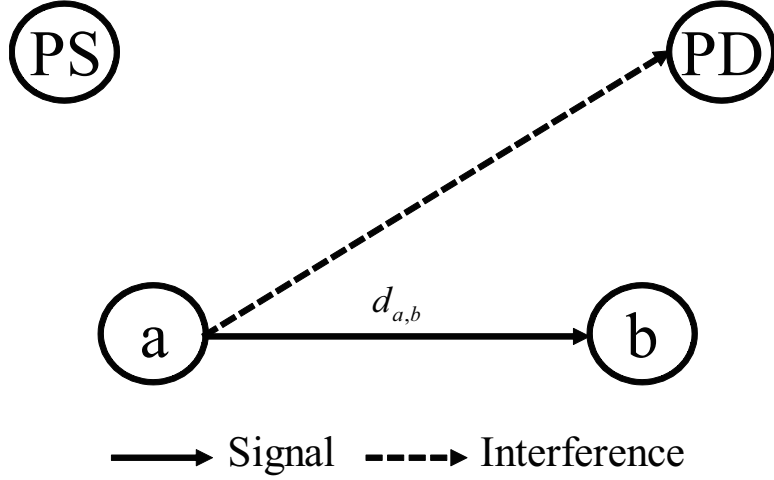

Figure 5.5: The PS remains silent when the single hop cognitive transmission occurs.

5.4 Maximum Transmission Distance of the Interference-Free Single Hop Cognitive Transmission

Figure 5.5 illustrates the scenario that the PS remains silent when the single hop cognitive transmission occurs. When the PS remains silent, although, at the PD, there is the interference caused by the cognitive relay that sends data, the transmission power of the cognitive relay that sends data has no upper bound because it is not needed to consider the QoS requirement of the primary transmission interfered by the cognitive relay that sends data. When the PS remains silent, the cognitive relay that sends data uses the predefined transmission power to transmit data to the cognitive relay that receives data. The QoS requirement of the interference-free single hop cognitive transmission can be given by

$$\Pr(SNR_b \geq \gamma_c) \geq \delta_c, \quad (5.10)$$

where SNR_b is the signal-to-noise ratio (SNR) observed at the cognitive relay that receives data. Besides, we know that under the Rayleigh fading, the successful reception probability of a packet at the cognitive relay that receives data can be written as

$$\Pr(SNR_b \geq \gamma_c) = \exp\left(-\frac{\gamma_c N_0}{P_c d_{a,b}^\alpha}\right), \quad (5.11)$$

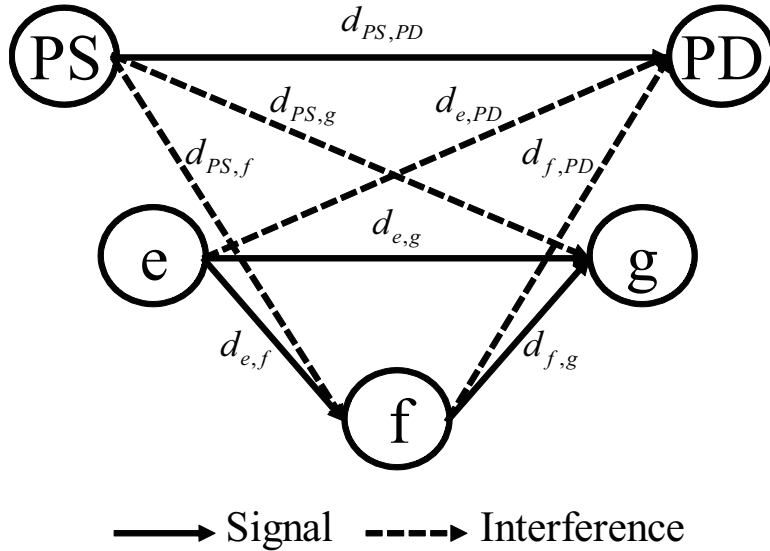

Figure 5.6: The primary transmission and the cognitive cooperative transmission occur simultaneously.

where P_c is the transmission power of the cognitive relay that sends data of the interference-free single hop cognitive transmission. When the cognitive relay that sends data uses P_c to transmit data to the cognitive relay that receives data, the transmission distance of the cognitive relay that sends data must be lower than a certain threshold such that (5.10) can be satisfied. By substituting (5.11) into (5.10) and manipulating the equation, we can obtain

$$d_{a,b} \leq \left(-\frac{P_c \log \delta_c}{\gamma_c N_0} \right)^{\frac{1}{\alpha}}. \quad (5.12)$$

5.5 Cognitive Cooperative Transmission Interfered by the PS

The scenario that the primary transmission and cognitive cooperative transmission occur simultaneously is shown in Fig. 5.6. In Fig. 5.6, node e , node f , and node g are the cognitive relay that sends data, the cognitive partner, and the cognitive relay that receives data, respectively. The decode-and-forward incremental relaying protocol proposed in [30] is employed to implement cooperative transmission that consists of two time slots. The cognitive relay that sends data transmits

data to the cognitive relay that receives data in the first time slot. The data can also be received by the cognitive partner because of the broadcast nature of the wireless channel. In the first time slot, when cognitive cooperative transmission is interfered by the PS, the received signal at the cognitive relay that receives data and the cognitive partner can be written as

$$y_{g,1} = \sqrt{P_e d_{e,g}^{-\alpha}} h_{e,g} s_e + \sqrt{P_{PS} d_{PS,g}^{-\alpha}} h_{PS,g} s_{PS} + n_{e,g} \quad (5.13)$$

and

$$y_f = \sqrt{P_e d_{e,f}^{-\alpha}} h_{e,f} s_e + \sqrt{P_{PS} d_{PS,f}^{-\alpha}} h_{PS,f} s_{PS} + n_{e,f}, \quad (5.14)$$

respectively, where P_e is the transmission power of the cognitive relay that sends data, and s_e and s_{PS} denote the transmitted data signals of the cognitive relay that sends data and the PS, respectively. At the cognitive relay that receives data, after the data is received, the decoding process is performed. If the SINR observed at the cognitive relay that receives data exceeds the predefined threshold, the decoding is successful. When the cognitive relay that receives data fails to decode the received data, it informs the cognitive partner to request the transmission of the same data from the cognitive relay that sends data. When the cognitive relay that receives data succeeds in decoding the received data, it informs the success of the decoding to the cognitive relay that sends data and the cognitive partner. When the cognitive partner successfully decodes the data received from the cognitive relay that sends data, the data is transmitted to the cognitive relay that receives data by the cognitive partner in the second time slot. When the PS interferes cognitive cooperative transmission, the received signal at the cognitive relay that receives data in the second time slot can be given by

$$y_{g,2} = \sqrt{P_f d_{f,g}^{-\alpha}} h_{f,g} s_f + \sqrt{P_{PS} d_{PS,g}^{-\alpha}} h_{PS,g} s_{PS} + n_{f,g}, \quad (5.15)$$

where P_f is the transmission power of the cognitive partner, and s_f denotes the transmitted data signal of the cognitive partner.

5.6 Successful Reception Probability of a Packet of Cognitive Cooperative Transmission Interfered by the PS

We use the scheme in [40] to derive the successful reception probability of a packet of cognitive cooperative transmission interfered by the PS. The failed reception probability of a packet of cognitive cooperative transmission interfered by the PS can be written as

$$p_g^F = \Pr(\text{failure} | SINR_{g,1} < \gamma_c) \times \Pr(SINR_{g,1} < \gamma_c), \quad (5.16)$$

where $SINR_{g,1}$ is the SINR observed at the cognitive relay that receives data after the data transmitted from the cognitive relay that sends data is received at the cognitive relay that receives data in the first time slot. The conditional failure probability in the right hand side of (5.16) can be given by

$$\begin{aligned} \Pr(\text{failure} | SINR_{g,1} < \gamma_c) &= \Pr(SINR_f < \gamma_c) \\ &+ \Pr(SINR_f \geq \gamma_c) \\ &\times \Pr(SINR_{g,2} < \gamma_c | SINR_{g,1} < \gamma_c), \end{aligned} \quad (5.17)$$

where $SINR_f$ is the SINR observed at the cognitive partner after the cognitive partner receives the data transmitted from the cognitive relay that sends data in the first time slot, and $SINR_{g,2}$ denotes the SINR observed at the cognitive relay that receives data after the data sent from the cognitive partner is received at the cognitive relay that receives data in the second time slot. Due to the independence between the events $SINR_{g,2} < \gamma_c$ and $SINR_{g,1} < \gamma_c$, (5.16) can be written as

$$\begin{aligned} \Pr(\text{failure} | SINR_{g,1} < \gamma_c) &= \Pr(SINR_f < \gamma_c) \\ &+ \Pr(SINR_f \geq \gamma_c) \times \Pr(SINR_{g,2} < \gamma_c). \end{aligned} \quad (5.18)$$

By substituting (5.18) into (5.16), we can get

$$\begin{aligned} p_g^F &= \Pr(SINR_f < \gamma_c) \times \Pr(SINR_{g,1} < \gamma_c) \\ &+ \Pr(SINR_f \geq \gamma_c) \times \Pr(SINR_{g,2} < \gamma_c) \\ &\times \Pr(SINR_{g,1} < \gamma_c). \end{aligned} \quad (5.19)$$

Let p_g^S denote the successful reception probability of a packet of cognitive cooperative transmission interfered by the PS. By substituting $p_g^F = 1 - p_g^S$ into (5.19) and using $\Pr(X < l) = 1 - \Pr(X \geq l)$, we can obtain

$$\begin{aligned} p_g^S &= \Pr(\text{SINR}_{g,1} \geq \gamma_c) + \Pr(\text{SINR}_f \geq \gamma_c) \\ &\quad \times \Pr(\text{SINR}_{g,2} \geq \gamma_c) - \Pr(\text{SINR}_f \geq \gamma_c) \\ &\quad \times \Pr(\text{SINR}_{g,2} \geq \gamma_c) \times \Pr(\text{SINR}_{g,1} \geq \gamma_c), \end{aligned} \quad (5.20)$$

where

$$\Pr(\text{SINR}_{g,1} \geq \gamma_c) = \frac{\exp\left(-\frac{\gamma_c N_0}{P_e d_{e,g}^{-\alpha}}\right)}{1 + \gamma_c \frac{P_{PS}}{P_e} \left(\frac{d_{e,g}}{d_{PS,g}}\right)^\alpha}, \quad (5.21)$$

$$\Pr(\text{SINR}_f \geq \gamma_c) = \frac{\exp\left(-\frac{\gamma_c N_0}{P_e d_{e,f}^{-\alpha}}\right)}{1 + \gamma_c \frac{P_{PS}}{P_e} \left(\frac{d_{e,f}}{d_{PS,f}}\right)^\alpha}, \quad (5.22)$$

and

$$\Pr(\text{SINR}_{g,2} \geq \gamma_c) = \frac{\exp\left(-\frac{\gamma_c N_0}{P_f d_{f,g}^{-\alpha}}\right)}{1 + \gamma_c \frac{P_{PS}}{P_f} \left(\frac{d_{f,g}}{d_{PS,g}}\right)^\alpha}. \quad (5.23)$$

Satisfying the QoS requirement of the primary transmission interfered by the CU introduces the maximum value of the transmission power of the cognitive relay that sends data and the cognitive partner. By using the method described in Section 5.2, the transmission power of the cognitive relay that sends data and the cognitive partner can be upper bounded by

$$P_e \leq \frac{\beta_{SNR} - \delta_p}{\delta_p \gamma_p} \left(\frac{d_{e,PD}}{d_{PS,PD}}\right)^\alpha P_{PS} \quad (5.24)$$

and

$$P_f \leq \frac{\beta_{SNR} - \delta_p}{\delta_p \gamma_p} \left(\frac{d_{f,PD}}{d_{PS,PD}}\right)^\alpha P_{PS}, \quad (5.25)$$

respectively. In order to reduce the number of cognitive relays as many as possible, the transmission power of the cognitive relay that sends data and the cognitive partner is defined as

$$P_e = \frac{\beta_{SNR} - \delta_p}{\delta_p \gamma_p} \left(\frac{d_{e,PD}}{d_{PS,PD}}\right)^\alpha P_{PS} \quad (5.26)$$

and

$$P_f = \frac{\beta_{SNR} - \delta_p}{\delta_p \gamma_p} \left(\frac{d_{f,PD}}{d_{PS,PD}} \right)^\alpha P_{PS}, \quad (5.27)$$

respectively.

5.7 Spectral Efficiency and Transmission Power of Cognitive Cooperative Transmission Interfered by the PS

The occurrence probability of the event that both the cognitive relay that sends data and the cognitive partner transmit can be given by

$$\begin{aligned} p_{e,f} &= \Pr(SINR_f \geq \gamma_c) - \Pr(SINR_f \geq \gamma_c) \\ &\quad \times \Pr(SINR_{g,1} \geq \gamma_c). \end{aligned} \quad (5.28)$$

The occurrence probability of the event that only the cognitive relay that sends data transmits can be written as

$$p_e = 1 - p_{e,f}. \quad (5.29)$$

Let R denote the spectral efficiency of direct transmission. When both the cognitive relay that sends data and the cognitive partner transmit, the spectral efficiency is $R/2$ because two time slots are used for data transmission, and the transmission power is $P_e + P_f$. When only the cognitive relay that sends data transmits, the spectral efficiency and transmission power are R and P_e , respectively. The spectral efficiency and transmission power of cognitive cooperative transmission can be given by

$$R_{e,f,g} = \frac{R}{2} \times p_{e,f} + R \times p_e \quad (5.30)$$

and

$$P_{e,f,g} = (P_e + P_f) \times p_{e,f} + P_e \times p_e, \quad (5.31)$$

respectively. By substituting (5.29) into (5.30) and (5.31) and manipulating the equations, we can have

$$R_{e,f,g} = R \times \left(1 - \frac{p_{e,f}}{2} \right) \quad (5.32)$$

and

$$P_{e,f,g} = P_f \times p_{e,f} + P_e. \quad (5.33)$$

5.8 Routing Algorithm

We assume that each cognitive node is equipped with the global positioning system (GPS), and there is a central control unit collecting all the required information to perform the relaying algorithm. The route from the CS to the CD is established by a hop-by-hop fashion. The calculation formula of the maximum transmission distance of the cognitive relay is decided based on the traffic status of the wireless link between the PS and the PD. If the PS is transmitting data to the PD, the maximum transmission distance of the cognitive relay is calculated according to (5.7). On the other hand, if the PS has no data to transmit to the PD, the maximum transmission distance is calculated according to (5.12). Among the cognitive nodes whose x coordinates are larger than the x coordinate of the cognitive relay that sends data and hop distances are less than or equal to the maximum transmission distance calculated according to (5.7) or (5.12), the cognitive node that is farthest away from the cognitive relay that sends data is selected as the cognitive relay that receives data. Note that the hop distance of a cognitive node is defined as the distance between that cognitive node and the cognitive relay that sends data. When the PS is transmitting data to the PD, in addition to the cognitive relay that receives data, another cognitive node is selected for cooperative transmission in advance. Cooperative transmission will be performed if the PS still transmits data to the PD when the cognitive relay that sends data (the founded cognitive relay that receives data) finds the cognitive relay that receives data in the next hop. The flow chart of the routing algorithm is shown in Fig. 5.7. In addition, the detailed routing algorithm is described as follows.

- Initialization steps:

1. Let E_{A_i} and E_{B_j} denote the sets of the cognitive nodes whose x coordinates are larger than the x coordinate of A_i except the CD and of B_j

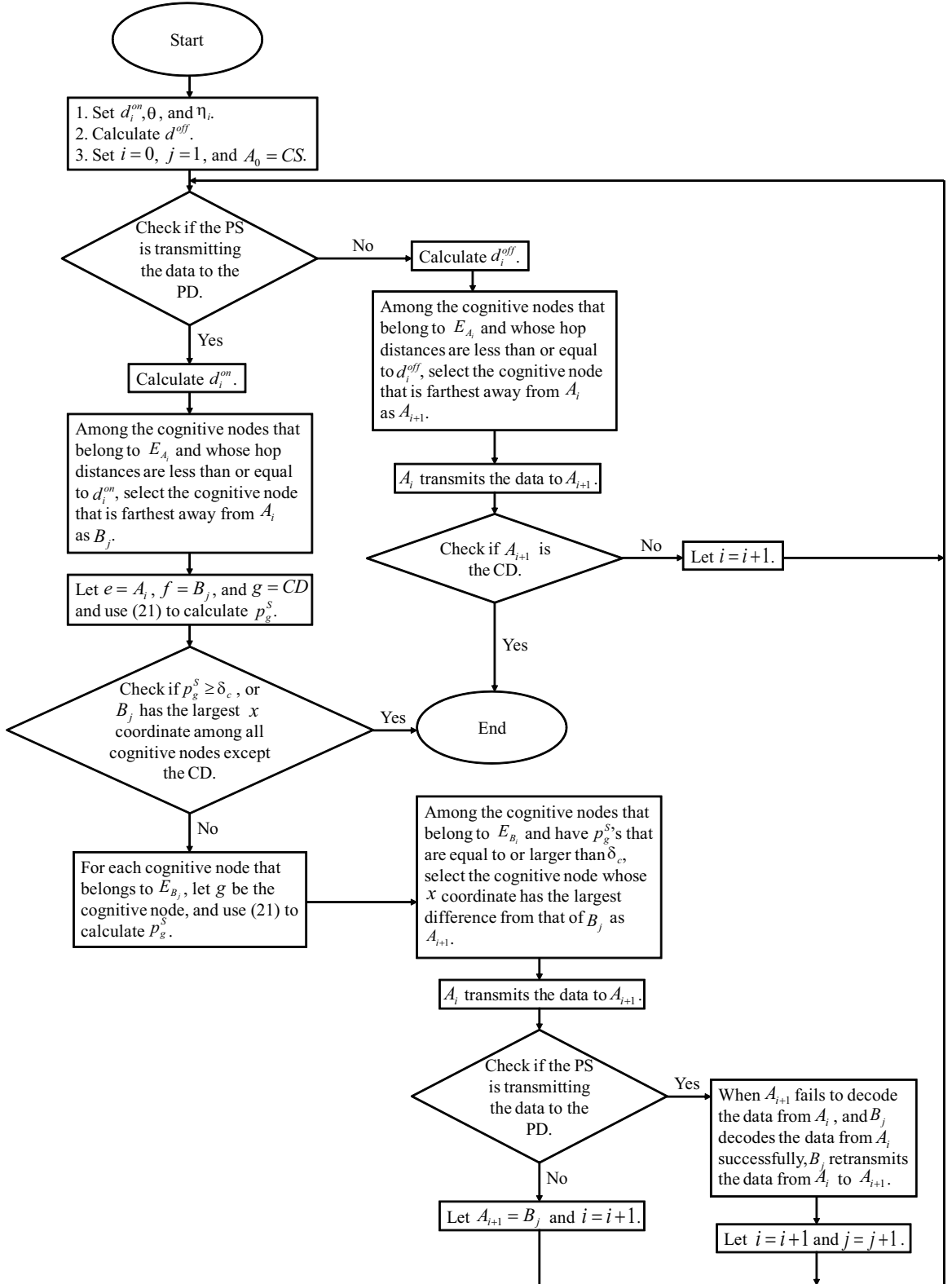

Figure 5.7: Flow chart of the routing algorithm.

except the CD, respectively.

2. Let

$$d_i^{on} = \frac{\eta_i d_{A_i, PS} \left(\eta_i \cos \theta_i - \sqrt{1 - \eta_i^2 \sin^2 \theta_i} \right)}{\eta_i^2 - 1}, \quad (5.34)$$

where $\theta = \angle(PS - A_i - CD)$ and

$$\eta_i = \left[\frac{\left(\delta_p - \exp \left(-\frac{\gamma_p N_0}{P_{PS} d_{PS, PD}^\alpha} \right) \right) \log \delta_c}{\delta_p \gamma_p \gamma_c} \right]^{\frac{1}{\alpha}} \times \frac{d_{A_i, PD}}{d_{PS, PD}}. \quad (5.35)$$

3. Set $i = 0$, $j = 1$, and $A_0 = CS$, and calculate

$$d^{off} = \left(-\frac{P_c \log \delta_c}{\gamma_c N_0} \right)^{\frac{1}{\alpha}}. \quad (5.36)$$

• Iteration steps:

1. Check if the PS is transmitting data to the PD. If not, let $k = 0$, and go to step 8. Otherwise, let $k = 1$, and calculate d_i^{on} by using (5.34).
2. Among the cognitive nodes that belong to E_{A_i} and whose hop distances are less than or equal to d_i^{on} , select the cognitive node that is farthest away from A_i as B_j . If B_j is the CD, or no cognitive node can be found, go to step 9. Otherwise, go to the next step.
3. Let $e = A_i$, $f = B_j$, and $g = CD$ and use (5.20) to calculate p_g^S . If $p_g^S \geq \delta_c$, or B_j has the largest x coordinate among all the cognitive nodes except the CD, go to step 9. Otherwise, go to the next step.
4. For each cognitive node that belongs to E_{B_j} , let g be the cognitive node, and use (5.20) to calculate p_g^S .
5. Among the cognitive nodes that belong to E_{B_j} and have p_g^S 's that are equal to or larger than δ_c , select the cognitive node whose x coordinate

has the largest difference from that of B_j as A_{i+1} . If no cognitive node can be found, terminate. Otherwise, let A_i use P_e to transmit data to A_{i+1} .

6. Check if the PS is transmitting data to the PD. If so, go to the next step. Otherwise, let $A_{i+1} = B_j$ and $i = i + 1$, and return to step 1 of the iteration steps.
7. When A_{i+1} fails to decode the data from A_i , and B_j decodes the data from A_i successfully, let B_j use P_f to retransmit the data from A_i to A_{i+1} . Let $i = i + 1$ and $j = j + 1$, and return to step 1 of the iteration steps.
8. Among the cognitive nodes that belong to E_{A_i} and whose hop distances are less than or equal to d^{off} , select the one that is farthest away from A_i as A_{i+1} . If A_{i+1} is the CD, or no node can be found, go to the next step. Otherwise, let A_i use P_c to transmit data to A_{i+1} , let $i = i + 1$, and return to step 1 of the iteration steps.
9. If $k = 1$, go to the next step. Otherwise, go to step 13.
10. If B_j exists and is not the CD, go to the next step. Otherwise, go to step 12.
11. Let A_i use P_e to transmit data to the CD. When the CD fails to decode the data from A_i , and B_j decodes the data from A_i successfully, let B_j use P_f to retransmit the data from A_i to the CD.
12. If B_j exists and is the CD, let A_i use P_a to transmit data to the CD. Otherwise, terminate.
13. If A_{i+1} exists, let A_i use P_c to transmit data to the CD. Otherwise, terminate.

As shown in Section 2.2, d_i^{on} is derived subject to that the QoS requirements of both the primary transmission interfered by the cognitive relay that sends data and the single hop cognitive transmission interfered by the PS are satisfied. Therefore,

although B_j selected in step 2 of the iteration steps may be close to the PS, the QoS requirement of the single hop cognitive transmission interfered by the PS will be satisfied at B_j . The cooperative partner selection is illustrated in Fig. 5.8. In PTBR-CT, cooperative transmission is used to extend the shorter transmission distance caused by that the ON state of the primary traffic occurs two times continuously. If the primary traffic is ON in the first time slot, d_i^{on} that denotes the maximum transmission distance of the single hop cognitive transmission interfered by the PS is calculated according to (5.34), and from the cognitive nodes whose hop distances are less than or equal to d_i^{on} , the one that is farthest away from A_i is selected as B_j . In addition, A_{i+1} is selected for cooperative transmission. Then, data is broadcasted from A_i to B_j and A_{i+1} . If the second time slot of the primary traffic is also ON, the requirement of the data retransmission is checked. If A_{i+1} fails to decode the data, and B_j decodes the data successfully, B_j retransmits the data to A_{i+1} . If the second time slot of the primary traffic is OFF, because cooperative transmission is not performed, A_{i+1} is replaced by B_j , and B_j is released. Then, from the cognitive nodes whose hop distances are less than or equal to d^{off} that denotes the maximum transmission distance of the interference-free single hop cognitive transmission, the one that is farthest away from A_{i+1} is selected as A_{i+2} . Finally, data is transmitted from A_{i+1} to A_{i+2} .

Figure 5.9 shows an example of the relaying algorithm. Node A_i and node B_j denote the i th cognitive relay and the j th cognitive partner on the route from the CS to the CD, respectively, where $i = 1, 2, \dots, 5$ and $j = 1$. Because the primary traffic is ON in the first time slot, in addition to B_1 , A_1 is selected and prepared for performing cooperative transmission. However, cooperative transmission is not performed because the primary traffic is OFF in the second time slot. Consequently, A_1 is replaced by B_1 , and B_1 is released. In the fourth time slot, as the same as the first time slot, in addition to B_1 , A_4 is also selected and prepared for performing cooperative transmission. Different from the second time slot, the primary traffic is ON in the fifth time slot. Therefore, when A_4 decodes the data from A_3 successfully, A_4 requests the central control unit to inform the success of the decoding to A_3 and

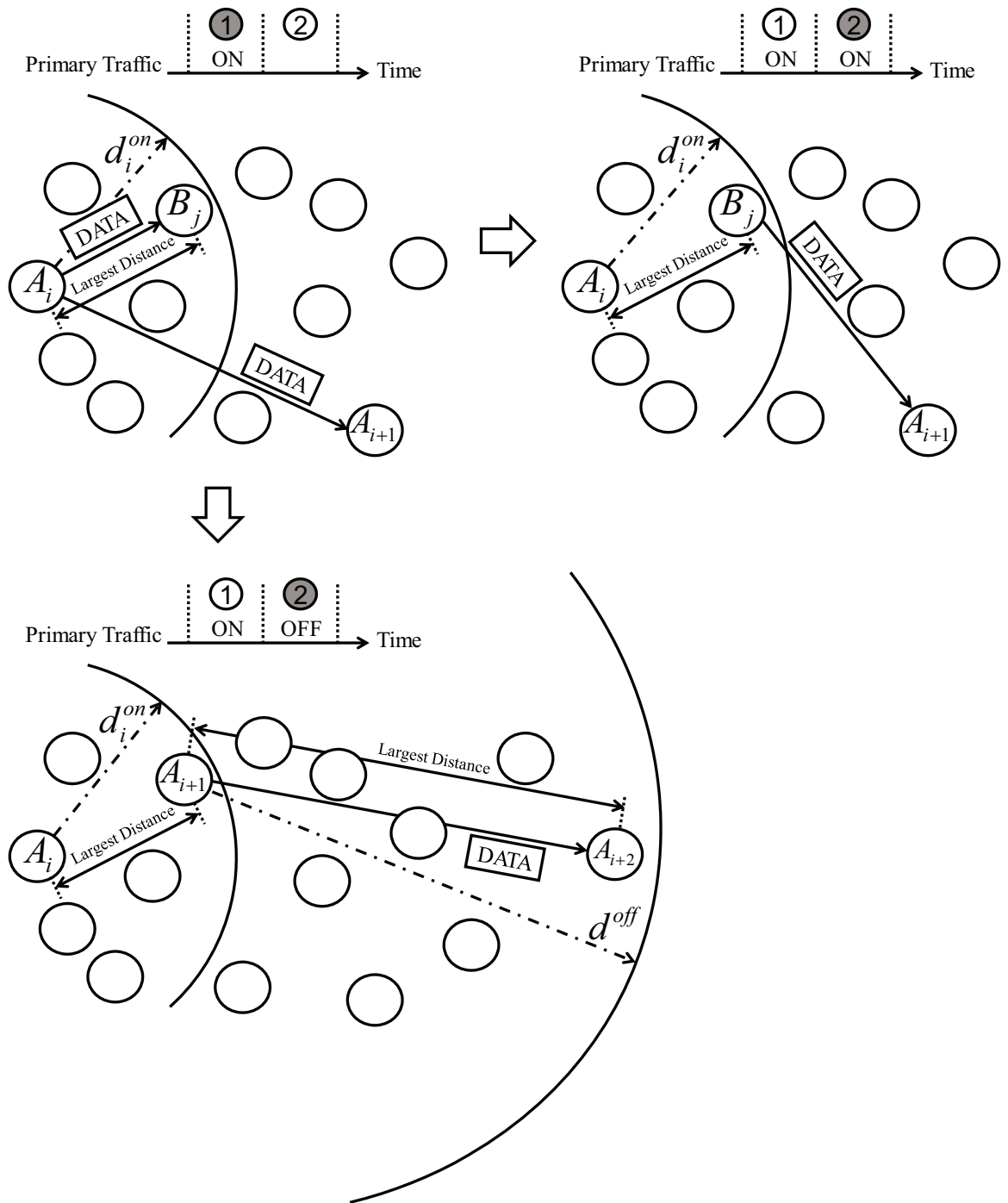

Figure 5.8: Cooperative relay selection.

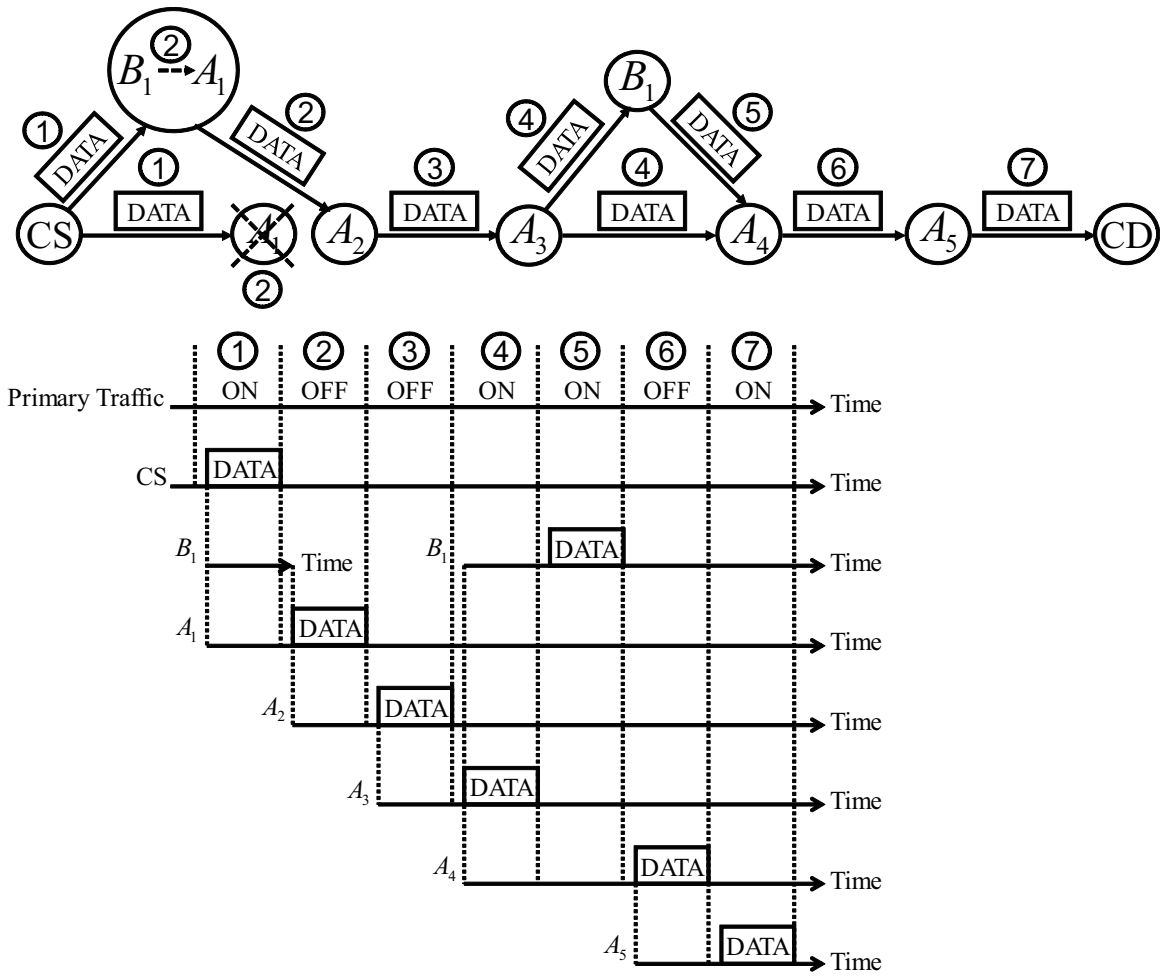

Figure 5.9: An example of the routing algorithm.

B_1 . Oppositely, when A_4 fails in the decoding of the data from A_3 , it requests the central control unit to inform B_1 to retransmit that data. When B_1 decodes the data from A_3 successfully, it transmits that data to A_4 . In the third and sixth time slot, because the primary traffic is OFF, no cognitive relay will be selected. In the seventh time slot, although the primary traffic is ON, because the pre-selected cognitive relay is the CD, direct transmission is performed. Therefore, on the multihop route from the CS to the CD, there is only one relay node B_1 that is selected in the fourth time slot. According to the IEEE 802.11a standard, the maximum length of the medium access control (MAC) data frame is 2346 bytes, and the transmission bandwidth is 20 MHz. Here, we assume that the spectral efficiency of direct transmission is 2 b/s/Hz, and one IEEE 802.11a MAC data frame with the maximum length is transmitted in one time slot. Therefore, by dividing the maximum length of one IEEE 802.11a MAC data frame by the multiplication of the spectral efficiency and bandwidth, we can have that the length of one time slot is 0.4692 ms.

5.9 Performance Evaluation

We conduct computer simulations to investigate the average number of cognitive relays on the route from the CS to the CD of PTBFNR and PTBR-CT. In addition, the performance of PTBFNR and PTBR-CT in terms of the average end-to-end reliability, the average end-to-end throughput, the average required transmission power of transmitting the data from the CS to the CD, and the average end-to-end transmission latency are also evaluated. The coordinates of the PS, the PD, the CS, and the CD are $(0, d_{PS,CS} + 50)$, $(d_{PS,PD}, d_{PS,CS} + 50)$, $(0, 50)$, and $(d_{CS,CD}, 50)$, respectively. In a rectangular area, the other cognitive nodes are uniformly distributed. The coordinates of the vertices of the rectangular area are $(0, 0)$, $(0, 100)$, $(d_{CS,CD}, 0)$, and $(d_{CS,CD}, 100)$. According to (5.9), (5.26), and (5.27), the transmission power of the cognitive relays that send data of the single hop and cooperative transmissions and that of the cognitive partner of cooperative transmission depend on the distance between them and the PD. Therefore, to let P_c be the

Table 5.1: Simulation Parameters.

parameter	value
SINR thresholds γ_p and γ_c	3
noise power N_0	-100 dBm
distance $d_{PS,PD}$	350m
distance $d_{CS,CD}$	500m
QoS threshold δ	0.95
QoS thresholds δ_p and δ_c	0.9
number of nodes	500
spectral efficiency	
of direct transmission R	2 b/s/Hz

maximum transmission power of the cognitive relay, we define it as

$$P_c = \begin{cases} \frac{\beta_{SNR} - \delta_p}{\delta_p \gamma_p} \left(\frac{\sqrt{d_{PS,PD}^2 + (d_{PS,CS}^{max} + 50)^2}}{d_{PS,PD}} \right)^\alpha P_{PS}, & \text{if } d_{PS,PD} \geq \frac{d_{CS,CD}}{2}, \\ \frac{\beta_{SNR} - \delta_p}{\delta_p \gamma_p} \left(\frac{\sqrt{(d_{CS,CD} - d_{PS,PD})^2 + (d_{PS,CS}^{max} + 50)^2}}{d_{PS,PD}} \right)^\alpha P_{PS}, & \\ \text{otherwise,} & \end{cases} \quad (5.37)$$

where $d_{PC,CS}^{max}$ denotes the maximum distance between the PS and the CS. The transmission power of the PS is defined as

$$P_{PS} = -\frac{\gamma_p N_0}{d_{PS,PD}^{-\alpha} \log \delta}, \quad (5.38)$$

where δ is the QoS threshold of the interference-free primary transmission. Simulation parameters are listed in Table 5.1. Simulation results are averaged over 10000 network scenarios.

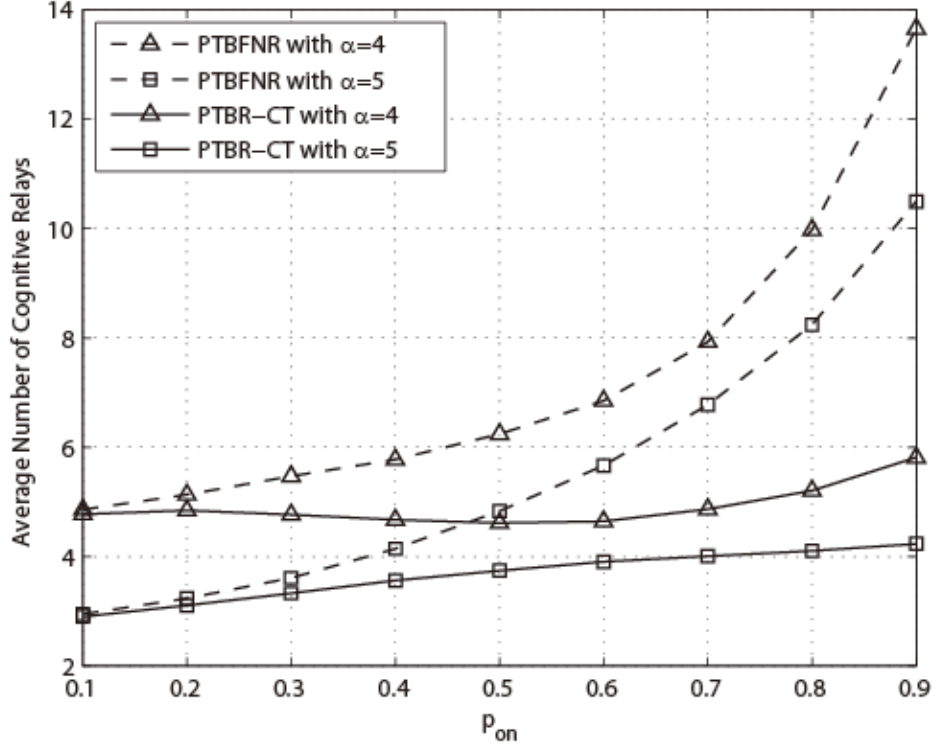

Figure 5.10: Average number of cognitive relays versus the probability that the PS is transmitting data to the PD for $d_{PS,CS} = 200\text{m}$.

Figure 5.10 shows the average number of cognitive relays on the route from the CS to the CD versus the probability that the PS is transmitting data to the PD. From Fig. 5.10, we can observe that the average numbers of cognitive relays of PTBFNR with $\alpha = 4$ and $\alpha = 5$ increase when p_{on} increases from 0.1 to 0.9. The reason is described as follows. When p_{on} increases, the number of times that the single hop cognitive transmission and the primary transmission occur simultaneously also increases. Consequently, more shorter maximum transmission distances are used to find the cognitive relays that receive data. The shorter maximum transmission distances in more hops results in an increase of the average number of cognitive relays. It is also shown that when p_{on} increases from 0.1 to 0.9, the difference between the average numbers of cognitive relays of PTBFNR and PTBR-CT increases at $\alpha = 4$ and $\alpha = 5$. This phenomenon can be explained as follows. When p_{on} increases,

cooperative transmission is exploited in more hops. Thus, x coordinates of more cognitive relays that receive data are enlarged. This results in an increase of the difference between the average numbers of cognitive relays of PTBFNR and PTBR-CT. As a result, when p_{on} increases, and the increasing amount of the difference between the average numbers of cognitive relays of PTBFNR and PTBR-CT is larger than the increasing amount of the average number of cognitive relays of PTBFNR, the average number of cognitive relays of PTBR-CT will decrease. This condition occurs from $p_{on} = 0.2$ to $p_{on} = 0.5$. From Fig. 5.10, we can observe that PTBR-CT reduces the average number of cognitive relays compared to PTBFNR at $\alpha = 4$ and $\alpha = 5$ for $d_{PS,CS} = 200\text{m}$. This is caused by that cooperative transmission is used to enlarge the x coordinate of the cognitive relay.

Figure 5.11 shows the average number of cognitive relays on the route from the CS to the CD versus the distance between the PS and the CS. It is shown that when $d_{PS,CS}$ increases from 100m to 300m, the average numbers of cognitive relays of PTBFNR and PTBR-CT with $\alpha = 4$ and $\alpha = 5$ decrease. The reason is described as follows. According to the node distribution of our simulation, when $d_{PS,CS}$ increases, the distances between each cognitive relay and the PD and between each cognitive partner and the PD increase. According to (5.9), (5.26), and (5.27), the transmission power of each cognitive relay and that of each cognitive partner increase when the distances between them and the PD increase, and other parameters remain the same. Therefore, when $d_{PS,CS}$ increases, each cognitive relay and each cognitive partner use larger power to transmit data. This causes that subject to the QoS requirement of the cognitive transmission, the maximum transmission distance of each cognitive relay that sends data of the single hop transmission becomes longer, and a cognitive relay that receives data and is with a larger x coordinate can be selected for cooperative transmission. This two consequences decrease the number of cognitive relays on the route. It is also shown that compared to PTBFNR, the average number of cognitive relays is reduced by PTBR-CT at $\alpha = 4$ and $\alpha = 5$ for $p_{on} = 0.7$. This is because the x coordinate of the cognitive relay is increased by cooperative transmission.

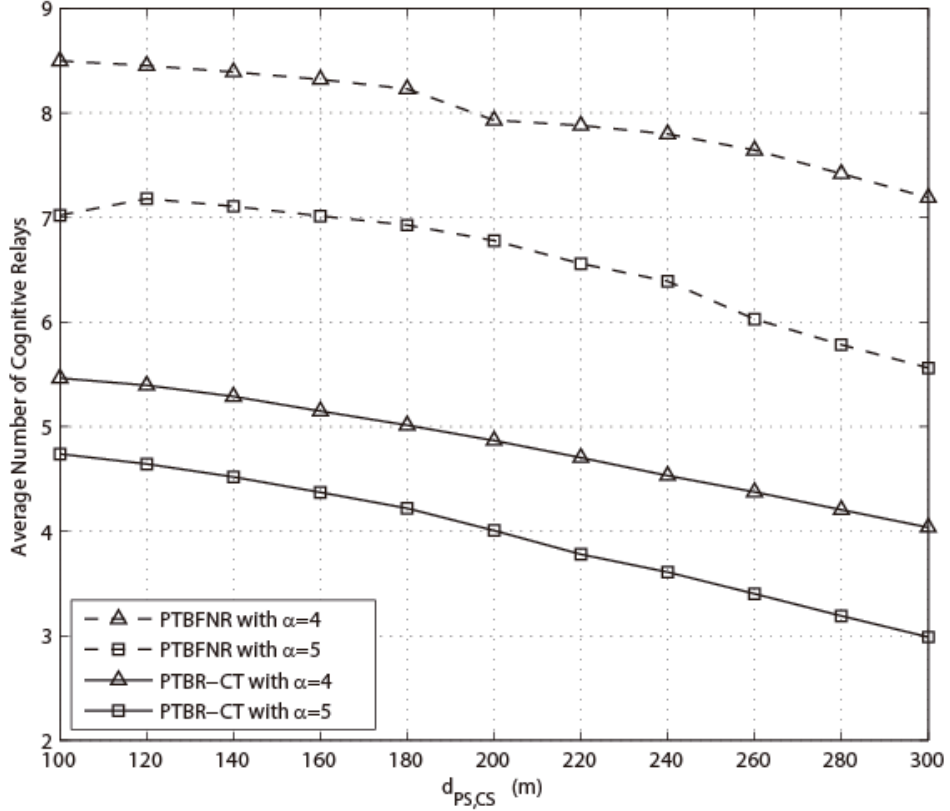

Figure 5.11: Average number of cognitive relays versus the distance between the PS and the CS for $p_{on} = 0.7$.

Figure 5.12 shows the average end-to-end reliability versus the probability that the PS is transmitting data to the PD. The end-to-end reliability is defined as the successful reception probability of a packet at all cognitive relays on the route and the CD. From Fig. 5.12, we can observe that PTBR-CT outperforms PTBFNR at $\alpha = 4$ and $\alpha = 5$ for $d_{PS,CS} = 200\text{m}$. The reason is that the number of cognitive relays on the route from the CS to the CD is reduced because of cooperative transmission.

Figure 5.13 and 5.14 show the average end-to-end throughput versus the probability that the PS is transmitting data to the PD and the distance between the PS and the CS, respectively. The end-to-end throughput [65], [80], can be written as

$$T = \min_{s=1,\dots,M+1} \frac{t_c^{(s)}}{M+1}, \quad (5.39)$$

where $t_c^{(s)}$ is the throughput measured at the s th cognitive relay, for $s = 1, \dots, M$,

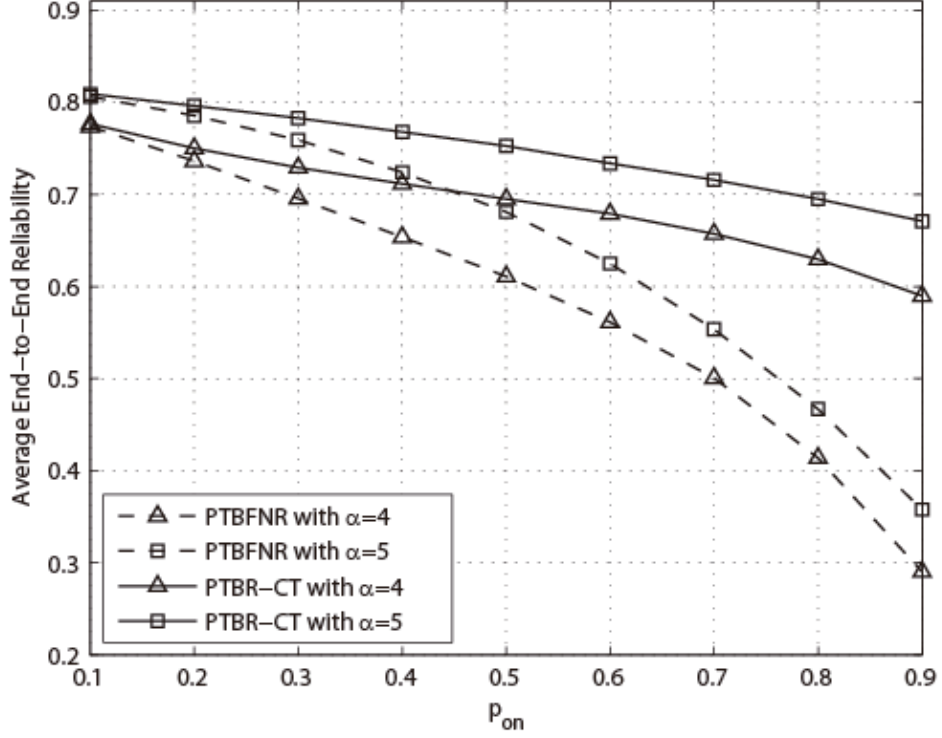

Figure 5.12: Average end-to-end reliability versus the probability that the PS is transmitting data to the PD for $d_{PS,CS} = 200\text{m}$.

and $t_c^{(M+1)}$ is the throughput measured at the CD. They are defined as

$$t_c^{(s)} = R^{(s)} \times \beta_c^{(s)}, \quad (5.40)$$

where $R^{(s)}$ is the transmission rate measured at the s th cognitive relay, for $s = 1, \dots, M$, $R^{(M+1)}$ denotes the spectral efficiency measured at the CD, $\beta_c^{(i)}$ represents the probability of successful reception of a packet at the i th cognitive relay, for $s = 1, \dots, M$, and $\beta_c^{(M+1)}$ denotes the probability of the successful reception of a packet at the CD. For calculating the end-to-end throughput of PTBR-CT in Fig. 5.13 and 5.14, after the multihop route is found, the throughput at each cognitive relay and the CD is first calculated. If the cognitive relay is a receiver of cognitive cooperative transmission interfered by the PS, the throughput equals to the multiplication of the spectral efficiency that can be calculated according to (5.32) and the successful packet reception probability that can be calculated according to (5.20).

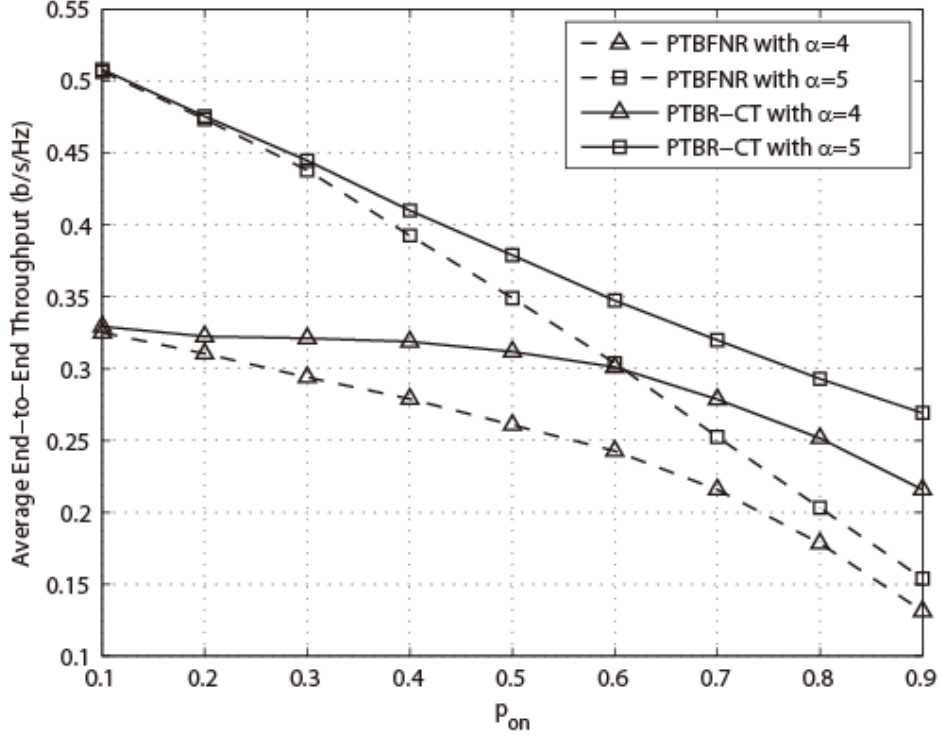

Figure 5.13: Average end-to-end throughput versus the probability that the PS is transmitting data to the PD for $d_{PS,CS} = 200\text{m}$.

Then, the minimum of the throughputs of all cognitive relays and the CD is found, and by dividing the minimum throughput by $M + 1$, we can obtain the end-to-end throughput. Normally, the end-to-end throughput equals to the minimum throughput of all cognitive relays and the CD. However, as described in Section 2.1, we do not consider the concurrency of the multihop relaying. In addition, cooperative transmission can be regarded as direct transmission because what we calculate is the throughput measured at the cognitive relay that receives data of cooperative transmission. Therefore, as shown in (5.39), to obtain the end-to-end throughput, it is necessary to divide the minimum throughput of all cognitive relays and the CD by $M + 1$. Finally, the average end-to-end throughput is calculated by averaging 10000 end-to-end throughputs. From Fig. 5.13 and 5.14, we can observe that compared to PTBFNR, the average end-to-end throughput is increased by PTBR-CT at $\alpha = 4$ and $\alpha = 5$ for $d_{PS,CS} = 200\text{m}$ and $p_{on} = 0.7$. This is because cooperative

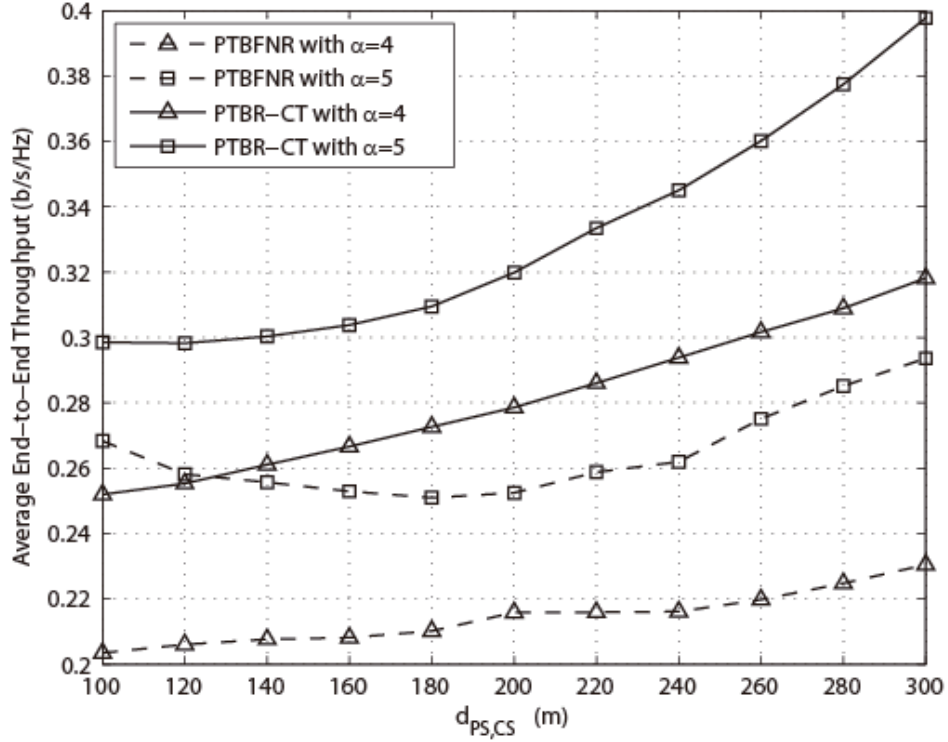

Figure 5.14: Average end-to-end throughput versus the distance between the PS and the CS for $p_{on} = 0.7$.

transmission reduces the number of cognitive relays on the route from the CS to the CD. The improvement is about 0.05 at $p_{on} = 0.5$ for $\alpha = 4$ and $d_{PS,CS} = 200\text{m}$. The importance of this improvement is described as follows. In [82], the authors propose and evaluate two distributed relaying schemes in multihop wireless networks. The proposed schemes consider the number of hops, the link states, and the successful probability of establishing a route between the source and the destination. From the simulation results shown in [82], we can observe that although the proposed scheme outperforms the best conventional one in terms of the average end-to-end throughput, the improvement is between about 0.06 b/s/Hz and about 0.09 b/s/Hz when the distance between the source and the destination is between 3.5Km and 5Km. Therefore, we can know that it is difficult to improve the average end-to-end throughput even if various factors that affect the end-to-end performance are

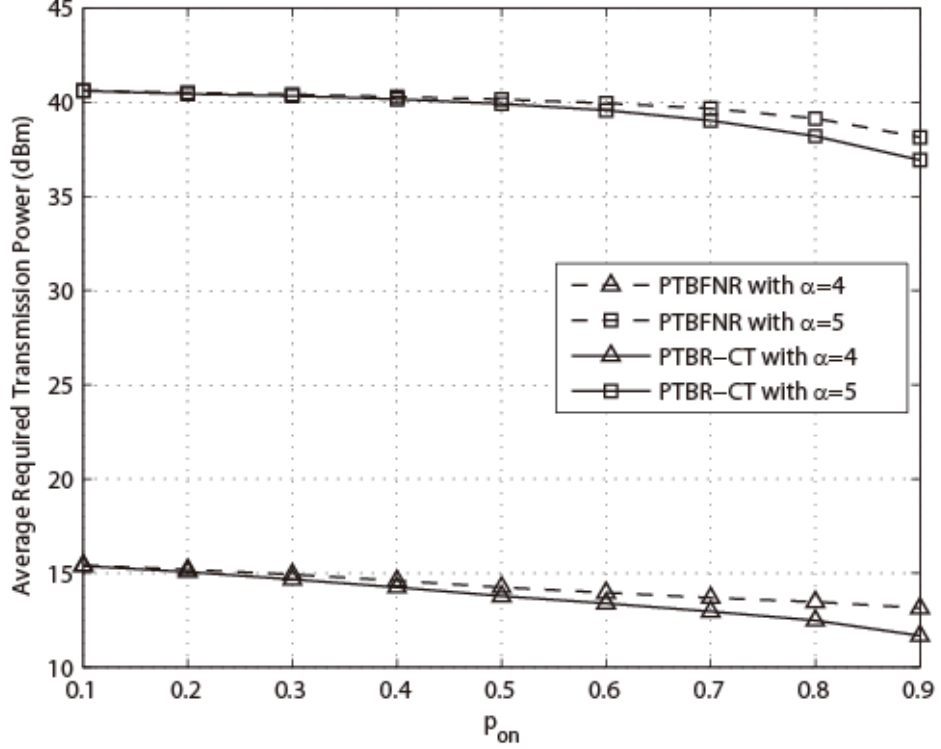

Figure 5.15: Average required transmission power versus the probability that the PS is transmitting data to the PD for $d_{PS,CS} = 200\text{m}$.

considered. This explains that the improvement of about 0.05 is important to the communication performance.

Figure 5.15 shows the average required transmission power of transmitting data from the CS to the CD versus the probability that the PS is transmitting data to the PD. The average required transmission power can be given by

$$P = P_{CS} + \sum_{i=1}^M P_{A_i} + \sum_{j=1}^N P_{B_j}, \quad (5.41)$$

where P_{CS} , P_{A_i} , and P_{B_j} are the required transmission power of the CS, the i th cognitive relay, and the j th cognitive partner, respectively. For calculating the required transmission power of transmitting data from the CS to the CD of PTBR-CT in Fig. 5.15, after the multihop route is found, the required transmission power of each cognitive direct transmission and each cognitive cooperative transmission is first calculated. If there is a cognitive partner assisting the cognitive relay that

sends data, the sum of the required transmission power of the cognitive relay that sends data and that of the cognitive partner can be calculated according to (5.33). Then, the required transmission power can be obtained by adding all the required transmission power of the cognitive direct and cooperative transmissions. Finally, by averaging 10000 required transmission power, we can obtain the average required transmission power. From Fig. 5.15, we can observe that the average required transmission power of PTBFNR with $\alpha = 4$ and $\alpha = 5$ decreases when p_{on} increases from 0.1 to 0.9. This phenomenon is explained as follows. When p_{on} increases, the shorter maximum transmission distance of the cognitive relay that sends data of the single hop transmission interfered by the PS will be used more times to select the cognitive relay that receives data. As a result, the total number of cognitive relays and the number of the cognitive relays that send data of the single hop cognitive transmission interfered by the PS increase. But, the number of cognitive relays that send data of the single hop interference-free transmission decrease. Therefore, the required transmission power of the OFF state of the primary traffic decreases, and that of the ON state increases. Figure 5.16 and 5.17 show the average required transmission power versus the probability that the PS is transmitting data to the PD with $\alpha = 4$ and $\alpha = 5$, respectively. From Fig. 5.16 and 5.17, we can observe that when p_{on} increases from 0.1 to 0.9, the decreasing amount of the average required transmission power of the OFF state of the primary traffic is larger than that of the ON state of the primary traffic. As a result, although the average number of cognitive relays on the route from the CS to the CD increases, the average required transmission power of transmitting data from the CS to the CD decreases. Figure 5.18 shows the average required transmission power of transmitting data from the CS to the CD versus the distance between the PS and the CS. The use of (5.33) to calculate the results of PTBMR-CT in Fig. 5.18 is same as that to calculate the results of PTBR-CT in Fig. 5.15. We explain the results shown in Fig. 5.18 as follows. When $d_{PS,CS}$ increases, the distances between each cognitive relay and the PD and between each cognitive partner and the PD increase. According to (5.9), (5.26), and (5.27), the transmission power of each cognitive relay and that

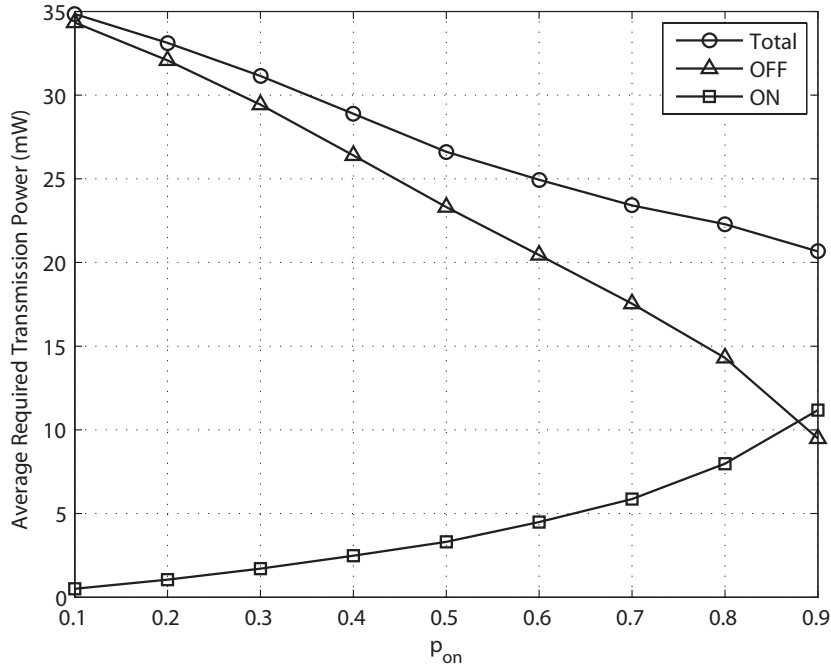

Figure 5.16: Average required transmission power versus the probability that the PS is transmitting data to the PD of the PTBFNR with $\alpha = 4$ for $d_{PS,CS} = 200\text{m}$.

of each cognitive partner increase when the distances between them and the PD increase, and other parameters remain the same. Therefore, when $d_{PS,CS}$ increases, each cognitive relay and each cognitive partner use larger power to transmit data. This causes that subject to the QoS requirement of the cognitive transmission, the single hop transmission distance becomes longer, and a cognitive relay that receives data and is with a larger x coordinate can be selected for cooperative transmission. Due to these two consequences, the number of cognitive relays and that of cognitive partners are reduced. Thus, although the transmission power of each cognitive relay and that of each cognitive partner increase, the transmission power of the end-to-end path cannot be always increased. Figure 5.15 and 5.18 show that PTBR-CT outperforms PTBFNR at $\alpha = 4$ and $\alpha = 5$ for $d_{PS,CS} = 200\text{m}$ and $p_{on} = 0.7$. This is because the number of cognitive relays on the route from the CS to the CD is reduced by cooperative transmission.

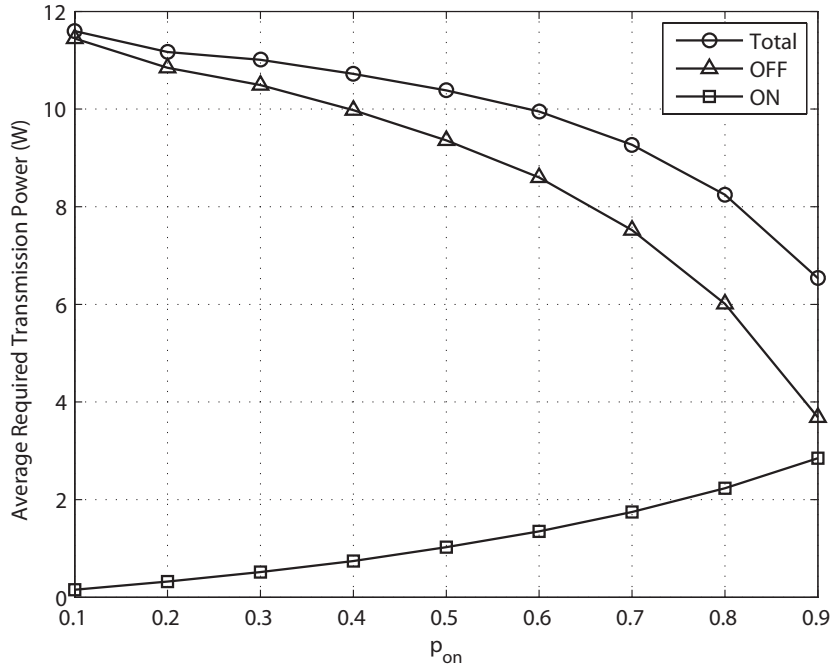

Figure 5.17: Average required transmission power versus the probability that the PS is transmitting data to the PD of the PTBFNR with $\alpha = 5$ for $d_{PS,CS} = 200\text{m}$.

Figure 5.19 and 5.20 show the average end-to-end transmission latency versus the probability that the PS is transmitting data to the PD and the distance between the PS and the CS, respectively. According to the IEEE 802.11a standard, the maximum length of the MAC data frame is 2346 bytes, and the transmission bandwidth is 20 MHz. By dividing the size of one data frame by the transmission rate, we can obtain the transmission time of one data frame. Based on the parameters of the IEEE 802.11a and our simulation, transmitting one MAC data frame with the maximum length requires 0.4692 ms. Fig. 5.19 and 5.20 show the results for transmitting one MAC data frame with the maximum length. Normally, the end-to-end transmission latency equals to the sum of the queuing latency, the transmission latency of the MAC data frame, and the propagation latency. However, in wireless sensor networks that is an important application of ad hoc networks, it is normally assumed that the data traffic load is light, and the data packet rate is low,

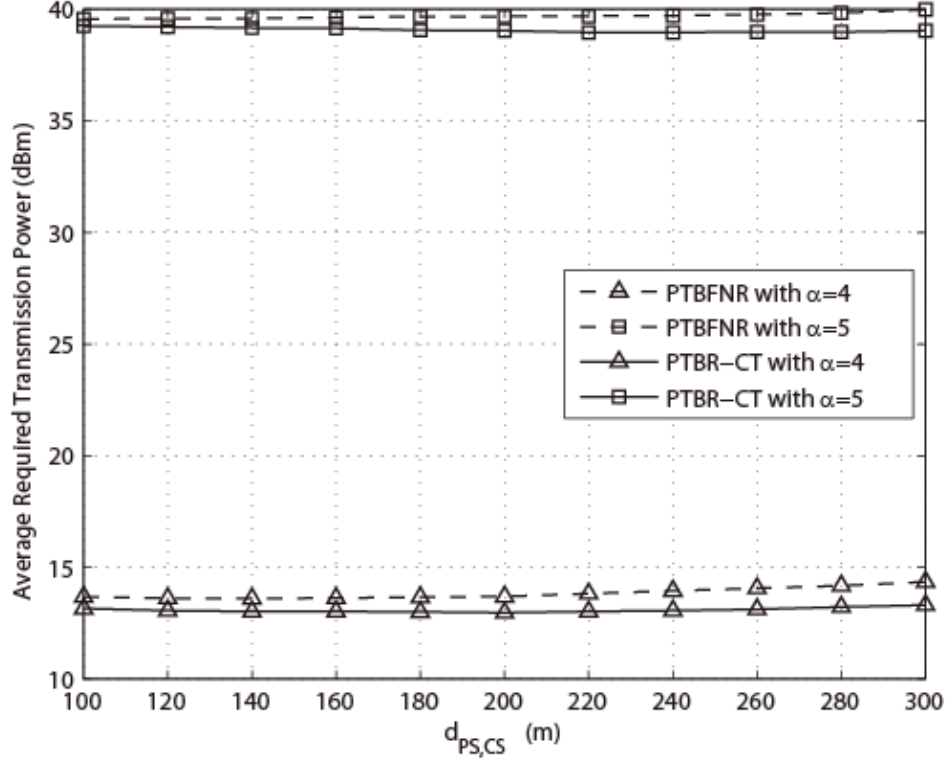

Figure 5.18: Average required transmission power versus the distance between the PS and the CS for $p_{on} = 0.7$.

and thus, the queuing latency can be ignored [83]. In addition, the propagation latency can also be ignored because compared to other considered latencies, it is relatively small. Consequently, we assume that the end-to-end transmission latency equals to the transmission time of transmitting one MAC data frame with the maximum length from the CS to the CD. From Fig. 5.19 and 5.20, we can conclude that PTBR-CT reduces the average end-to-end transmission latency compared to PTBFNR at $\alpha = 4$ and $\alpha = 5$ for $d_{PS,CS} = 200\text{m}$ and $p_{on} = 0.7$, although cooperative transmission prolongs the latency of transmitting the data from a cognitive relay that sends data to a cognitive relay that receives data. The reason is that the number of cognitive relays on the route from the CS to the CD is reduced due to the x coordinate enlargement brought by cooperative transmission.

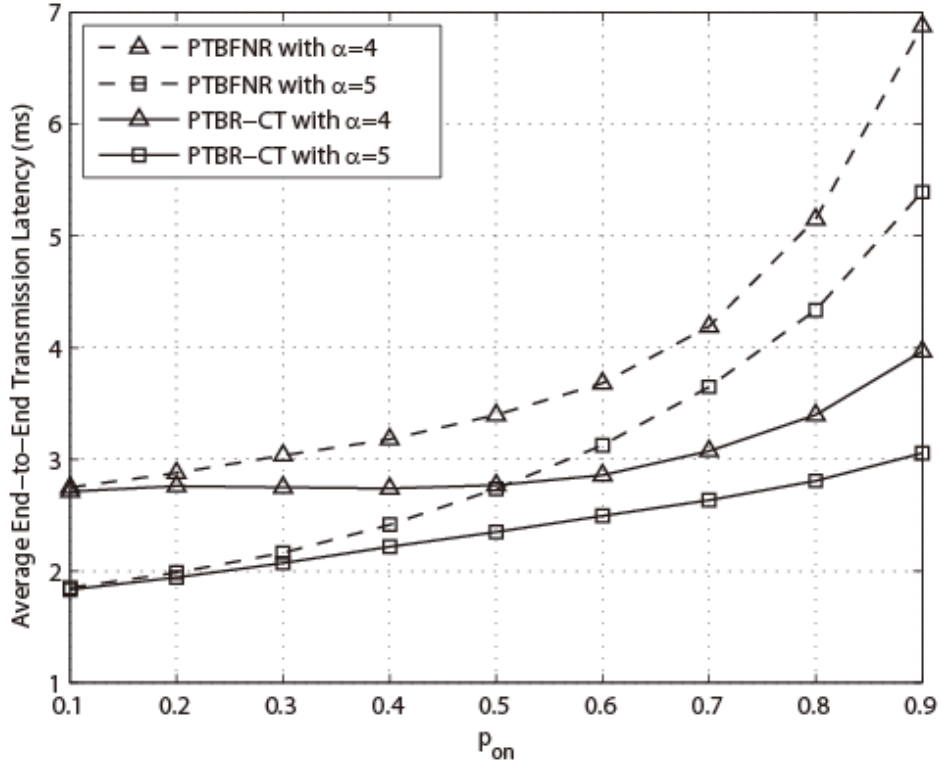

Figure 5.19: Average end-to-end transmission latency versus the probability that the PS is transmitting data to the PD for $d_{PS,CS} = 200\text{m}$.

5.10 Conclusion

We have proposed PTBR-CT that exploits cooperative transmission to reduce the number of cognitive relays when the primary and cognitive transmissions coexist successively in two hops. Simulation results show that compared to PTBFNR, PTBR-CT reduces the average number of cognitive relays and has better performance in terms of the average end-to-end reliability, the average end-to-end throughput, the average required transmission power of transmitting data from the CS to the CD, and the average end-to-end transmission latency.

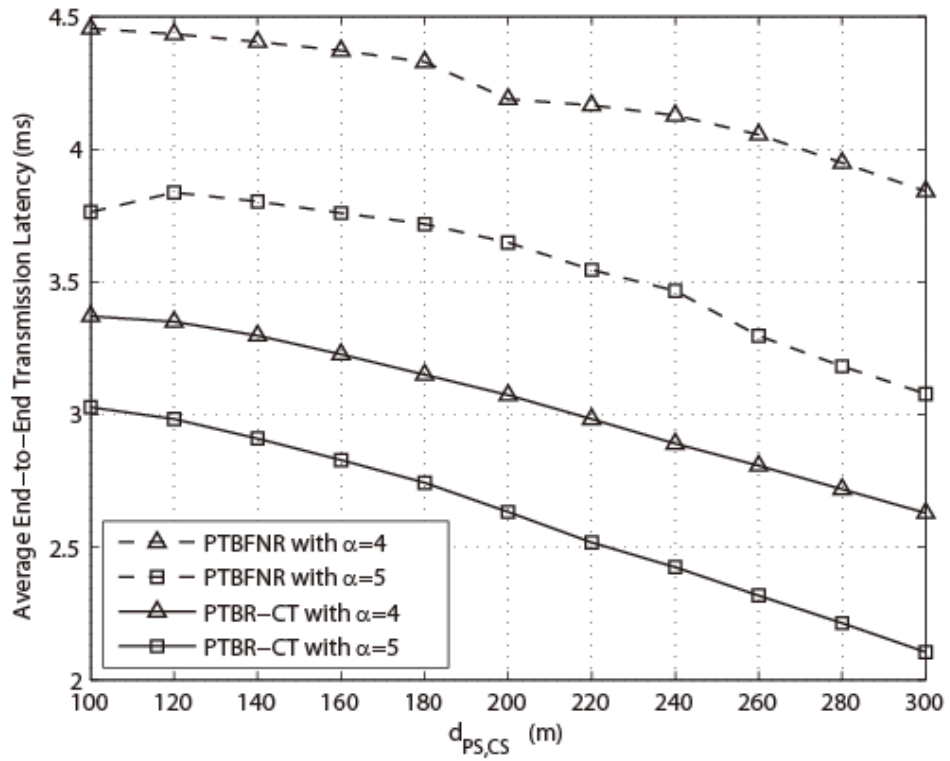

Figure 5.20: Average end-to-end transmission latency versus the distance between the PS and the CS for $p_{on} = 0.7$.

Chapter 6

Overall Conclusion

We have studied relay selection and routing for cooperative and cognitive radio ad hoc networks. For cooperative transmissions, we focused on the issue of hybrid relaying based schemes. In the literature, although several hybrid relaying schemes have been proposed to improve the system performance. They did not address the practical problems concerned to the implementation of the ideas. As a result, in Chapter 2, we proposed a practical IEEE 802.11 based approach to implement the hybrid relaying function and the semi-distributed relay selection in an ad hoc network where each relay candidate adaptively employs the amplify-and-forward (AF) or the decode-and-forward (DF) or the no relaying (direct transmission). We investigated the location distribution and the number of times that the AF, the DF, and the no relaying achieve the minimum theoretical bit error rate (BER). It is shown that the proposed scheme outperforms the AF, the DF relaying, and the direct transmission.

We also focused on the issue of single relay selection for cooperative transmissions. Although several practical relay selection schemes have been proposed, many problems of them still remain unsolved. In the conventional contention-based single relay selection, when the number of relay candidates is large, the transmission power of control packets becomes high. In addition, each relay candidate uses the same probability to contend for being selected as the relay without considering the channel gain of itself. Therefore, in Chapter 3, we proposed a medium access control (MAC) protocol that exploits group-based probabilistic contention and re-participation to implement distributed relay selection. Our aim is to select the relay with the minimum outage probability. Relay candidates with lower outage probabilities contend earlier, and in one contention slot, a higher probability is assigned to a relay candidate to contend. When a relay candidate does not contend in the

current contention slot, it is allowed to use a higher probability to contend in the next contention slot. The contention process is terminated once a relay candidate survives. Simulation results show that the proposed scheme outperforms the conventional one in terms of the outage probability, the number of contention slots, and the number of acknowledgement (ACK) packets.

For routing protocols in wireless ad hoc networks, we focused on cluster-based routing protocols that combines proactive and reactive characteristics. In cluster-based multihop networks, the energy minimized route can be discovered by searching all possible routes from the source to the destination. However, a central controller is required to collect the channel state information (CSI) of all links between any two nodes. Ad hoc routing (AHR) is shown to reduce the implementation complexity. However, due to the complexity reduction, the required transmission power increases. In addition, when the conventional distributed relay selection is used to implement AHR, the receiver selection error further increases the required transmission power. Thus, in Chapter 4, ad hoc cooperative routing (AHCR) and distributed ad hoc cooperative routing (DAHCR) schemes were proposed to exploit cooperative transmissions to reduce the required transmission power of AHR and distributed ad hoc routing (DAHR), respectively. In each hop of AHCR and DAHCR schemes, the nodes with the minimum and second minimum required sender transmission power are selected as the receiver and relay, respectively. In addition, in the DAHCR scheme, all qualified contention probabilities are re-distributed to increase the difference between any two qualified contention probabilities. Thus, the node with the highest contention probability will have more opportunity to be selected. Simulation results validates the effectiveness of the proposed routing schemes.

For cognitive radio networks, we focused on routing schemes with local spectrum knowledge. In cognitive radio ad hoc network (CRAHN) with the underlay access strategy, farthest neighbor routing (FNR) that selects the farthest neighbor as the receiver in each hop has been proposed to find a multihop route without considering the primary traffic pattern. When the primary traffic pattern is considered, the coexistence of the primary and secondary traffic shortens the transmission dis-

tance of the cognitive relay, and thus the number of cognitive relays on the multihop route is increased. The end-to-end reliability degrades due to the increased number of cognitive relays on the multihop route. To improve the end-to-end performance, in Chapter 5, we proposed a primary traffic based routing algorithm with cooperative transmission (PTBR-CT) that exploits cooperative transmissions to enlarge shorter transmission distances to reduce the number of cognitive relays on the multihop route. The successful reception probability of a packet is used as the routing metric. When the primary traffic occurs in the current time slot, a cognitive receiver for performing the cooperative transmission is selected preliminarily. The incremental relaying protocol is performed when the primary traffic occurs in the next time slot. The effectiveness of PTBR-CT is approved by simulation results.

Bibliography

- [1] C. M. Cordeiro and D. P. Agrawal, "Mobile ad hoc networking," in *Tutorial presented in the 20th Brazilian Symposium on Computer Networks*, pp. 125-186, May 2002.
- [2] C. E. Perkins, "Ad hoc networking," Addison-Wesley, 2001.
- [3] C. K. Toh, "Ad hoc mobile wireless networks: Protocols and systems," Prentice Hall, 2001.
- [4] I. F. Akyildiz, W. Su, Y. Sankarasubramaniam, and E. Cayirci, "Wireless sensor network: A survey," *Comput. Netw.*, vol. 38, no. 4, pp. 393-422, Mar. 2002.
- [5] N. Jain and D. P. Agrawal, "Current trends in wireless sensor network design," *International Journal of Distributed Sensor Networks*, vol. 1, no. 1, pp. 101-122, 2005.
- [6] S. Roundy, P. K. Wright, and J. Rabaey, "A study of low level vibrations as a power source for wireless sensor nodes," *Comput. Commun.*, vol. 26, no. 11, pp. 1131-1144, Jul. 2003.
- [7] S. Roundy, D. Steingart, L. Frechette, P. Wright, and J. Rabaey, "Power sources for wireless sensor networks," in *Proc. 1st European Workshop on Wireless Sensor Networks (EWSN)*, Jan. 2004.
- [8] J. Haarsten, "Bluetooth - the universal radio interface for ad hoc wireless connectivity," *Ericsson Review (3)*, 1998.
- [9] IEEE 802.15 Working Group for WPAN, <http://www.ieee802.org/15/>.
- [10] B. McQueen and J. McQueen, "Intelligent transportation systems architectures," Artech House, 1999.
- [11] B. McQueen, R. Schuman, K. Chen, "Advanced traveler information systems," Artech House, 2002.
- [12] D. M. Blough and P. Santi, "Investigating upper bounds on network lifetime extension for cell-based energy conservation techniques in stationary ad hoc networks," in *Proc. 8th Annual International Conference on Mobile Computing and Networking (MobiCom)*, pp. 183-192, Sep. 2002.

- [13] Richard Bellman, "On a routing problem," *Quarterly of Applied Mathematics* 16, pp. 87-90, 1958.
- [14] E. W. Dijkstra, "A note on two problems in connexion with graphs," *Numerische Mathematik* 1, pp. 269-271, 1959.
- [15] K. R. Chowdhury and M. D. Felice, "Search: A routing protocol for mobile cognitive radio ad-hoc networks," *Comput. Commun.*, vol. 32, no. 18, pp. 1983-1997, Dec. 2009.
- [16] C. E. Perkins and P. Bhagwat, "Highly dynamic destination-sequenced distance-vector routing (DSDV) for mobile computers," in *Proc. SIGCOMM'94 Conference on Communications Architecture, Protocols, and Applications*, pp. 234-244, Aug. 1994.
- [17] S. Murthy and J. J. Garcia-Luna-Aceves, "An efficient routing protocol for wireless networks," *ACM Mobile Networks and Applications Journal*, vol. 1, no. 2, pp. 183-197, Oct. 1996.
- [18] D. B. Johnson and D. A. Maltz, "Dynamic source routing in ad hoc wireless networks," *Mobile Computing*, Kulwer Academic, vol. 353, pp. 153-181, 1996.
- [19] C. E. Perkins and E. M. Royer, "Ad-hoc on-demand distance vector routing," in *Proc. 2nd IEEE Workshop on Mobile Computing Systems and Applications*, pp. 90-100, Feb. 1999.
- [20] Z. J. Haas and M. R. Pearlman, "The zone routing protocol (ZRP) for ad hoc networks," in *IETF MANET Draft*, Jun. 1999.
- [21] Z. J. Haas and M. R. Pearlman, "The performance of query control schemes for the zone routing protocol," *IEEE/ACM Trans. Netw.*, vol. 9, no. 4, pp. 427-438, Aug. 2001.
- [22] B. Gui, L. Dai, and L. J. Cimini, "Routing strategies in multihop cooperative networks," in *IEEE Trans. Wireless Commun.*, vol. 8, no. 2, pp. 843-855, Feb. 2009.
- [23] A. Scaglione, D. Goeckel, and J. Laneman, "Cooperative communication mobile ad hoc networks: rethinking the link abstraction," in *IEEE Sig. Proc. Magazine*, pp. 18-29, Sep. 2006.
- [24] H. Takagi and L. Kleinrock, "Optimal transmission ranges for randomly distributed packet radio terminals," *IEEE Trans. Commun.*, vol. 32, no. 3, pp. 246-257, Mar. 1984.

- [25] C. Liu and J. Wu, "Destination-region-based local minimum aware geometric routing," in *IEEE International Conference on Mobile Adhoc and Sensor Systems*, pp. 1-9, Oct. 2007.
- [26] E. C. van der Meulen, "Three-terminal communication channels," *Adv. Appl. Prob.*, vol. 3, pp. 120-154, 1971.
- [27] T. Cover and A. El Gamal, "Capacity theorems for the relay channel," *IEEE Trans. Inform. Theory*, vol. 25, no. 5, Sep. 1979.
- [28] A. Sendonaris, E. Erkip, and B. Aazhang, "User cooperation diversity-Part I: System description," *IEEE Trans. Commun.*, vol. 51, no. 11, pp. 1927-1938, Nov. 2003.
- [29] A. Sendonaris, E. Erkip, and B. Aazhang, "User cooperation diversity-Part II: Implementation aspects and performance analysis," *IEEE Trans. Commun.*, vol. 51, no. 11, pp. 1939-1948, Nov. 2003.
- [30] J. N. Laneman, D. N. C. Tse, and G. W. Wornell, "Cooperative diversity in wireless networks: Efficient protocols and outage behavior," *IEEE Trans. Inform. Theory*, vol. 50, no. 12, pp. 3062-3080, Dec. 2004.
- [31] M. Vajapeyam and U. Mitra, "A hybrid space-time coding scheme for cooperative networks," in *Proc. 42'nd Allerton Conference on Communications, Control and Computing, University of Illinois Press*, Oct. 2004.
- [32] J. Adeane, M. R. D. Rodrigues, and I. J. Wassell, "Optimum power allocation in cooperative networks," in *Proc. 12th International Conference on Telecommunications.*, May, 2005.
- [33] V. Mahinthan, J. W. Mark, and X. S. Shen, "Adaptive regenerate and forward cooperative diversity system based on quadrature signaling," in *Proc. IEEE Global Communications Conference*, pp. 1-5, Nov. 2006.
- [34] B. Can, H. Yomo, and E. D. Carvalho, "Hybrid forwarding scheme for cooperative relaying in OFDM based networks," in *Proc. IEEE International Conference on Communications*, vol. 10, pp. 4520-4525, Jun. 2006.
- [35] Y. Li, B. Vucetic, Z. Chen, and J. Yuan, "An improved relay selection scheme with hybrid relaying protocols," in *Proc. IEEE Global Communications Conference*, pp. 3704-3708, Nov. 2007.

- [36] J. N. Laneman and G. W. Wornell, "Distributed space-time-coded protocols for exploiting cooperative diversity in wireless networks," *IEEE Trans. Inform. Theory*, vol. 49, no. 10, pp. 2415-2425, Oct. 2003.
- [37] A. Bletsas, A. Khitsi, D. P. Reed, and A. Lippman, "A simple cooperative diversity method based on network path selection," *IEEE J. Select. Areas Commun.*, vol. 24, no. 3, pp. 659-672, Mar. 2006.
- [38] V. Sreng, H. Yanikomeroglu, and D. D. Falconer, "Relayer selection strategies in cellular networks with peer-to-peer relaying," in *Proc. IEEE Vehicular Technology Conference*, pp. 1949-1953, Oct. 2003.
- [39] A. Ribeiro, X. Cai, and G. B. Giannakis, "Symbol error probabilities for general cooperative links," *IEEE Trans. Wireless Commun.*, vol. 4, no. 3, pp. 1264-1273, May 2005.
- [40] A. K. Sadek, Z. Han, and K. J. R. Liu, "Distributed relay-assignment protocols for coverage expansion in cooperative wireless networks," *IEEE Trans. Mob. Comput.*, vol. 9, no. 4, pp. 505-515, Apr. 2010.
- [41] Y. Zhao, R. Adve, and T. J. Lim, "Improving amplify-and-forward relay networks: optimal power allocation versus selection," *IEEE Trans. Wireless Commun.*, vol. 6, no. 8, pp. 3114-3123, Aug. 2007.
- [42] B. Zhao and M. C. Valenti, "Practical relay networks: a generalization of hybrid-ARQ," in *IEEE J. Select. Areas Commun.*, vol. 23, no. 1, pp. 7-18, Jan. 2005.
- [43] H. Shan, P. Wang, W. Zhuang, and Z. Wang, "Cross-layer cooperative triple busy tone multiple access for wireless networks," in *Proc. IEEE Global Telecommunications Conference*, pp. 1-5, Nov. 2008.
- [44] C. K. Lo, R. W. Heath, and S. Vishwanath, "The impact of channel feedback on opportunistic relay selection for hybrid-ARQ in wireless networks," in *IEEE Trans. Veh. Technol.*, vol. 58, no. 3, pp. 1255-1268, Mar. 2009.
- [45] A. E. Khandani, J. Abounadi, E. Modiano, and L. Zheng, "Cooperative routing in static wireless networks," in *Proc. 41st Annual Allerton Conference on Communication, Control, and Computing*, pp. 2170-2179, Oct. 2003.
- [46] F. Li, K. Wu, and A. Lippman, "Energy-efficient cooperative routing in multi-hop wireless ad hoc networks," in *Proc. IEEE International Performance, Computing, and Communications Conference*, pp. 215-222, Apr. 2006.

- [47] Z. Yang and A. Host-Madsen, "Routing and power allocation in asynchronous Gaussian multiple-relay channels," *EURASIP J. Wireless Commun. and Networking*, pp. 1-11, 2006.
- [48] J. Luo, R. S. Blum, L. J. Greenstein, L. J. Cimini, and A. M. Haimovich, "New approaches for cooperative use of multiple antennas in ad hoc wireless networks," in *Proc. IEEE 60th Vehicular Technology Conference*, vol. 4, pp. 2769-2773, Sep. 2004.
- [49] C. Pandana, W. P. Siriwongpairat, T. Himsoon, and K. J. R. Liu, "Distributed cooperative routing algorithms for maximizing network lifetime," in *Proc. IEEE Wireless Communications and Networking Conference*, vol. 1, pp. 451-456, Apr. 2006.
- [50] L. Ong and M. Motani, "Optimal routing for decode-and-forward based cooperation in wireless networks," in *Proc. 4th Annual IEEE Communications Society Conference on Sensor, Mesh and Ad Hoc Communications and Networks*, pp. 334-343, Jun. 2007.
- [51] S. Savazzi and U. Spagnolini, "Energy aware power allocation strategies for multihop-cooperative transmission schemes," *IEEE J. Select. Areas Commun.*, vol. 25, no. 2, pp. 318-327, Feb. 2007.
- [52] J. Mitola III, "Cognitive radio: An integrated agent architecture for software defined radio." PhD thesis, Royal Institute of Technology (KTH), Stockholm, Sweden, May 2000.
- [53] J. Mitola and G. Q. Maguire, "Cognitive radio: Making software radios more personal," *IEEE Pers. Commun.*, vol. 6, no. 4, pp. 13-18, Aug. 1999.
- [54] M. G. Khoshkholgh, K. Navaie, and H. Yanikomeroglu, "Access strategies for spectrum sharing in fading environment: overlay, underlay, and mixed," *IEEE Trans. Mob. Comput.*, vol. 9, no. 12, pp. 1780-1793, Dec. 2010.
- [55] Y.-C. Liang, K.-C. Chen, G. Y. Li, and P. Mahonen, "Cognitive radio networking and communications: An overview," *IEEE Trans. Veh. Technol.*, vol. 60, no. 7, pp. 3386-3407, Sep. 2011.
- [56] FCC, FCC 08-260, Unlicensed Operation in the TV Broadcast Bands, Nov. 2008.
- [57] C. Xin, B. Xie, and C.-C. Shen, "A novel layered graph model for topology formation and routing in dynamic spectrum access networks," in *Proc. First*

IEEE International Symposium on New Frontiers in Dynamic Spectrum Access Networks, pp. 308-317, Nov. 2005.

- [58] C. Xin, L. Ma, and C.-C. Shen, "A path-centric channel assignment framework for cognitive radio wireless networks," *Mob. Netw. and Appl.*, vol. 13, no. 5, pp. 463-476, 2008.
- [59] X. Zhou, L. Lin, J. Wang, and X. Zhang, "Cross-layer routing design in cognitive radio networks by colored multigraph model," *Wireless Pers. Commun.*, vol. 49, no. 1, pp. 123-131, 2009.
- [60] Q. Wang and H. Zheng, "Route and spectrum selection in dynamic spectrum networks," in *Proc. 3rd IEEE Consumer Communications and Networking Conference*, vol. 1, pp. 625-629, Jan. 2006.
- [61] Y. Hou, Y. Shi, and H. Sherali, "Optimal spectrum sharing for multi-hop software defined radio networks," in *Proc. 26th IEEE International Conference on Computer Communications*, pp. 1-9, May 2007.
- [62] Y. Hou, Y. Shi, and H. Sherali, "Spectrum sharing for multi-hop networking with cognitive radios," *IEEE J. Select. Areas Commun.*, vol. 26, no. 1, pp. 146-155, Jan. 2008.
- [63] C. W. Pyo and M. Hasegawa, "Minimum weight routing based on a common link control radio for cognitive wireless ad hoc networks," in *Proc. International Conference in Wireless Communications and Mobile Computing*, pp. 399-404, Aug. 2007.
- [64] Y. Shi and Y. Hou, "A distributed optimization algorithm for multi-hop cognitive radio networks," in *Proc. 27th IEEE Conference on Computer Communications*, pp. 1292-1300, Apr. 2008.
- [65] M. Xie, W. Zhang, and K.-K. Wong, "A geometric approach to improve spectrum efficiency for cognitive relay networks," *IEEE Trans. Wireless Commun.*, vol. 9, no. 1, pp. 268-281, Jan. 2010.
- [66] H. Ma, L. Zheng, X. Ma, and Y. Iuo, "Spectrum aware routing for multi-hop cognitive radio networks with a single transceiver," in *Proc. 3rd International Conference on Cognitive Radio Oriented Wireless Networks and Communications*, pp. 1-6, May 2008.
- [67] G. Cheng, W. Liu, Y. Li, and W. Cheng, "Spectrum aware on-demand routing in cognitive radio networks," in *Proc. 2nd IEEE International Symposium on New Frontiers in Dynamic Spectrum Access Networks*, pp. 571-574, Apr. 2007.

- [68] G. Cheng, W. Liu, Y. Li, and W. Cheng, "Joint on-demand routing and spectrum assignment in cognitive radio networks," in *Proc. IEEE International Conference on Communications*, pp. 6499-6503, Jun. 2007.
- [69] Z. Yang, G. Cheng, W. Liu, W. Yuan, and W. Cheng, "Local coordination based routing and spectrum assignment in multi-hop cognitive radio networks," *Mob. Netw. and Appl.*, vol. 13, no. 1-2, pp. 67-81, 2008.
- [70] I. Pefkianakis, S. Wong, and S. Lu, "SAMER: spectrum aware mesh routing in cognitive radio networks," in *Proc. 3rd IEEE Symposium on New Frontiers in Dynamics Spectrum Access Networks*, pp. 1-5, Oct. 2008.
- [71] L. Ding, T. Melodia, S. Batalama, and M. J. Medley, "Rosa: distributed joint routing and dynamic spectrum allocation in cognitive radio ad hoc networks," in *Proc. 12th ACM International Conference on Modeling, Analysis and Simulation of Wireless and Mobile Systems*, pp.13-20, Oct. 2009.
- [72] A. Sampath, L. Yang, L. Cao, H. Zheng, and B. Y. Zhao, "High throughput spectrum-aware routing for cognitive radio based ad-hoc networks," in *Proc. 3rd International Conference on Cognitive Radio Oriented Wireless Networks and Communications*, May 2008.
- [73] G.-M. Zhu, I. Akyildiz, and G.-S. Kuo, "STOD-RP: a spectrum-tree based on-demand routing protocol for multi-hop cognitive radio networks," in *Proc. Global Telecommunications Conference*, pp. 1-5, Nov. 2008.
- [74] W. Feng, J. Cao, C. Zhang, and C. Liu, "Joint optimization of spectrum handoff scheduling and routing in multi-hop multi-radio cognitive networks," in *Proc. 29th IEEE International Conference on Distributed Computing Systems*, pp. 85-92, Jun. 2009.
- [75] A. Abbagnale, F. Cuomo, "Gymkhana: a connectivity-based routing scheme for cognitive radio ad hoc networks," in *Proc. IEEE Conference on Computer Communications*, pp. 1-5, Mar. 2010.
- [76] I. Filippini, E. Ekici, and M. Cesana, "Minimum maintenance cost routing in cognitive radio networks," in *Proc. IEEE 6th International Conference on Mobile Adhoc and Sensor Systems*, pp. 284-293, Oct. 2009.
- [77] H. Khalife, S. Ahuja, N. Malouch, and M. Krunz, "Probabilistic path selection in opportunistic cognitive radio networks," in *Proc. Global Telecommunications Conference*, pp. 1-5, Nov. 2008.

- [78] Z. Ji, Y. Yang, J. Zhou, M. Takai, and R. Bagrodia, "Exploiting medium access diversity in rate adaptive wireless LANs," in *Proceedings of the 10th Annual International Conference on Mobile Computing and Networking*, pp. 345-359, Sep. 2004.
- [79] M. Haenggi, "On routing in random Rayleigh fading networks," *IEEE Trans. Wireless Commun.*, vol. 4, no. 4, pp. 1553-1562, Jul. 2005.
- [80] A. S. Ibrahim, Z. Han, and K. J. R. Liu, "Distributed energy-efficient cooperative routing in wireless networks," *IEEE Trans. Wireless Commun.*, vol. 7, no. 10, pp. 1-12, Oct. 2008.
- [81] A. Nosratinia and T. E. Hunter, "Grouping and partner selection in cooperative wireless networks," *IEEE J. Select. Areas Commun.*, vol. 25, no. 2, pp. 369-378, Feb. 2007.
- [82] W. Wang, J. Cai, and A. S. Alfa, "Distributed routing schemes with accessibility consideration in multi-hop wireless networks," *IEEE Trans. Wireless Commun.*, vol. 9, no. 10, pp. 3178-3188, Oct. 2010.
- [83] M. Chen, W. Cai, S. Gonzalez, and V. Leung, "Balanced itinerary planning for multiple mobile agents in wireless sensor networks," in *Proc. 2nd International ICST Conference on Ad Hoc Networks (ADHOCNETS)*, Victoria, British Columbia, Canada, Aug. 2010.