

Damage Monitoring of Cracked Beams Based on Nonlinear Wave Modulation

ARATA MASUDA, YUICHIRO YONEMURA AND AKIRA SONE

ABSTRACT:

In this paper, a sensing methodology is developed and experimentally investigated to detect and characterize damages, which are essentially accompanied by changes in the micro/macroscale condition of surface contact. The proposed technique is developed mainly focusing on early detection of cracks in a beam structure, but also may be applicable to kissing bonds in adhesive joints as well as partial loss of preload in bolted joints under the operational condition. The presented system consists of PZT patches attached on the structural surface, one of which acts as a transmitter of high frequency harmonic wave. The incident harmonic wave is scattered by the contact surfaces which potentially involve damages, and received by the other patches. When the structure is subjected to the operational or ambient load at low frequencies, it vibrates, and the inherent damages may introduce a nonlinear effect to the vibro-acoustic dynamics that induces an interaction between the low frequency structural vibration and the high frequency transmitted wave. This nonlinearity is observed as the amplitude and phase modulation of the received wave due to the changes in the scattering characteristics synchronous with the structural vibration. By investigating the relationship between the modulations and the structural vibration, the nonlinear characteristics of the damages could be specified. In this paper, experiments using a beam with low-cycle fatigue cracks are conducted for the purpose of preliminary study.

INTRODUCTION

Nonlinear wave modulation (NWM) is a nonlinear coupling effect between low frequency vibration and ultrasonic acoustic wave at a rough contact surfaces where the contact condition may significantly influenced by the load acting on the interface, so that the scattering characteristics of the ultrasonic wave across the interface may change synchronously with the low frequency structural vibration. This phenomenon is employed in so-called nonlinear wave modulation spectroscopy (NWMS) [1-3], which is a nondestructive technique to detect early damages such as cracks very sensitively. This technique uses high frequency probe waves in the same manner as the conventional ultrasonic testing, but also low frequency excitation simultaneously, which is frequently termed “pump” excitation. Because of the NWM, the received probe wave is modulated in amplitude and phase. Experimental evidences have demonstrated that this modulation is

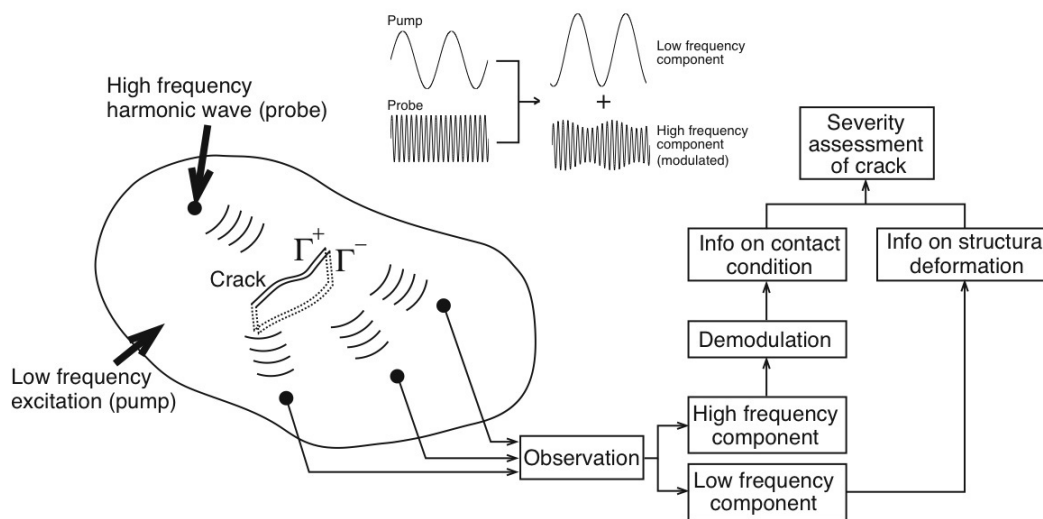

Figure 1 Conceptual drawing of the proposed crack monitoring system

very sensitive to the presence of damage [1]. Zaitsev and Sas [4] have discussed the mechanism of such significant effects observed even in a sample with a small crack, and proposed theoretical crack model considering thermoelastic dissipation at the contacting crack edges. Although the NWMS techniques usually use a continuous small-amplitude harmonic wave as the probe and a continuous large-amplitude harmonic vibration as the pump, other combination could be used to add new functions or to improve the performance of the technique. For example, Van Den Abeele et al. [1] have applied impact force as the pump excitation that may ease the in-field inspection. Kazakov and Johnson [5] have adopted a series of tonebursts as the probe wave to obtain an nonlinear image which indicates the location of the crack.

Masuda et al. [6] have proposed a NWM-based approach to the integrity monitoring of bolted joints. Experiments for a sample bolted beam has been conducted for illustrative purpose, in which two PZT patches are used as the transducer of high frequency probe wave. The collected signal at the receiver PZT patch is separated into low frequency and high frequency components, the former is used to obtain the information relevant to the structural vibration, while the latter is demodulated in amplitude and phase, in order to obtain the nonlinear relationship between the structural deformation and the observed modulation. A damage index has been defined based on the amplitude modulation and its high sensitivity to the joint imperfection has been demonstrated.

In this paper, the applicability of this concept to the crack monitoring problem is experimentally investigated. An apparatus of low-cycle fatigue testing is used for this purpose in which a specimen beam with an artificial notch is subjected to dynamic bending load that initializes and elongates fatigue cracks. The results indicate that the presence of fatigue cracks yields amplitude and phase modulation in the received probe waves.

NONLINEAR WAVE MODULATION INDUCED BY THE DEVELOPMENT OF BREATHING CRACKS

A conceptual drawing of the proposed crack monitoring system is shown in Fig. 1. The crack is expressed as intimately contacted surfaces Γ^+ and Γ^- . The system has several number of transducers attached on the body surface. One of them acts as a transmitter of small amplitude, high frequency harmonic wave (probe), and the rest act as receivers. The transmitter and the receivers can be placed on opposite sides of the crack, or all on the same side. Besides, the system is assumed to have another input, i.e., large amplitude, low frequency excitation force (pump). This can be harmonic, impact, or random force, provided either artificially (active excitation, operational load) or naturally (natural disturbance). In this paper, we assume harmonic excitation.

When subjected to the pump excitation, because the motion on Γ^+ and Γ^- may not be identical, localized relative motions both in-plane (microslip) and out-of-plane (microslap/gapping) are allowed under the loading force. The occurrence of these microscale motions can drastically change the microscale contact pressure distribution and the other contact conditions, and consequently, can affect the scatter characteristics of the interface for the high frequency probe wave. Therefore, the two inputs (probe and pump) interact on the interface, and the transfer function for the probe wave becomes time-varying and synchronous with the deformation induced by the pump excitation. Then, the output signal is represented as

$$y(t) = x_{pump}(t) + \beta(\omega, \delta) \left\{ + f(\omega, \delta, x_{pump}^c(t)) \right\} A \cos \left\{ \omega t + \varphi(\omega, \delta) + g(\omega, \delta, x_{pump}^c(t)) \right\} \quad (1)$$

where $y(t)$ is the acquired signal at the receiver PZT, $x_{pump}(t)$ and $x_{pump}^c(t)$ are the pump-induced vibration at the receiver PZT and at the crack location, respectively, and A and ω are the amplitude and the frequency of the probe wave. $f(\omega, \delta, x_{pump}^c(t))$ and $g(\omega, \delta, x_{pump}^c(t))$ are nonlinear modulation functions which define the amplitude and the phase modulation with respect to the deformation at the crack location and the damage extent δ . Equation (1) implies that the pump excitation causes the amplitude and the phase modulation of the probe wave. The first and the second term in R.H.S are obtained by splitting the observed signal into the low frequency component and the high frequency component. It is important to comprehend the characteristics of the modulation functions $f(\omega, \delta, x_{pump}^c(t))$ and $g(\omega, \delta, x_{pump}^c(t))$ to obtain the better understanding of NWM phenomena induced by the crack development.

EXPERIMENTAL SETUP AND PROCEDURE

Fatigue Test for Preparation of Specimens

Low-cycle fatigue tests were conducted using an apparatus shown in Fig. 2 (a) to develop test specimens with a fatigue crack. The specimen was a steel (SS400) beam with the thick of 6 mm, the width of 44 mm and the length of 550 mm with an artificial notch with the width of 1 mm and the depth of 3 mm, which was machined at 170 mm from the bottom. The specimen was installed in a test structure on the shaking table, which is made of a top slab supported by four thin plate columns and a base plate as shown in Fig. 2 (b). The bottom end of the specimen was bolted to a fixture on the base plate, and the top end was

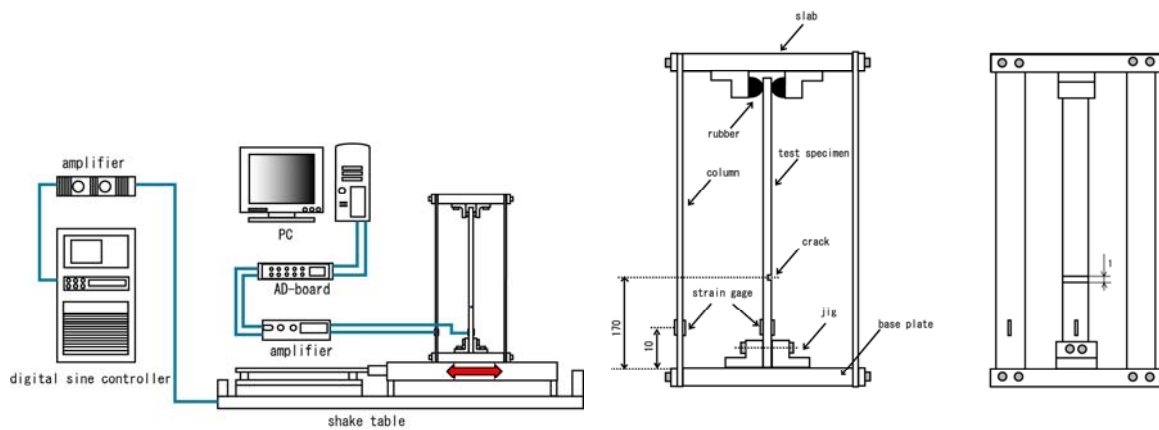

(a) Overview of the experimental setup for fatigue tests

(b) Test structure with a specimen

Figure 2 Schematics of experimental setup for fatigue tests

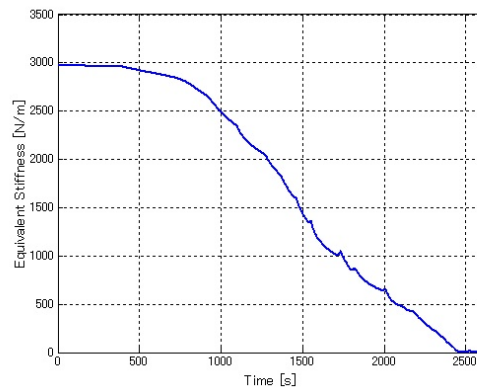

Figure 3 Change of equivalent stiffness of the specimen

supported by a pair of rubber semicircular cylinder fixed on the top slab. When the whole structure was subjected to a sinusoidal excitation near the natural frequency, the horizontal motion of the slab gave a large amplitude, periodic shear force at the top of the specimen, that produced a fatigue crack growing from the bottom of the notch. The sequence of the excitation frequency was designed to keep the resonance condition, following the change of the natural frequency of the structure, to break the specimen after 46 minutes, 11000 cycles, approximately.

The test structure had strain gauges on the column plates and on the bottom end of the specimen to measure the displacement of the top slab and the shear force acting on the top end of the specimen, respectively. Then, the equivalent stiffness was calculated from the force-displacement diagram to monitor the remaining stiffness of the specimen. Figure 3 shows the change of the equivalent stiffness of the specimen during the test.

Crack Monitoring Test

For a NWM-based crack monitoring test, the specimen with the crack was removed from the test structure, and then mounted on the shaking table as illustrated in Fig. 4 (a). Two PZT patches were bonded on the specimen with epoxy adhesive on the location shown

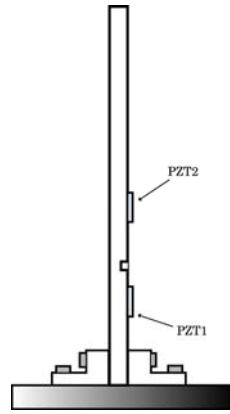

(a) Overview of the experimental setup for damage detection

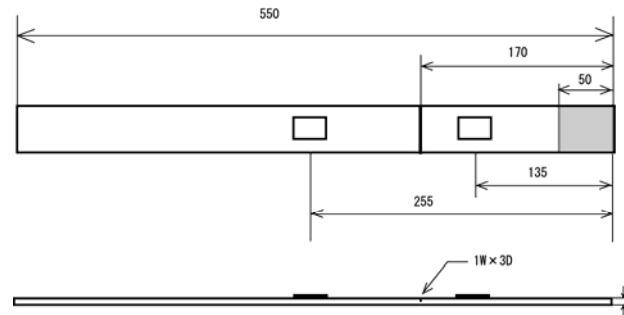

(b) Specimen with PZT patches

Figure 4 Experimental setup for crack detection test

in Fig. 4 (b). One near the bottom end, PZT 1, was used as a probe transmitter being excited by a 20 kHz, 30 Vp-p sinusoidal wave, while the other one, PZT 2, as a receiver of the probe wave transmitted across the crack. At the same time, the shaker was driven by a 10 Hz sinusoidal wave to provide a harmonic pumping. The amplitude of the harmonic pump was controlled so that the horizontal acceleration at the tip of the specimen was held constant (1.96 m/s², 3.92 m/s² and 5.88 m/s²) even when the stiffness of the specimen decreased due to the development of the crack. The received signal at PZT 2 was amplified and acquired by DAQ system with the sampling frequency of 500 kHz. All the data collected were processed using MATLAB.

Test Sequence

The whole test was conducted as follows. First, a healthy specimen was inspected by the crack monitoring test as described above. Then the specimen was set in the fatigue test structure and underwent the fatigue test, which was interrupted when the loss of the equivalent stiffness came up to 10 %. The specimen was taken out from the structure, then again, undergo the crack monitoring test. Similarly, the crack monitoring tests were conducted when the specimen experienced the stiffness loss of 30 % and 50 %.

The fatigue damage was evaluated by the following damage index as used in the previous paper [6] on the integrity monitoring of bolted joints:

$$DI = \frac{B_{\max} - B_{\min}}{B_{\max} + B_{\min}} \times 100 \quad (\%) \quad (2)$$

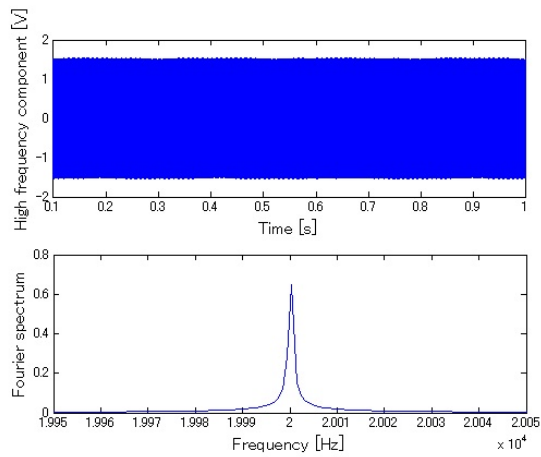

(a) 0% reduction in equivalent stiffness (healthy)

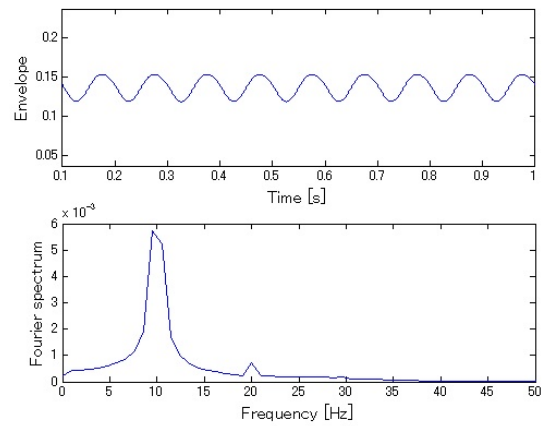

(a) Envelope of the high frequency component

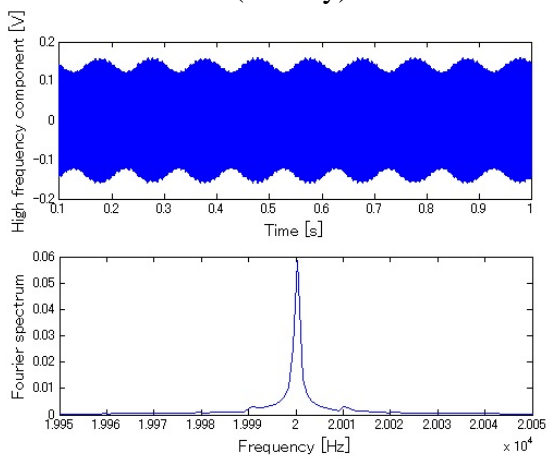

(b) 10% reduction in equivalent stiffness (damaged)

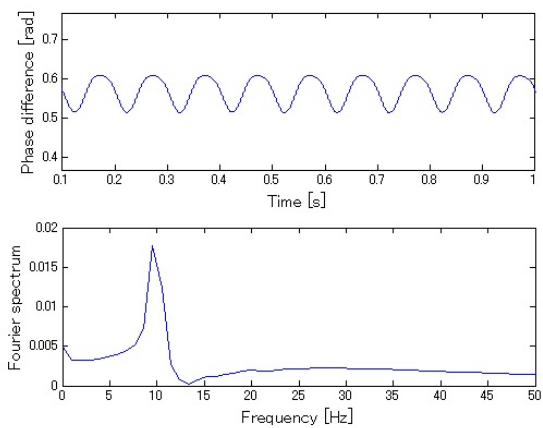

(b) Phase difference between the probe input and the high frequency component

Figure 5 High frequency component of the observed waveform at PZT 2

Figure 6 Amplitude and phase modulation in high frequency component shown in Fig.5 (b)

where B_{\max} and B_{\min} are the maximum and the minimum of the modulated amplitude.

RESULTS AND DISCUSSIONS

Amplitude and Phase Modulation of Received Probe Wave

Firstly, in order to get an understanding how the presence of the crack can affect the observed probe wave, the high frequency components extracted from the output voltage of PZT 2 with a 10 kHz~30 kHz bandpass filter are shown in Fig. 5. In comparison between the healthy specimen and the damaged specimen (10% reduction in the equivalent stiffness), significant modulation in amplitude is observed in the figure of damaged specimen. The amplitude of the high frequency 20 kHz oscillation is modulated by the low frequency 10 Hz oscillation. To see the detail of this effect, the high frequency component is demodulated by extracting its envelope using Hilbert transform, and the spectrum of the envelope is

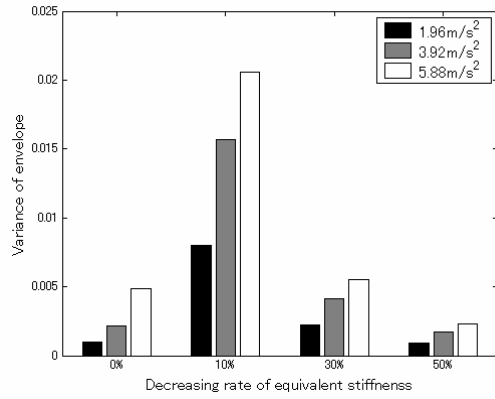

(a) Amplitude of amplitude modulation

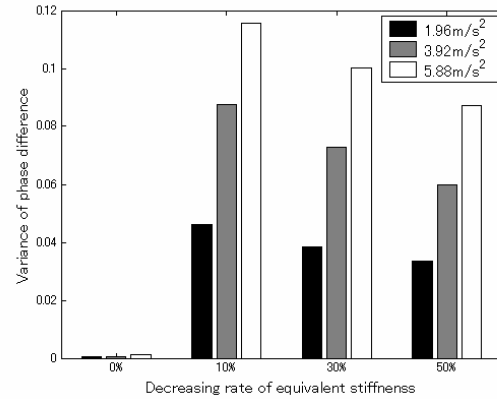

(b) Amplitude of phase modulation

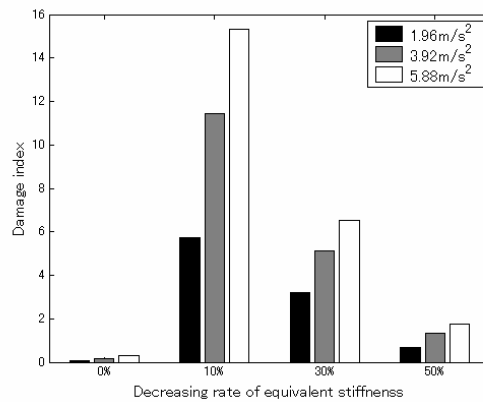

(c) Damage index defined as Eq. (2)

Figure 7 Quantitative damage indices in function of the damage extent

derived after offset correction. The envelope and its spectrum are shown in Fig.6 (a). They indicate that the oscillation of the amplitude has 10 Hz fundamental frequency.

Besides the amplitude modulation, the phase of the probe wave is also modulated. To see this, the phase difference between the observed high frequency component and the probe input is plotted in Fig. 6 (b). Again, they indicate that the phase is also modulated at 10 Hz.

Crack Development and Modulation

In order to see how the modulation quantities depend on the damage extent due to the development of the crack, the evolution of the amplitude of the amplitude-demodulated signal, amplitude of the phase-demodulated signal and the damage index defined as Eq. (2) are plotted in Fig. 7. Those values significantly increase once the specimen yields damage, but decrease as the damage progresses. The rapid increase of the modulation in the early stage of crack development implies that using those values may provide a sensitive index of early damage.

The decrease of the modulation observed in the later stage should be carefully addressed in the future study. One possible explanation for the decrease of modulation is that the stress at the crack location may have been relaxed as the progress of the reduction of the stiffness

because the displacement of the tip of the specimen has been held constant in the experiments.

CONCLUSIONS

In this paper, the applicability of the nonlinear wave modulation technique to the crack monitoring has been experimentally investigated. Experiments using a beam with low-cycle fatigue cracks have been conducted for the purpose of preliminary study, in which two PZT patches have been used as the transducer of high frequency probe wave. The collected signal at the receiver PZT has been separated into low frequency and high frequency components, the latter has been demodulated in amplitude and phase. A damage index has been defined based on the amplitude modulation and its high sensitivity to the crack progress in the early stage has been demonstrated.

ACKNOWLEDGEMENTS

The authors gratefully acknowledge the support by the Ministry of Education, Culture, Sports, Science and Technology, Grant-in-Aid for Scientific Research (B), 16560210, 2005.

REFERENCES

1. K. E.-A. Van Den Abeele, P. A. Johnson and A. Sutin, Nonlinear elasticwave spectroscopy (NEWS) techniques to discern material damage, Part I: Nonlinear wave modulation spectroscopy (NWMS), *Res Nondestr Eval*, Vol. 12, pp. 17--30, 2000.
2. A.M. Sutin and P.A. Johnson, Nonlinear elastic wave NDE II: Nonlinear wave modulation spectroscopy and nonlinear time reversed acoustics, *Review of Progress in Quantitative Nondestructive Evaluation*, AIP Conference Proceedings, Vol. 760, pp. 385--392, 2005.
3. V. Zaitsev, V. Gusev, B. Castagnede and P. Sas, Micro-damage detection using a modulation technique based on dissipative nonlinear effects, *Proceedings of Forum Acusticum Sevilla 2002*, 2002.
4. V. Zaitsev and P. Sas, Nonlinear response of a weakly damaged metal sample: a dissipative mechanism of vibro-acoustic interaction, *ournal of Vibration and Control*, Vol. 6, pp. 803--822, 2000.
5. V. V. Kazakov and P. A. Johnson, Nonlinear wave modulation imaging, *Nonlinear Acoustics at the Beginning of the 21st Century*, O.V. Rudenko and O.A. Sapozhnikov, ed., Vol. 2, pp. 763--766, 2002.
6. A. Masuda, Y. Yonemura and A. Sone, Active sensing and characterization of nonlinear damages by modulated phases and envelopes of scattered waves, *Proceedings of SPIE*, Vol. 6174, pp. 727-737, 2006.